

Installation and Servicing Instructions

Alpha Pro Tec Plus 50, 70, 90 and 115

**Wall Mounted, Fan Assisted, Gas Fired, High Efficiency
Condensing System Boilers**

For Technical help or for Service call ...
ALPHA HELPLINE Tel: 0344 871 8764
website: www.alpha-innovation.co.uk

Alpha
HEATING INNOVATION

Nepicar House, London Road,
Wrotham Heath, Sevenoaks,
Kent TN15 7RS

Pro Tec Plus 50	G.C. No. 41 532 30
Pro Tec Plus 70	G.C. No. 41 532 32
Pro Tec Plus 90	G.C. No. 41 532 34
Pro Tec Plus 115	G.C. No. 41 532 36



Set for use with Natural Gas

Leave these instructions with the User

BENCHMARK SCHEME

To comply with Building Regulations Part L1 (Part 6 in Scotland) the boiler should be installed in accordance with the manufacturer's instructions. Self-certification that the boiler has been installed to comply with Building Regulations can be demonstrated by completing and signing the Benchmark Checklist at the back of these instructions.



Code of Practice

For the installation, commissioning and servicing of domestic heating and hot water products.

Benchmark places responsibilities on both manufacturers and installers*. The purpose is to ensure that customers** are provided with the correct equipment for their needs, that it is installed, commissioned and serviced in accordance with the manufacturer's instructions by competent persons and that it meets the requirements of the appropriate Building Regulations. Installers are required to carry out work in accordance with the following:

Standards of Work

- Be competent and qualified to undertake the work required.
- Install, commission, service and use products in accordance with the manufacturer's instructions provided.
- Ensure that where there is responsibility for design work, the installation is correctly sized and fit for purpose.
- Meet the requirements of the appropriate Building Regulations. Where this involves notifiable work be a member of a Competent Persons Scheme or confirm that the customer has notified Local Authority Control (LABC), prior to work commencing.
- Complete all relevant sections of the Benchmark Checklist/Service Record when carrying out commissioning or servicing of a product or system.
- Ensure that the product or system is left in a safe condition and, where possible, in good working order.
- Highlight to the customer any remedial or improvement work identified during the course of commissioning or servicing work.
- Refer to the manufacturer's helpline where assistance is needed.
- Report product faults and concerns to the manufacturer in a timely manner.

Customer Service

- Show the customer any identity card that is relevant to the work being carried out prior to commencement or on request.
- Give a full and clear explanation/demonstration of the product or system and its operation to the customer.
- Hand over the manufacturer's instructions, including the Benchmark Checklist, to the customer on completion of an installation.
- Obtain the customer's signature on the Benchmark Checklist to confirm satisfactory demonstration and receipt of manufacturer's instructions.
- Advise the customer that regular product servicing is needed, in line with manufacturers' recommendations, to ensure that safety and efficiency is maintained.
- Respond promptly to calls from a customer following completion of their work, providing advice and assistance by phone and, if necessary, visiting the customer.
- Rectify any installation problems at no cost to the customer during the installer's guarantee period.

* The use of the word "installer" is not limited to installation itself and covers those carrying out installation, commissioning and/or servicing of heating and hot water products, or the use of supporting products (such as water treatment or test equipment).

** Customer includes householders, landlords and tenants.

Benchmark Commissioning and Servicing Section

It is a requirement that the boiler is installed and commissioned to the manufacturers instructions and the data fields on the commissioning checklist completed in full.

To instigate the boiler guarantee the boiler needs to be registered with the manufacturer within one month of the installation.

To maintain the boiler guarantee it is essential that the boiler is serviced annually by a Gas Safe registered engineer who has been trained on the boiler installed. The service details should be recorded on the Benchmark Service Interval Record and left with the householder.

www.centralheating.co.uk



Useful contact details: Gas Safe Register - 0800 408 5577 - www.gassaferegister.co.uk

Alpha Heating Innovation: General Sales Enquiries - 0344 871 8760
Technical Helpline - 0344 871 8764

CONTENTS

1	Introduction.....	3	9	Fault finding	35
2	Safety symbols	4	10	Programming the boiler PCB.....	37
3	General data.....	5	11	Performance data	39
4	General boiler information	12	12	Cascade system installation.....	41
5	Installation	17	13	Short parts list	42
6	Commissioning and using the boiler	24	14	Energy classification.....	43
7	Routine servicing.....	29		Benchmark Checklist.....	51
8	Wiring diagram	34		Service record	52

1 INTRODUCTION

The Alpha Pro Tec Plus range are wall mounted high efficiency condensing, fan assisted system boilers. The burner is lit electronically and the heat output is controlled by a modulating fan and gas valve.

These are system boilers providing heating only for sealed central heating systems. However, they may be used with an open central heating system if required - refer to Section 3.8.

The boilers are supplied with type B23 flue configuration (open chamber and forced draught) but can be changed to type C (room sealed) by using a kit.

The boilers are fitted with a low energy modulating pump, 4 bar safety valve and pressure gauge fully assembled and tested. They are designed for use with a fully pumped, sealed and pressurised central heating system. If used with an open system refer to Section 4.8.

The boilers can be supplied for use with Natural gas or Propane Gas (LPG).

Note: There are a number of additional controls and accessories available for use with the boilers to enable cascade and zone installations to be used - See Section 12. Further information is available from Alpha Therm Ltd.

IMPORTANT

It is the law that all gas appliances are installed by a competent person, ie Gas Safe registered personnel, in accordance with the following recommendations:-

Current Gas Safety (Installation and Use) Regulations

All current Building Regulations issued by the Department of the Environment, i.e. Approved Document L2B.

Building Standards (Scotland) (Consolidation) Regulations issued by the Scottish Development Department

UK Water Regulations/Byelaws (Scotland)

Health & Safety Document No. 635 (The Electricity At Work Regulations 1989)

The installation should also be in accordance with the following British Standard Codes of Practice:-

BS 5440-1: 2008.....Flueing and Ventilation Requirements

BS 5440-2: 2009.....Installation and Maintenance of Flues and Ventilation

BS 5546: 2010.....Specification for Water Heating Appliances

BS 6644: 2011.....Specification for Installation gas fired boilers 70 kW – 1.8 MW

BS 6798: 2009.....Specification for Installation gas fired boilers up to 70 kW

BS 6891: 2005 + A2: 2008.....Installation of low pressure Gas Pipework

IGEM/UP/2

IGEM/UP/4

IGE/UP/10

IGEM/UP/16

IGE/UP/1, 1A and 1B.....Strength Testing and tightness testing Natural Gas Installations

Reference should also be made to any other standards and requirements relating to the installation depending on the location and use.

Reference should be made to DEFRA document 'Guide to condensing boiler installation assessment procedures for dwellings'.

If installation is in a timber framed building, refer to the Institute of Gas Engineers document IGE/UP/7.

This appliance meets the requirements of IPX5D, ie degree of protection against moisture.

This appliance contains no asbestos and no substances have been used in the construction process that contravene the COSHH Regulations (Control of Substances Hazardous to Health).

Failure to install this appliance correctly could lead to prosecution. It is in your own interest and that of safety to ensure that the law is complied with.

Manufacturer's instructions must **NOT** be taken in anyway as over-riding statutory obligations.

Notes: 1. Ensure that the Benchmark Checklist has been completed after the boiler has been installed and commissioned.

2. It is the law that all domestic boiler installations are registered by the installer through the Gas Safe Notification Scheme.

Propane Gas (LPG) - In addition to the regulations and requirements stated, the boiler **must be** installed in accordance with BS 5482:1 - The Installation of Propane Burning Appliances in Permanent Dwellings.



2 SAFETY SYMBOLS



GENERIC HAZARD

Strictly follow all of the indications next to the symbol. Failure to follow the indications can generate hazard situations resulting in possible harm to the health of the operator and user in general.



ELECTRICAL HAZARD

Strictly follow all of the indications next to the symbol. The symbol indicates the appliance's electrical components or, in this manual, identifies actions that can cause an electrical hazard.



MOVING PARTS

The symbol indicates the appliance's moving components that can cause hazards..



HOT SURFACES

The symbol indicates the appliance's very hot components that can cause burns.



SHARP SURFACES

The symbol indicates the appliance's components or parts that can cause cuts if touched.



EARTH TERMINAL CONNECTION

The symbol identifies the appliance's earth terminal connection point.



READ AND UNDERSTAND THE INSTRUCTIONS

Read and understand the appliance's instructions before performing any operation, carefully following the indications provided.



INFORMATION

Indicates useful tips or additional information.



RECOVERABLE OR RECYCLABLE MATERIAL



The user must not dispose of the appliance at the end of its service life as municipal waste, but send it to appropriate collection centres.

PERSONAL PROTECTIVE EQUIPMENT



SAFETY GLOVES



SAFETY GOGGLES



SAFETY FOOTWEAR

3 GENERAL DATA

3.1 TECHNICAL DATA



Model	Pro Tec Plus	50	70	90	115
Heat output condensing (50/30°C)	kW	54.8	74.5	98.8	121.7
Heat output non condensing (80/60°C)	kW	49.9	68.0	90.0	111.0
Heat output minimum	kW	5.0	7.2	9.4	11.0
NOx	Class	6	6	6	6
Maximum CO/CO ₂	Ratio	0.003	0.003	0.003	0.003
Maximum CO	ppm	200	300	250	300
SAP/SEDBUK seasonality efficiency 2005	%	90.0	90.0	90.1	90.0
SAP/SEDBUK seasonality efficiency 2009	%	88.5	88.6	88.7	88.5
Efficiency at maximum output 60°C/80°C	%	97.3	97.3	97.5	97.3
Efficiency at maximum output 30°C/50°C	%	106.8	106.6	107.0	106.7
Efficiency at part load 30°C/50°C	%	107.0	107.2	107.8	107.6
Efficiency at part load 30°C/40°C	%	107.0	107.2	107.8	107.6
Maximum system temperature	°C	85	85	85	85
Adjustable system temperature	°C	20 - 85	20 - 85	20 - 85	20 - 85
Maximum primary system pressure	bar	3.5	3.5	3.5	3.5
Minimum primary system pressure	bar	0.5	0.5	0.5	0.5
Recommended system pressure - Cold	bar	1	1	1	1
System safety valve setting	bar	4	4	4	4
Electrical power supply	V ~ 50 Hz	230	230	230	230
Electrical power consumption - Maximum	Watts	155	195	345	385
Electrical power consumption - Standby	Watts	6	5	5	5
EEl value - Energy efficiency index		≤ 0.23 Part 3			

3.2 PHYSICAL DATA



Model	Pro Tec Plus	50	70	90	115
Boiler flow and return connections	BSP	1½"	1½"	1½"	1½"
Pressure relief valve connection	BSP	¾"	¾"	¾"	¾"
Gas connection	BSP	28 mm	28 mm	28 mm	28 mm
Boiler dimensions	Height	mm	843	1038	1038
	Width	mm	442	600	600
	Depth	mm	457	502	632
Clearances for servicing	Bottom	mm	400	400	400
	Top (horizontal flue)	mm	300	300	300
	Top (vertical flue)	mm	150	150	150
	Sides	mm	10	10	10
	Front	mm	500	500	500
Boiler dry lift weight	kg	51	81	96	103
Boiler operating weight (full of water) approx.	kg	54	85	106	114
Water content	litre	3	4	10	11

3.3 COMBUSTION DATA



Natural Gas G20 (Cat I2H 2H)

Model	Pro Tec Plus	50	70	90	115
Heat input (gross)	kW	56.9	77.6	102.5	126.7
Heat input (net)	kW	51.3	69.9	92.3	114.1
Gas burner injector diameter	mm	8.4	12.7	11.3	16.5
Gas supply pressure	mbar	20	20	20	20
Gas rate at maximum output	m ³ /h	5.43	7.4	9.77	12.07
Flue mass flow rate at maximum output	kg/h	81	106	146	174
Flue mass flow rate at minimum output	kg/h	9	13	16	19
Flue temperature (nominal)	°C	52	58	53	56
CO ₂ at maximum output (factory set)	%	9.4	9.90	9.4	9.8
CO ₂ at minimum output (factory set)	%	9.1	8.95	9.0	9.0
CO (nominal) at 0% O ₂	ppm	157	256	210	257
CO weight (nominal)	mg/kWh	15	28	12	18
Dry NOX weighted	mg/kWh	38	25	20	31

Propane G31 (Cat I3P 3P)

Model	Pro Tec Plus	50	70	90	115
Heat input (gross)	kW	55.8	76.0	100.3	124.0
Heat input (net)	kW	51.3	69.9	92.3	114.1
Gas burner injector diameter	mm	6.5	8.5	8.4	9.7
Gas supply pressure	mbar	37	37	37	37
Gas rate at maximum output	l/h	7.7	10.4	13.8	17.0
Flue mass flow rate at maximum output	kg/h	82	112	148	183
Flue mass flow rate at minimum output	kg/h	9	13	16	19
Flue temperature (nominal)	°C	53	57	54	56
CO ₂ at maximum output (factory set)	%	10.6	9.8	10.6	10.6
CO ₂ at minimum output (factory set)	%	10.1	10.0	10.1	10.0
CO (nominal) at 0% O ₂	ppm	184	134	230	220
CO weight (nominal)	mg/kWh	15	28	12	18
Dry NOX weighted	mg/kWh	38	25	20	31

3.4 FLUE DATA



Model	Pro Tec Plus	50	70	90	15
* Max. flue length 80/125 concentric (room sealed)	m	14.5	11	8	5
* Max. flue length 80 single pipe (B23 open flue)	m	30	28	14	8.5
Flue system (optional)	Concentric flue	mm	80/125	80/125	80/125
	Hole in wall required	mm	127	127	127
Flue system (as supplied)	Open flue	mm	80	80	80
	Hole in wall required	mm	100	100	100

* Maximum Flue Lengths (includes first bend onto boiler flue connection for horizontal installations)

Open flue - Maximum horizontal or vertical flue with single 80 mm dia. given in table on previous page

90° bend is equivalent to 2.1 m of flue length

45° bend is equivalent to 1.3 m of flue length

Vertical terminal is equivalent to 2 m of flue length

Concentric flue - Maximum horizontal flue or vertical flue given in table on previous page

90° bend is equivalent to 1.9 m of flue length

45° bend is equivalent to 1.4 m of flue length

Vertical terminal is equivalent to 2 m of flue length

- Notes:**
1. Ensure all flues slope downwards towards the boiler by a minimum of 25 to 30 mm per metre of flue.
 2. It is recommended that horizontal and vertical flue assemblies should be supported approximately every 1.5 m with access provided to the joints.
 3. These dimensions only apply for flue parts supplied by Alpha.

Cascade flue options are also available, please contact Alpha for further details.

3.5 PUMP

Both pump with UPM3 electronics and pump with LED and UPM3 W3 (Wave 3) electronics

The boiler is equipped with a low power consumption pump.

The pump speed is controlled automatically in order to give a proportional pump head.

Pump release - After a prolonged period of inactivity, the pump might stick, and it may be necessary to turn the motor shaft using a screwdriver. Take great care during this operation to avoid damage to the motor.

For systems without a low loss header or barrier heat exchanger, a system by-pass **must be** fitted.

For larger systems an additional external pump can be fitted and controlled by the boiler using a relay switch. See Fig. 3.5.

Pump with LED and UPM3 W3 (Wave 3) electronics ONLY

When the pump is running, the LED lights with a steady green light.

When the pump switches on, the green LED flashes at a higher intensity and then returns to normal intensity with a steady green light.

If the pump detects an alarm, the LED switches from green to red which can mean one of the following:

- a - Low supply voltage.
- b - Seized rotor.
- c - Electrical fault.

To see in detail the meaning of the red LED, please refer to the end of Section 9.

The LED in addition to being green or red, can also remain off. It is normal for the LED to be off when the pump is not running whereas with the pump running the LED must be lit, if it is not it means there is a fault.



Pro Tec Plus 50 pump (15 - 65)

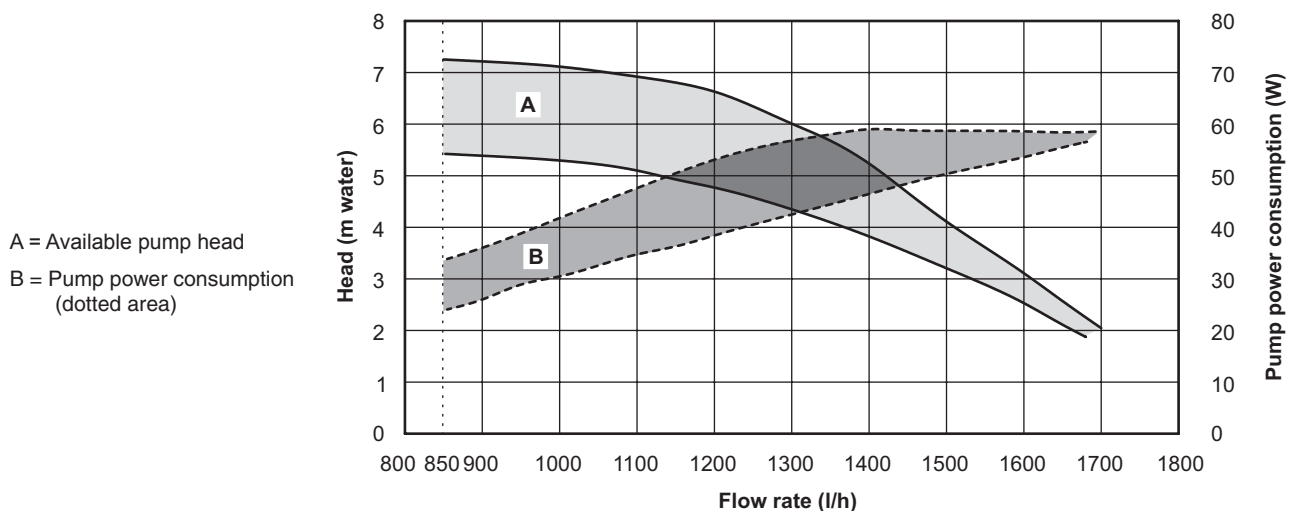

Fig. 3.1

Pro Tec Plus 70 pump (25 - 85)

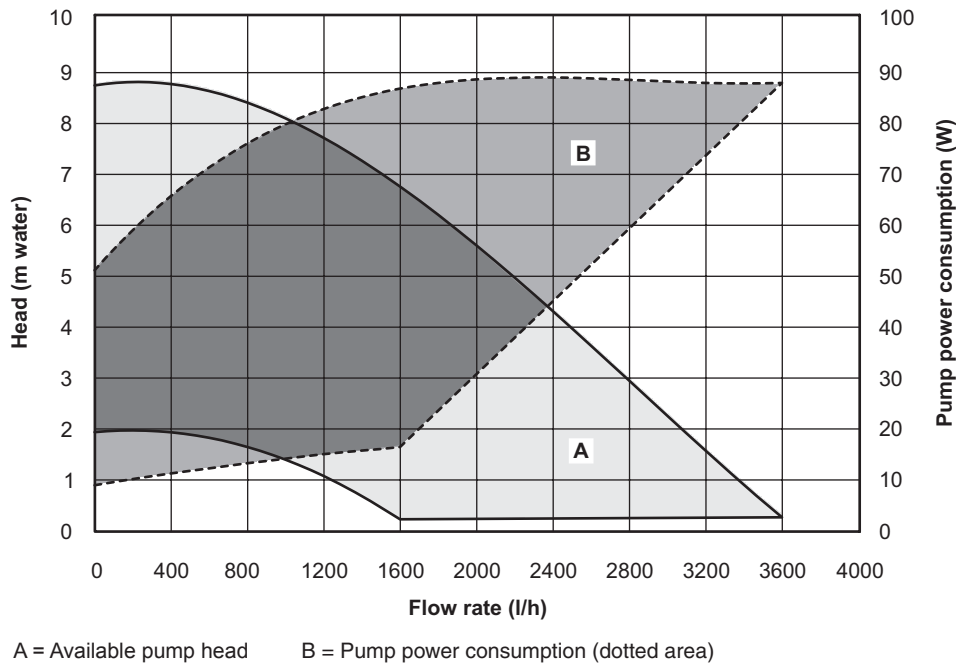

Fig. 3.2

Pro Tec Plus 90 pump (25 - 125)

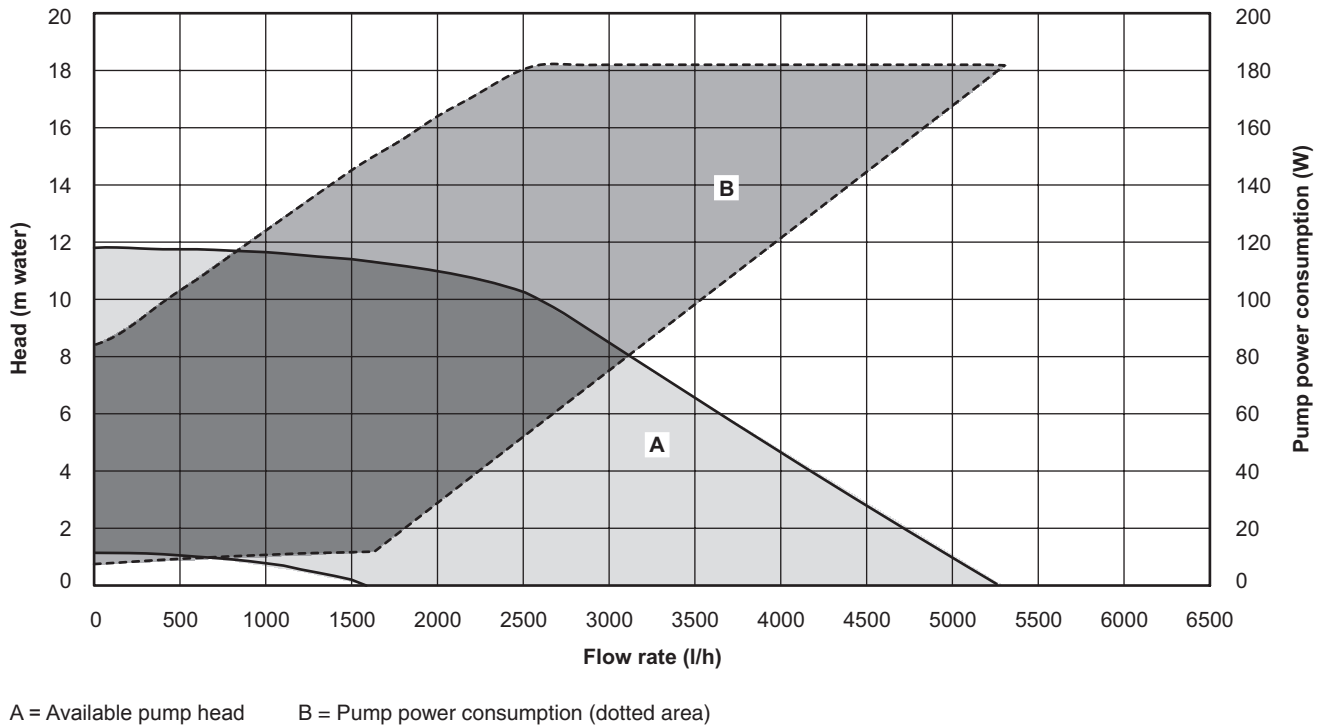

Fig. 3.3

Pro Tec Plus 115 pump (25 - 125)

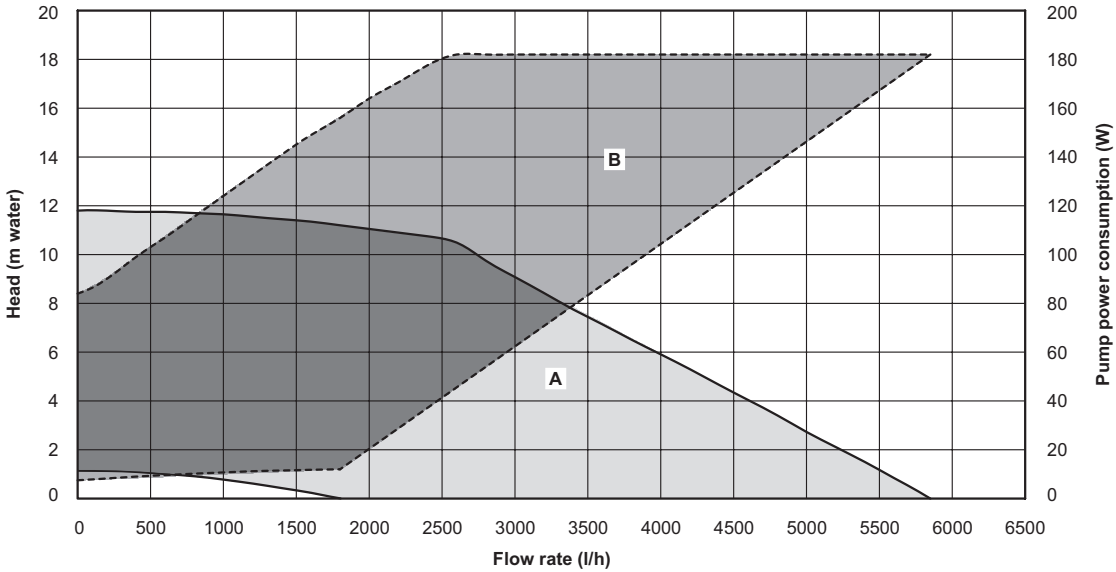

Fig. 3.4

A = Available pump head B = Pump power consumption (dotted area)

3.6 ELECTRICAL CONNECTIONS

Note: This Appliance Must Be Earthed

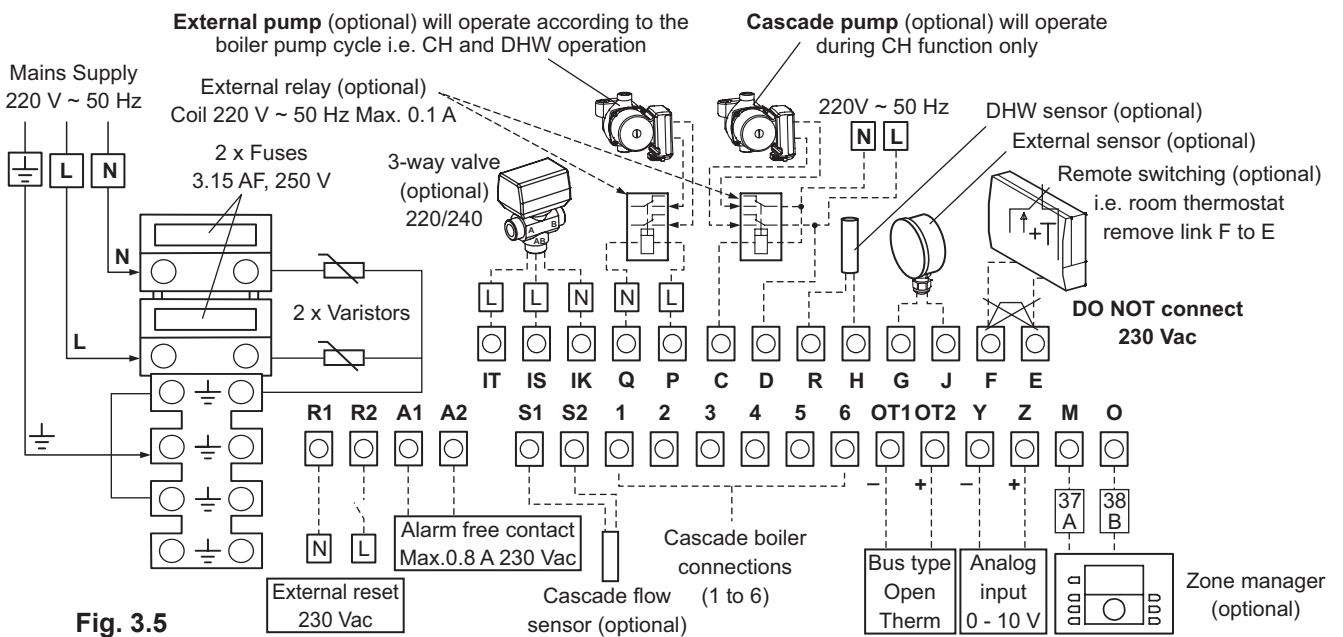

Fig. 3.5

3.7 BASIC CASCADE FUNCTION

It is possible to control two boilers together in cascade without a cascade controller using the System Flow Probe Kit 3.024245 connected to the common flow circuit and linking the bus connections in the boiler as shown in Fig. 3.6. With this configuration the master boiler can be controlled normally with external controls connected and the two boilers will function in sequence as a cascade. Contact Alpha for further details on this function.

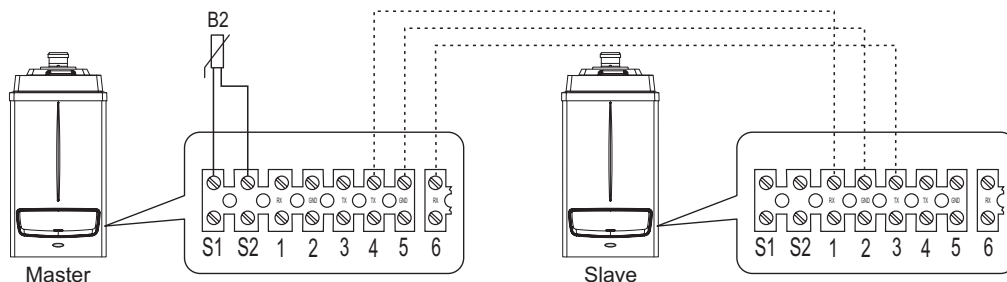
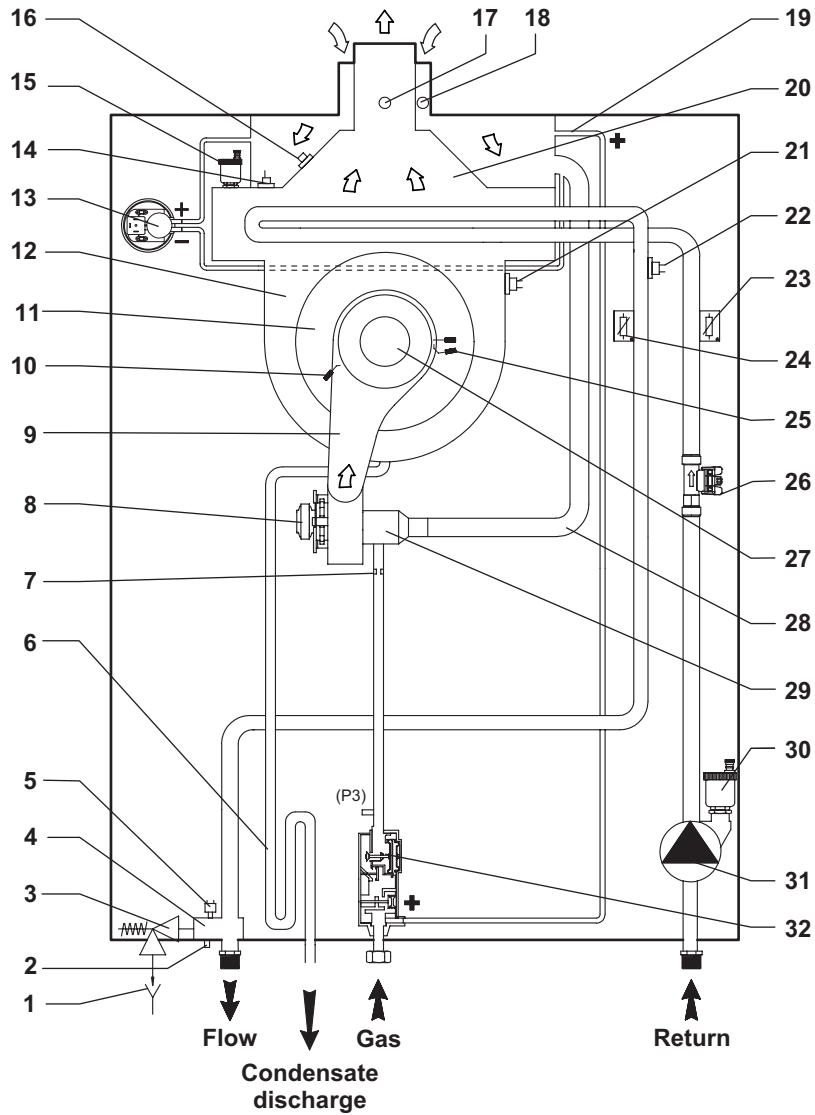

Fig. 3.6

3.8 BOILER SCHEMATIC

Pro Tec Plus 50



- | | | | |
|----|-----------------------------------|----|------------------------------------|
| 1 | Tundish | 17 | Flue sampling point |
| 2 | Drain point | 18 | Air sampling point |
| 3 | Safety valve (4 bar) | 19 | Venturi positive point (P2) |
| 4 | Flow manifold | 20 | Flue hood |
| 5 | Pressure switch | 21 | Overheat thermostat (manual reset) |
| 6 | Condensate trap | 22 | Overheat thermostat |
| 7 | Injector | 23 | Primary return temperature sensor |
| 8 | Fan | 24 | Primary flow temperature sensor |
| 9 | Manifold cover | 25 | ignition electrode |
| 10 | Flame sensing electrode | 26 | Primary flow switch |
| 11 | Combustion chamber cover | 27 | Burner |
| 12 | Heat exchanger | 28 | Air inlet pipe |
| 13 | Air pressure switch | 29 | Venturi |
| 14 | Flue sensor | 30 | Automatic air vent |
| 15 | Heat exchanger automatic air vent | 31 | Pump |
| 16 | Thermofuse | 32 | Gas valve |

Fig. 3.7

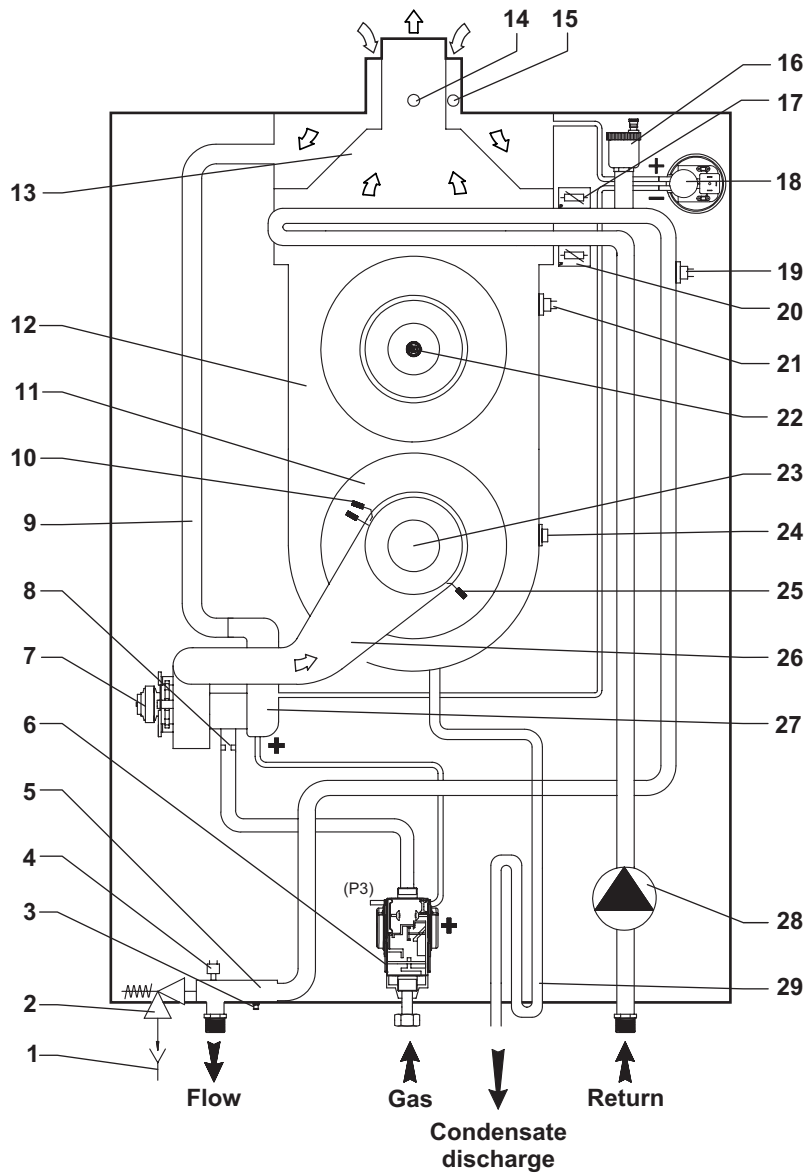

- | | | | |
|----|--------------------------|----|------------------------------------|
| 1 | Tundish | 16 | Heat exchanger automatic air vent |
| 2 | Safety valve (4 bar) | 17 | Primary flow temperature sensor |
| 3 | Drain point | 18 | Air pressure switch |
| 4 | Primary pressure switch | 19 | Overheat thermostat |
| 5 | Flow manifold | 20 | Primary return temperature sensor |
| 6 | Gas valve | 21 | Overheat thermostat (manual reset) |
| 7 | Fan | 22 | Flue sensor |
| 8 | Injector | 23 | Burner |
| 9 | Air inlet pipe | 24 | Thermofuse |
| 10 | Ignition electrode | 25 | Flame sensing electrode |
| 11 | Combustion chamber cover | 26 | Manifold cover |
| 12 | Heat exchanger | 27 | Venturi |
| 13 | Flue hood | 28 | Pump |
| 14 | Flue sampling point | 29 | Condensate trap |
| 15 | Air sampling point | | |

Fig. 3.8

4 GENERAL BOILER INFORMATION

4.1 GAS SUPPLY

Natural Gas:

The meter and supply pipes must be capable of delivering the required quantity of gas in addition to the demand from any other appliances.

The boiler requires at least a 28 mm gas supply pipe and ensure the inlet supply pressure is at least 20 mbar (Natural Gas)

The complete installation, including the meter, must be tested for gas tightness and purged as described in BS 6891 and IGE/UP/1, IGE/UP/1A or IGE/UP1B.

Propane Gas (LPG):

The local Propane Gas supplier should be consulted, at the installation planning stage, in order to establish the availability of an adequate supply of gas, 37 mbar for Propane Gas (LPG).



4.2 ELECTRICAL SUPPLY

The boiler requires a 220/240 V ~ 50 Hz permanent mains supply, fused at 3 A

Note: The boiler must be earthed.

There must only be one common isolator, providing complete electrical isolation, for the boiler and any external controls.

This boiler has been fitted with a supply cable, however, if it is necessary to fit a cable use PVC insulated cable not less than 0.75 mm² (24 x 0.2 mm). The boiler should be connected to a fused three pin plug and unswitched shuttered socket outlet, or a fused double pole switch with a contact separation of at least 3 mm in both poles.

Wiring external to the boiler must be in accordance with the current IEE Wiring Regulations (BS 7671).



4.3 AIR SUPPLY

Open flued (Type B23 flue)

Alpha Pro Tec Plus boilers leave the factory with 'B23' type configuration (open chamber and forced draught - single flue pipe) and receive the air for combustion from openings in the rear of the boiler, therefore air supply for combustion and ventilation must be provided in accordance with BS 5440:2 (for domestic installations with a net input less than 70 kW) or BS 6644 (for commercial installations with a net input over 70 Kw).

Room sealed (Type C flue)

If the boilers are converted to a 'C' type configuration (sealed chamber and forced draught - concentric flue pipe) as described in Section 3.4 only air for ventilation is required.

1. **If the boiler is installed in a room** - No air vents are required in the room in which the boiler is installed.
2. **If the boiler is installed in a cupboard or compartment** - Permanent air vents for ventilation are required in the cupboard or compartment, one at high level and one at low level, either direct to the outside air or to a room. Both the high and low level air vents must communicate with the same room or must be on the same wall to outside air. Both the high and low level vent must each have a free area as per BS 5440:2 or BS 6644.

The minimum clearances for servicing must always be maintained.



4.4 FLUE SYSTEM

The flue system must be installed in accordance with BS 5440:1 or BS 6644.

For horizontal flues ensure the flue assembly slopes downwards towards the boiler by a minimum of 25 - 30 mm per metre of flue.

It is recommended that horizontal and vertical flue assemblies should be supported at least every 1.5 m with access provided to the joints.

Alpha Pro Tec Plus boilers leave the factory with 'B23' type flue configuration (open chamber and forced draught - single flue pipe). To change the configuration to 'C' type (sealed chamber and forced draught - concentric flue pipe), remove the 80 mm dia. adapter, the bracket and gasket from the top of the boiler and fit the concentric flue adaptor, see Sections 5.5 and 5.6.

- Note:**
1. Under no circumstances must the flue length (including allowances for extra bends) exceed the maximum flue lengths stated for each type of flue.
 2. Failure to use the correct Alpha flue components with the boiler will invalidate the boilers CE approval, guarantee and may be unsafe.

Seals for flue elements - If lubrication of components (already performed by the manufacturer) is not sufficient, remove the residual lubricant using a dry cloth, then to ease fitting apply a small amount of common or industrial talc to the seal.

Ensure that the seals are correctly located in the elbows and extensions when assembling the flue.

Note: Do not use silicone or other oil based lubricants on the flue seals.

All joints between flue sections should be connected using the clamps provided. It is not required to add additional screws through the clamps and into the flue sections.

When fitting multiple boilers on a combined flue system, all boilers must have a non-return valve fitted.



Flue components are available as follows:-

Open flue - 80 mm dia. single pipe

- 6.2004200.....Horizontal terminal kit 80 mm dia. (includes 1 metre straight terminal section, one 90° bend and two collars)
- 6.2004220.....Vertical terminal kit 80 mm dia.
- 6.2004210.....Extension pipe 1 metre x 80 mm dia.
- 6.2004290.....90° bend 80 mm dia.
- 6.2004245.....45° bend 80 mm dia.
- 6.2004260.....80 mm flue support bracket (5 pk)
- 6.1000380.....Pitched roof flashing (universal)
- 6.1000390.....Flat roof flashing (universal)

Concentric flue - 80/125 mm dia.

- 6.2003205.....Horizontal terminal kit 80/125 mm dia. (includes 1 metre straight terminal section, one 90° bend, two collars and adaptor with square gasket)
- 6.2003225.....Vertical terminal kit 80/125 mm dia. (includes adaptor with square gasket)
- 6.2003210.....Extension kit 1 metre x 80/125 mm dia.
- 6.2003290.....90° bend 80/125 mm dia.
- 6.2003245.....45° bend 80/125 mm dia.
- 6.1000380.....Pitched roof flashing (universal)
- 6.1000390.....Flat roof flashing (universal)

Cascade flue options are also available for multiple boilers.

4.4.1 Horizontal Flue Options

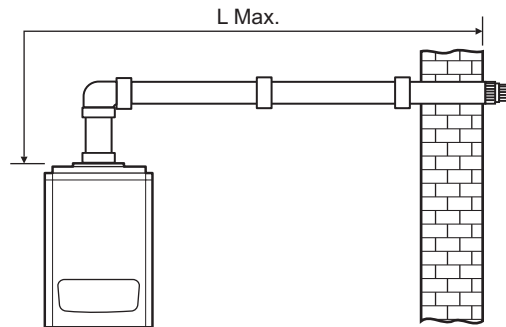
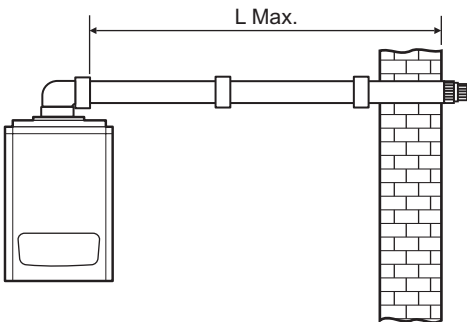

Open flue: 80 mm dia. single pipe
 90° bend is equivalent to 2.1 m of flue length
 45° bend is equivalent to 1.3 m of flue length

Concentric flue: 80/125 mm dia.
 90° bend is equivalent to 1.9 m of flue length
 45° bend is equivalent to 1.4 m of flue length

	L Max.			
	50	70	90	115
Pro Tec Plus model	50	70	90	115
80/125 mm Concentric flue	14.5 m	11 m	8 m	5 m
80 mm Open flue	30 m	28 m	14 m	8.5 m

Fig. 4.1

4.4.2 Vertical Flue Options

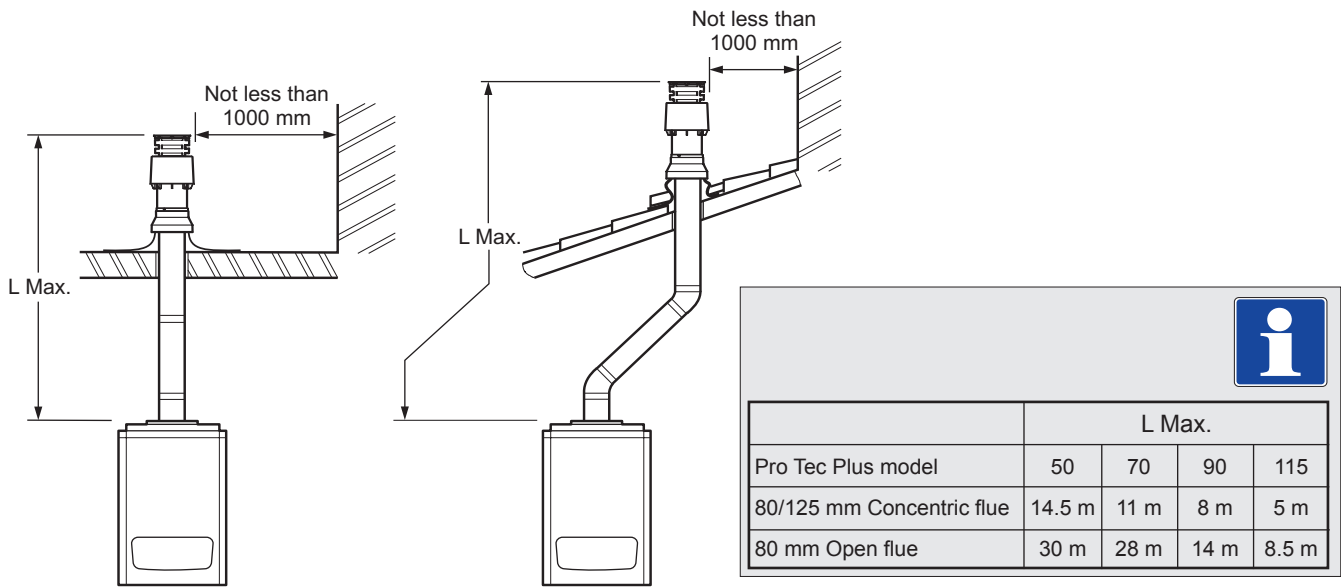

Fig. 4.2

4.5 FLUE TERMINATION

The Alpha Pro Tec Plus range of boilers can be individually flued using either 80 mm open flue configuration or 80/125 mm concentric flue.

Multiple boilers can be individually flued or cascade flue kits are also available in 150 mm or 200 mm.

When installing these boilers careful planning and consideration for the flue system must be undertaken. All flue systems must conform to the relevant standards depending on the boiler size and configuration.

Refer to BS 6644, BS 5440 or IGE/UP/10 for the correct flue location requirements.

4.6 BOILER LOCATION

The boiler is not suitable for external installation unless it is installed within a purpose designed weatherproof building.



The boiler must be installed on a flat vertical wall which is capable of supporting the weight of the boiler. The boiler can be fitted to or adjacent to a wall comprising of a combustible material without the need for a special thermal insulation barrier.

If the boiler is to be fitted in a timber framed building, it should be fitted in accordance with the Institute of Gas Engineers 'Guide for Gas Installations in Timber Frame Housing', reference IGE/UP/7.

The boiler may be installed in any room or internal space, although particular attention is drawn to the requirements of the current IEE Wiring (BS 7671) Regulations, and in Scotland, the electrical provisions of the Building Regulations applicable in Scotland, with respect to the installation of the boiler in a room or internal space containing a bath or shower. Where a room-sealed boiler is installed in a room containing a bath or shower, it must not be possible for a person using the bath or shower to touch any electrical switch or boiler control utilising mains electricity.

The boiler may be installed in a cupboard or compartment, provided it is correctly designed for that purpose, i.e. complies with the Building Regulations and the requirements of BS 6798 and BS 6644.

Propane Gas (LPG): Installation pipes, cylinders and pressure regulators should be fitted in accordance with BS 5482:1. Bulk tank installation must comply with the requirements of the Home Office code of practice for the storage of liquefied petroleum gas at fixed installations. The boiler **must not** be installed in a room or internal space below ground level, e.g. in a basement or cellar, except where at least one side is open to ground level.

4.7 FROST PROTECTION

The boiler is fitted with a frost thermostat that activates the pump and burner when the system water temperature in the boiler falls below 6°C.

The electrical supply to the boiler must be left on for the thermostat to operate and the selector switch must be set to ON .

4.8 CENTRAL HEATING SYSTEM - Fig. 4.3

The boiler is designed for use in a sealed central heating system in accordance with the requirements of BS 5449 and BS 6798.

The system should be designed to operate with flow temperatures of up to 85°C. When designing the system, the pump head, expansion vessel size, mean radiator temperature, etc. must all be taken into account. Refer to the pump performance graph Section 3.5 for guidelines.

However, if the boiler is to be used with an open central heating system refer to Fig. 4.3 and use a barrier heat exchanger (i.e. separates the boiler primary circuit from the open heating circuit). This will also ensure the boiler heat exchanger is protected from an old/dirty system.

Sealed system volume - An expansion vessel **is not** incorporated into the boiler. An expansion vessel **must be** fitted in the position shown in Fig. 4.3. To check correct operation of the expansion vessel the system pressure should not be more than 3.5 bar when the system is at maximum operating temperature (for further guidance refer to BS 7074:1), For example an 8 litre expansion vessel is suitable for a sealed system of 80 litres.

Expansion vessels should be set to 1 bar before the system is filled.

The boiler is supplied with the following components built in:-

Pressure relief valve - complying with BS 6759 and set to operate at 4 bar. The discharge pipe must be routed clear of the boiler and terminated in such a manner that it can be seen, but cannot cause injury to persons or property.

Pressure gauge - To indicate the system pressure to be maintained.

By-pass - The boiler has no built-in by-pass, therefore a by-pass is required for the system.

Installation on a low temperature heating system.

The boiler can directly feed a low temperature system, varying the maximum delivery temperature of the boiler and setting a value of between 20 and 85°C. To vary the boiler maximum delivery temperature, modify the boiler maximum delivery temperature of parameter No. 02 as described in Section 10.

In this mode it is advisable to include a safety limit thermostat set at 55°C in series with the boiler controls. The thermostat must be positioned in the system flow pipe at more than 2 metres from the boiler.

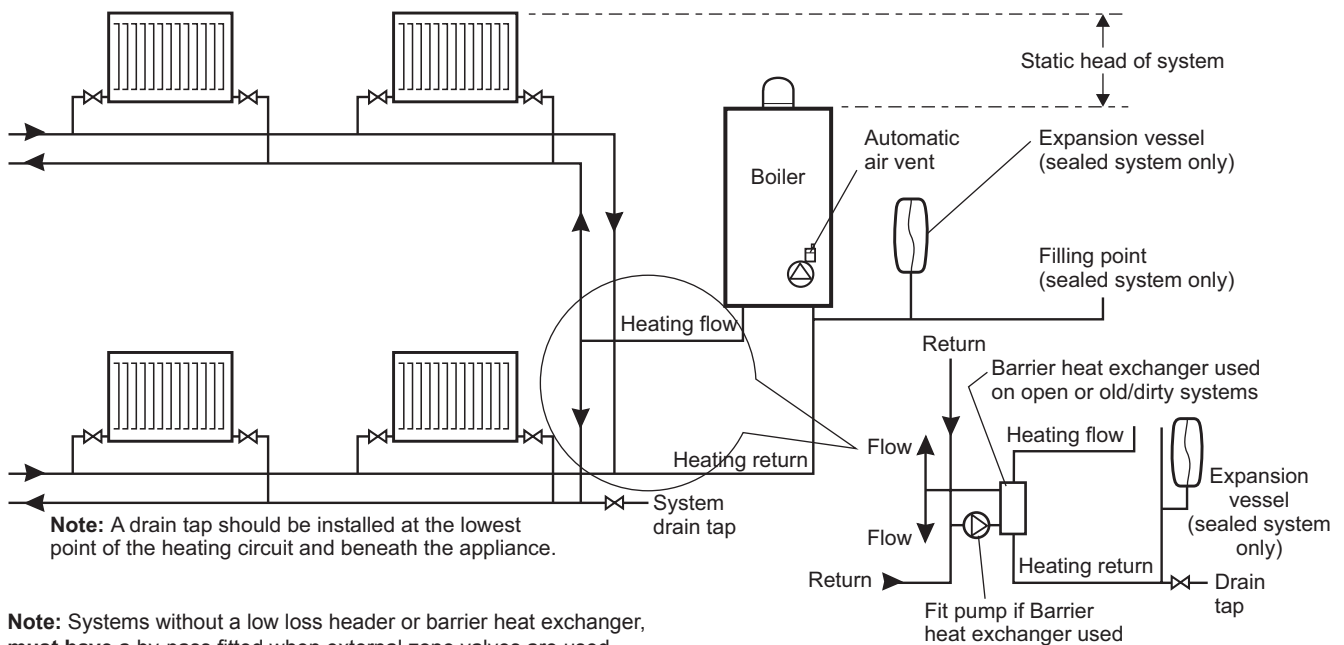

Fig. 4.3

4.9 FILLING THE SEALED CENTRAL HEATING SYSTEM

The system design pressure (cold) should be set to 1.0 bar. This pressure is equivalent to a static head (see Fig. 4.3) of 10.2 metres of water.

Provision should be made to replace water lost from the system. This can be by manual or automatic means.

Filling of the system must be carried out in a manner approved by the local Water Undertaking. Drain taps (to BS 2879) must be used to allow the system to be completely drained.

4.10 FLUSHING THE HEATING SYSTEM

It is essential that the central heating system is thoroughly cleaned and flushed before fitting an Alpha Pro Tec Plus boiler. Failure to do so will invalidate the warranty. If this is difficult because the system is old/dirty refer to Section 4.8, Fig. 4.3 gives consideration to using a barrier heat exchanger.

The primary condensing heat exchanger is constructed in stainless steel and therefore is compatible with most materials used in a heating system.

Where possible, the heating system should be cleaned before installing the boiler. A proprietary cleaner should be used following the product manufacturers' instructions. After installation the system should then be filled and flushed before final filling. A corrosion inhibitor approved by Alpha must be added to ensure that the heating system operates effectively and efficiently, it is important to maintain the correct level of corrosion inhibition at all times.

The corrosion inhibitor should be checked annually at the time of the boiler service, and topped up if necessary. A further dose of corrosion inhibitor should be added to the system every five years.

It is important to ensure that the correct level of inhibitor has been added, and that any cleaner residues have been adequately removed to maintain the operation of the boiler and heating system. Failure to correctly clean and treat the system will invalidate the boiler warranty.

If it is not possible to clean the system before fitting the new boiler, the system should be cleaned using a proprietary cleaner and a magnetic filter connected in the return before the boiler as this is the most effective method of ensuring that any magnetite and rust particles are prevented from entering and damaging the boiler.

Once the system condition has been restored, an effective magnetic filter and strainer should be fitted permanently to the system as a method of collecting any magnetite and rust from the system during operation.

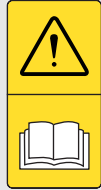

4.11 DISPOSAL OF CONDENSATE

Provision must be made for the safe disposal of condensate produced by Alpha Pro Tec Plus boilers and reference should be made to BS 6798: 2000 for the requirements on the disposal of condensate.

The boilers incorporate a condensate trap which has a seal greater than 75 mm, therefore no additional trap is required.

The condensate should ideally be discharged internally into an internal waste pipe or soil pipe to avoid the possible risk of freezing. The pipework must be in at least 22 mm pipe (non metallic).

External pipe runs should be avoided, but if it is necessary, the pipework should be at least 32 mm and protected from the risk of freezing with waterproof insulation and the length should be kept to a maximum of 3 m. Termination should be into an external gully or soakaway as shown in Fig. 4.4.

Note: All pipework must have a continuous fall (see Fig. 4.4) from the boiler and must be of an acid resistant material such as plastic waste pipe, (copper or steel is not suitable).

It should be noted that the connection of a condensate pipe to a drain may be subject to local building control requirements. If the condensate is connected to a gutter or drain down pipe where there is a risk of water blocking and rising back towards the boiler, a suitable air gap / tundish must be fitted to the condensate pipe.

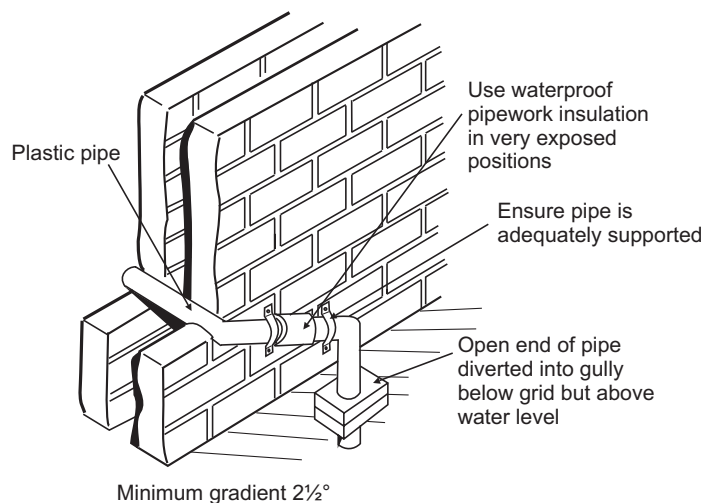
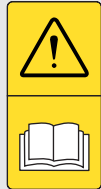

Fig. 4.4 - External gully

5 INSTALLATION

5.1 UNPACKING

- The basic boiler is supplied in a single box, containing the following:-
 Pro Tec Plus boiler
 Mounting hooks and wall plugs with coach screws
 Tundish for pressure relief valve outlet
 Condensate discharge pipe
 Gas service cock and 28 mm connection tail with washer
 Literature pack and Wall template
 Other parts of the flue system are supplied in separate packs as ordered.
- Unpack boiler and remove the loose items.



5.2 DIMENSIONS and CONNECTIONS

5.2.1 Pro Tec Plus 50

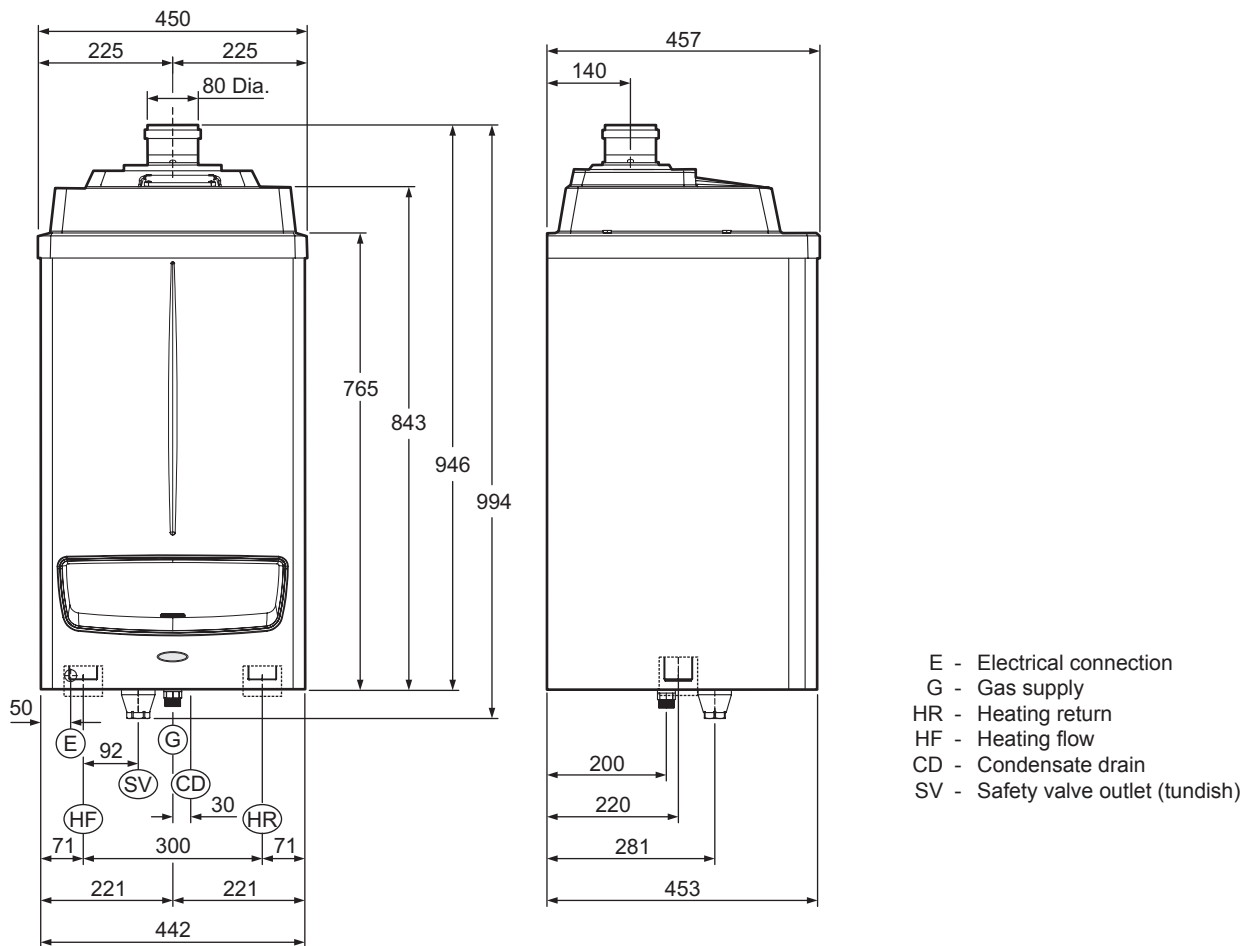

Fig. 5.1

5.2.2 Pro Tec Plus 70, 90, 115

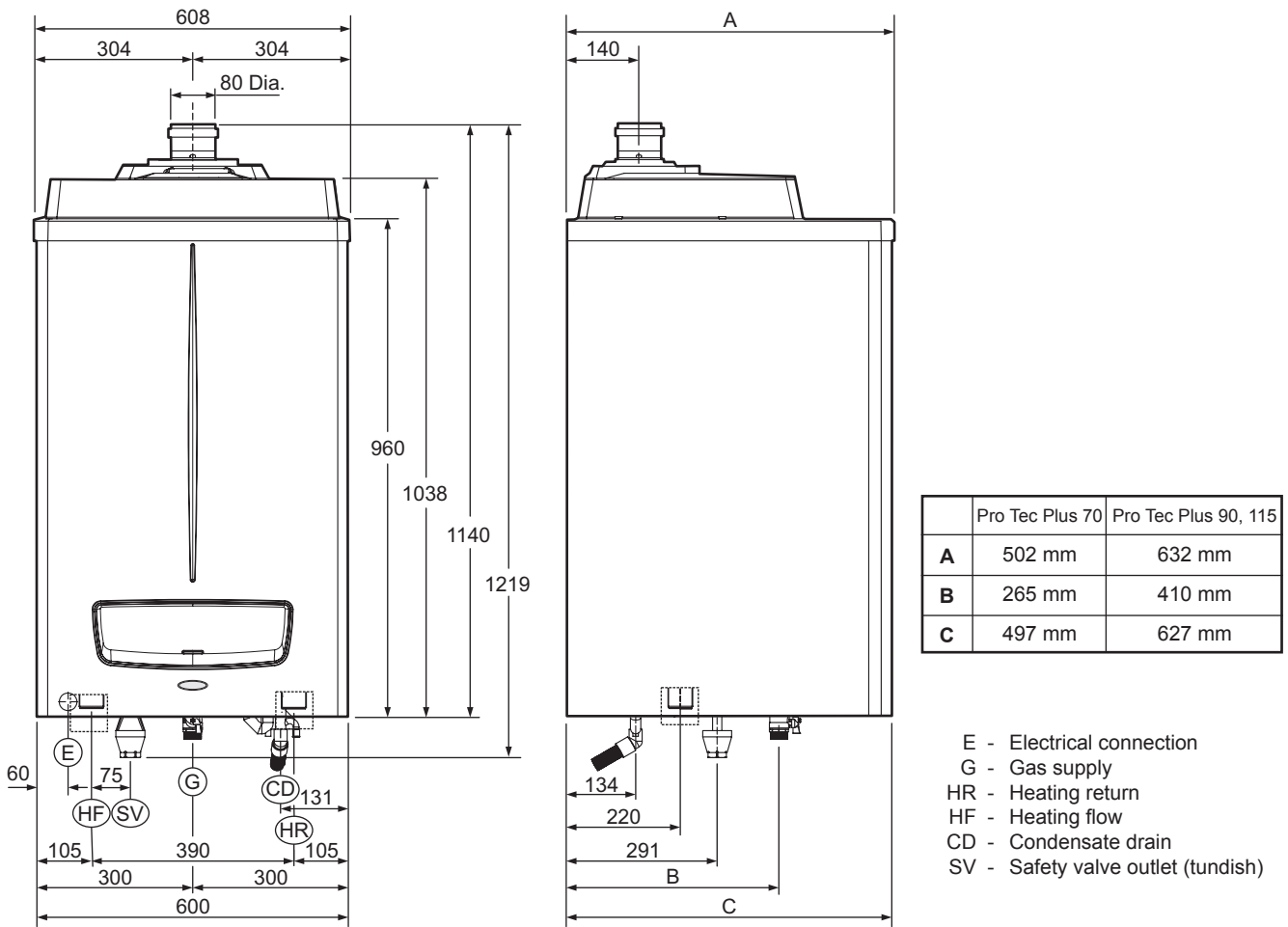

Fig. 5.2

5.3 PREPARE THE WALL - Fig. 5.3

1. Decide upon the position of the boiler taking into account the clearances required for servicing (refer to Section 3.2) and the flue terminal position.
2. Tape the template to the wall (ensure it is level and the right way up) and mark the position of the two holes for the boiler mounting hooks.
3. Drill the fixing holes (12 mm dia.) to accept the No. 12 plugs supplied. Screw the boiler mounting hooks fully into the plugs.
4. Cut suitable holes in the wall/roof 100 mm dia for open flue 80 mm dia. pipe or 127 mm dia. for concentric flue. Use the centre line positions given on the flue template.
5. Lift the boiler and locate it on the mounting hooks.

Note: When handling or lifting always use safe techniques - keep your back straight, bend your knees, don't twist - move your feet, avoid bending forwards and sideways and keep the load as close to your body as possible. Where possible transport the boiler using a sack truck or other suitable trolley. Always grip the boiler firmly, and before lifting feel where the weight is concentrated to establish the centre of gravity, repositioning yourself as necessary.

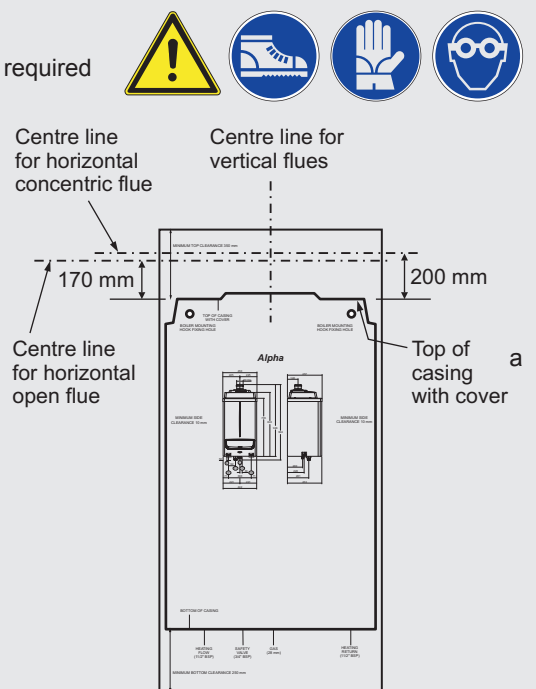

Fig. 5.3

5.4 CONNECT THE PIPEWORK

1. Thoroughly flush out all the system pipework. Refer to Section 4.10.
2. Connect the system flow and return pipework to the boiler using suitable isolating valves.
Note: Do not forget that the pressure relief valve discharge pipe must be routed clear of the boiler to a drain in such a manner that it may be seen, but cannot cause injury to persons or property.
3. Connect the 22 mm condensate trap drain pipe to the condensate discharge pipe using the adaptor supplied.
Ensure that the condensate discharge pipe is as required in Section 4.11.
Pour at least 1 litre of water into the flue duct, as shown in Fig. 5.4, and check the condensate discharge pipe for soundness
4. Ensure that all the valves are closed and do not turn on the water or gas supplies at this stage.

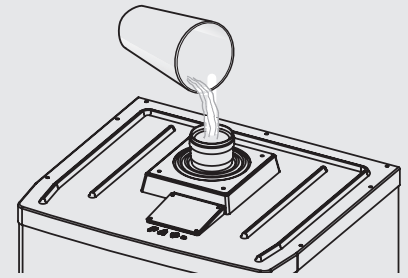

Fig. 5.4

5.5 'B23' TYPE SINGLE PIPE 80 mm FLUE KITS

Vertical kit - see Fig. 5.5 and 5.6, and refer to Section 4.4.

Fig. 5.5 shows the vertical flue kit parts.

To assemble the kit to the boiler - Slide the flue pipe down through the roof seal and place the seal over the flue duct. Push the flue duct into the flue socket on top of the boiler up to the stop. Ensure the seal is pushed in position against the ceiling.

To install extensions or other flue components, proceed as follows: fit the male end of the pipe or elbow up to the stop on the female socket (with lip seals) of the previously installed component, this will ensure a secure fit and seal of the joints. Ensure all joints have the seal located correctly and support clamps are fitted to ensure the flue ducts cannot be pulled apart.

It is recommended that the flue should be supported at least every 1.5 m with access provided to the joints.

All joints between flue sections should be connected using the clamps provided. It is not required to add additional screws through the clamps and into the flue sections.

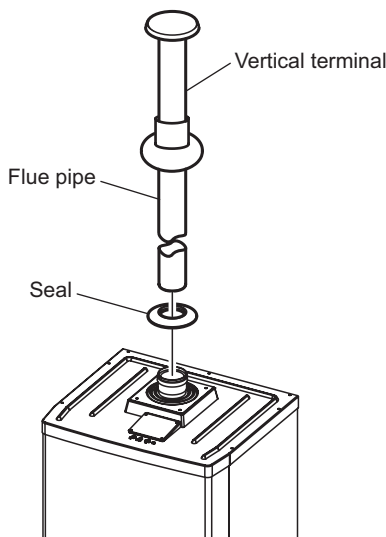
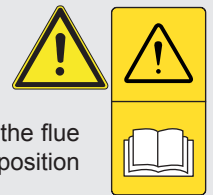

Fig. 5.5

Single vertical pipe 80 mm diameter	L Max.
Pro Tec Plus 50	30 m
Pro Tec Plus 70	28 m
Pro Tec Plus 90	14 m
Pro Tec Plus 115	8.5 m

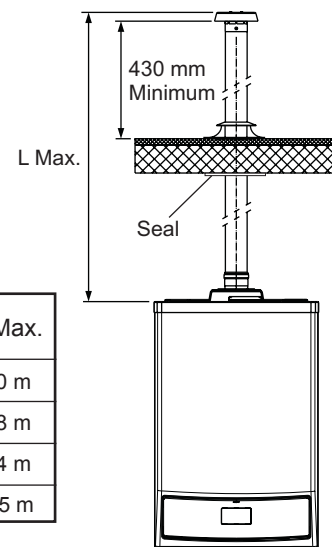

Fig. 5.6

Horizontal through the wall kit - see Fig. 5.7 and 5.8, and refer to Section 4.4.

Figs. 5.8 and 5.9 show the horizontal through the wall kit parts.

To assemble the kit to the boiler - Fit the male end of the flue elbow into central flue outlet on the top of the boiler to the stop. Place the outer seal over the flue duct and slide it through the wall from the outside. Place the inner seal over the flue duct then insert the duct into the elbow up to the stop. Slide the seals along the duct to seal it to the inside and outside of the wall.

To install extensions or other flue components, proceed as follows: fit the male end (smooth) of the pipe or elbow up to the stop on the female socket (with lip seals) of the previously installed component, this will ensure a secure fit and seal of the joints.

Note: To prevent condensate lying in the flue pipe, slope the pipe towards the boilers with a minimum slope of 2.5° - 3° (25 - 30 mm per metre). When installing the extensions, a wall/ceiling mounted clamp must be installed at least every 1.5 metres.

All joints between flue sections should be connected using the clamps provided. It is not required to add additional screws through the clamps and into the flue sections.

Fig. 5.7

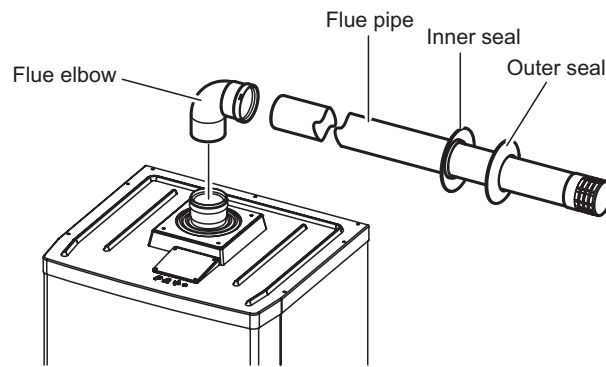
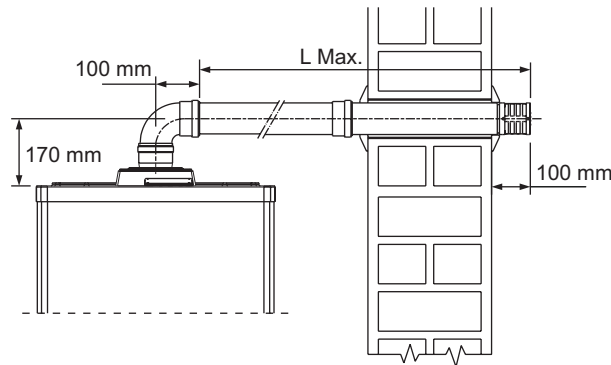

Fig. 5.8



Single horizontal pipe 80 mm diameter	L Max.
Pro Tec Plus 50	30 m
Pro Tec Plus 70	28 m
Pro Tec Plus 90	14 m
Pro Tec Plus 115	8.5 m

Note: Ensure the flue slopes downwards towards the boiler by a minimum of 25 to 30 mm per metre (2.5° to 3°)

5.6 'C' TYPE CONCENTRIC FLUE KITS

Convert the boiler from the factory supplied 'B23' type configuration to 'C' type, i.e. room sealed concentric flue by removing the 80 mm dia. adaptor and four screws securing the fixing plate and gasket from the top of the boiler.

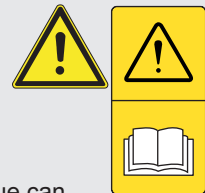

Horizontal through the wall concentric flue kit - see Fig. 5.9 and 5.10.

Fig. 5.9 shows the flue kit parts that need to be fitted to the boiler to ensure the room sealed concentric flue can be used.

To assemble the kit to the boiler - Fit the adapter into the central flue outlet on the top of the boiler up to the stop. Slide the square gasket over the adapter up to the groove, then fix it to the cover by means of the previously removed fixing plate and four screws. Fit the male end of the flue elbow up to the stop on the adapter. Place the outer seal over the concentric flue pipe and slide it through the wall from the outside. Place the inner seal over the concentric flue pipe then insert the pipe into the elbow up to the stop. Slide the seals along the duct to seal it to the inside and outside of the wall.

To install extensions or other flue components, proceed as follows: fit the male end (smooth) of the concentric pipe or concentric elbow up to the stop on the female socket (with lip seals) of the previously installed component, this will ensure a secure fit and seal of the joints.

Note: To prevent condensate lying in the flue pipe, slope the pipe towards the boilers with a minimum slope of 3° (25 - 30 mm per metre). When installing the extensions, a wall/ceiling mounted clamp must be installed every 1.5 metres.

All joints between flue sections should be connected using the clamps provided. It is not required to add additional screws through the clamps and into the flue sections.

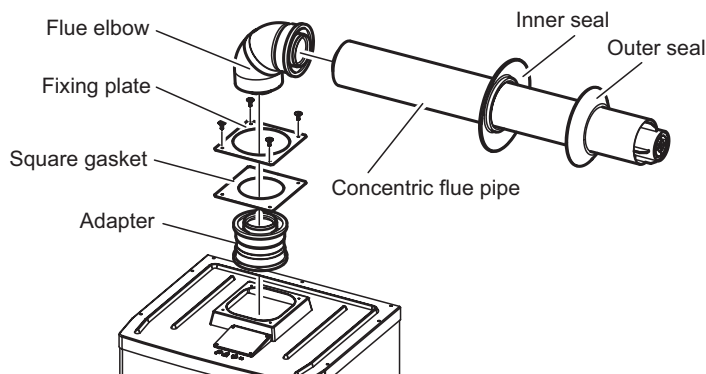

Concentric Flue

Horizontal and vertical 80/125 mm diameter	L Max.
Pro Tec Plus 50	14.5 m
Pro Tec Plus 70	11 m
Pro Tec Plus 90	8 m
Pro Tec Plus 115	5 m

Fig. 5.9

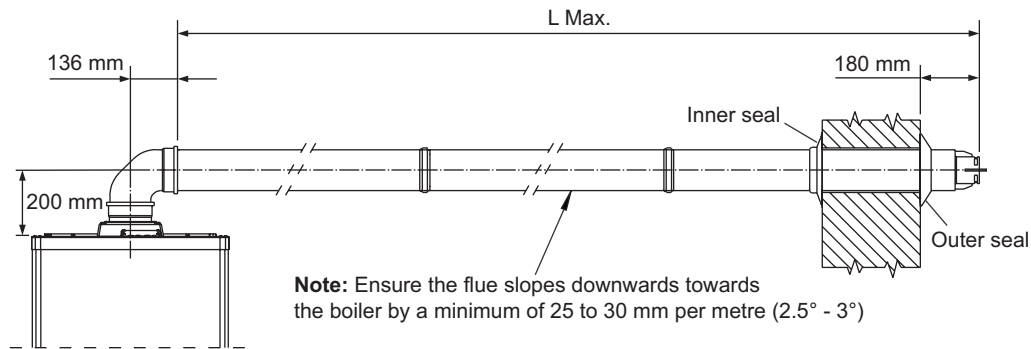

Fig. 5.10

5.7 CONNECT THE MAINS SUPPLY AND EXTERNAL CONTROLS - Fig. 5.11



Gain access as described below while referring to Fig. 5.11, page 22.

1. Remove the case front panel as follows:
 - a. Remove the two screws (1) from the bottom of the front panel (2).
 - b. Grip the handle in the bottom of the panel and pull it forwards to detach it from the central catches (3) then slide it down from the top fixings (4) and remove.
2. Remove the two screws and washers (5) securing the sides of the control panel. Press the two side hooks (6) and tilt the control panel (7) forwards.
Remove the three screws (8) securing the control box cover (9) to gain access to the terminal block.
Refer to Technical Data, Section 3.6 for connection details.
Note: This boiler has been fitted with a mains supply cable. However, if it is necessary to fit an alternative supply cable, ensure the cable clamp that has been fitted is removed and connect as follows:-
Pass the mains supply cable through the cable clamp and connect as follows:- Brown to L, Blue to N and Green/Yellow to \perp . Ensure correct polarity.
Note: Ensure that the length of the earth wire is such that if the supply cable is pulled out of its clamp the live and neutral wires become taut before the earth wire.
Do not switch on the electrical supply at this stage.
3. **If any external control, i.e. room thermostat etc. is to be fitted, refer to Fig. 3.5.**
Do not connect 220/240 volts to any of the other terminals.

It is recommended that only the mains supply is connected to the boiler when first commissioning. External controls can then be connected after the boiler has been commissioned. This prevents any external controls interrupting the commissioning process.

4. Ensure that there is sufficient free cable to allow the control panel to be raised and lowered then tighten the cable clamp screws.
5. Leave the control panel open until commissioning procedures have been completed.
6. Carry out electrical system checks - Short circuit, Polarity, Earth continuity and Resistance to earth with a suitable multimeter.

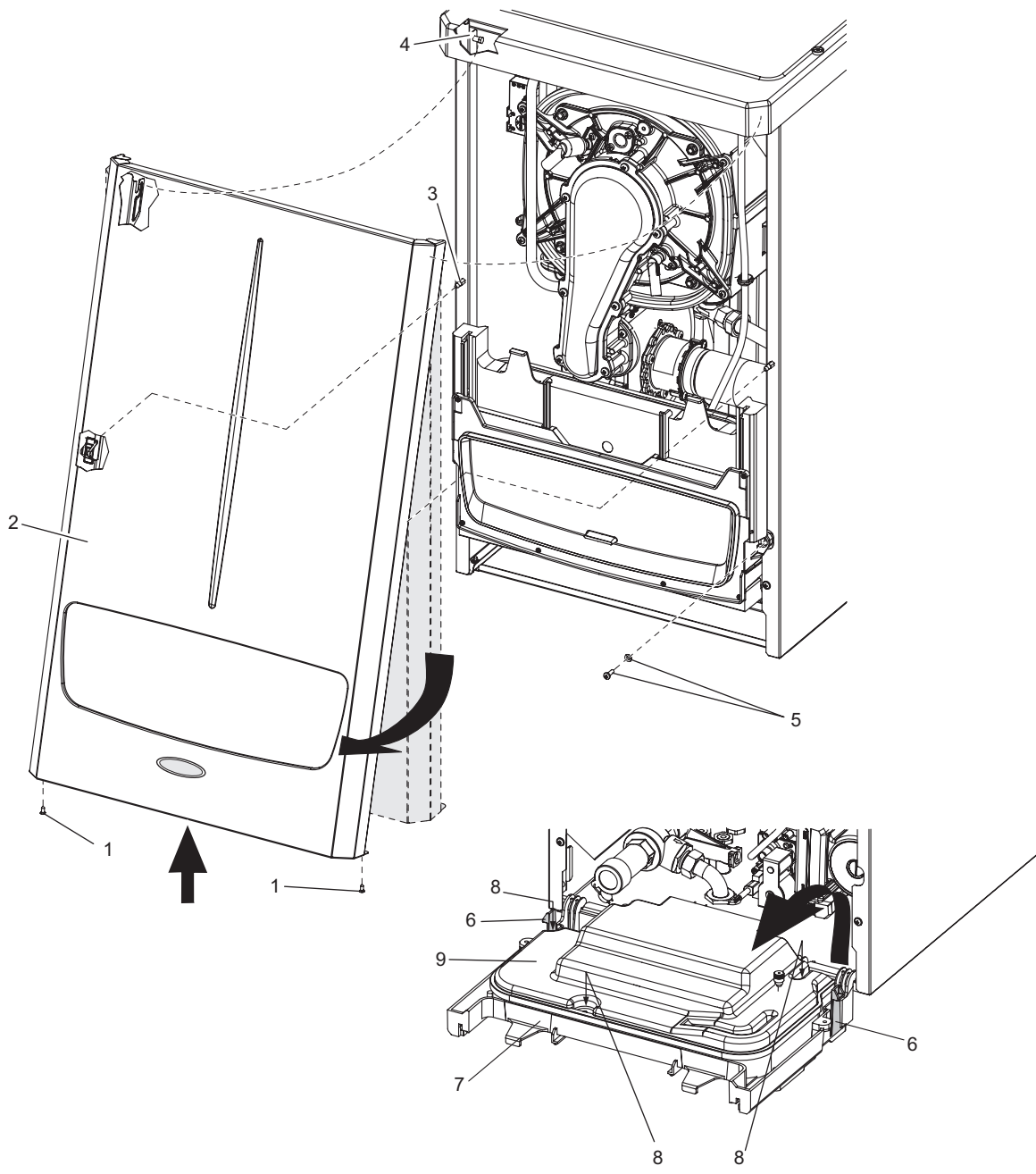

Fig. 5.11

5.8 EXTERNAL TEMPERATURE PROBE - Fig. 5.12



Alpha Pro Tec Plus boilers can be controlled using the Alpha Single Boiler Controller (available as an optional kit), or with the installation of an alternative programmer/room thermostat. These must be 'volt free' switching. In either scenario the external probe can be connected directly to the boiler electrical connections G and J, refer to the external probe instruction sheet for positioning on an external wall.

The function of the probe is to automatically increase/decrease the flow temperature of the boiler according to the changes in external temperature.

By default the external probe is not enabled (factory set to 0), it is therefore necessary to set the parameters P14 and P15, refer to Section 10, page 37.

P14 sets the operating gradient - select between 1 and 10, P15 sets the minimum flow temperature for the selected gradient, this is set to 30°C as default.

The correlation between boiler flow temperature and external temperature is determined by the curves shown in Fig. 5.12.

Note: Should P32 (minimum CH set point) be set at a higher value than P15 then this shall be the minimum flow temperature.

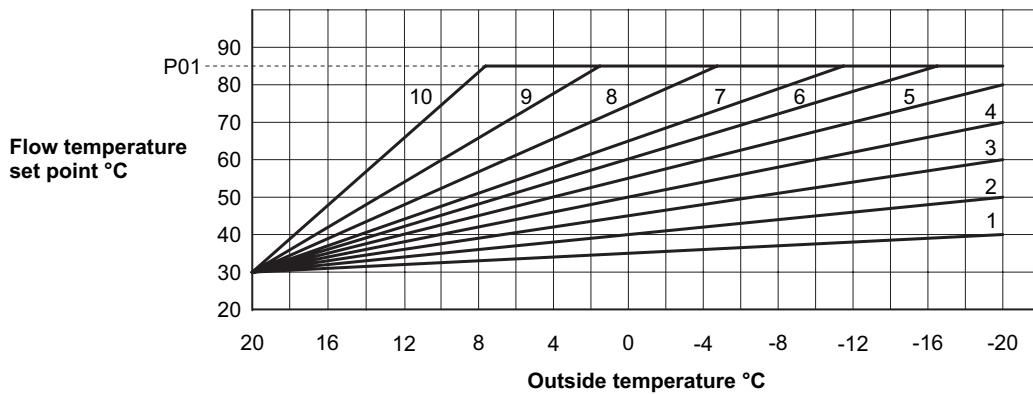

Fig. 5.12

6 COMMISSIONING and USING THE BOILER

When commissioning the boiler, ensure the Benchmark Checklist at the back of these instructions is completed.



6.1 FILL THE SYSTEM

If the front cover has not been removed, refer to Fig. 5.11.

1. The Pro Tec Plus 50 has two automatic air vents (see Fig. 7.4), the Pro Tec Plus 70, 90, 115 boilers have one automatic air vent (see Fig. 7.5). Ensure that these are always open.
2. Open the central heating flow and return valves.
3. Open the fill point valve on the filling loop until water is heard to flow.
4. To remove the air - Vent each radiator in turn, starting with the lowest in the system.

Note: The Pro Tec Plus 50 model **must be** vented using the manual air vent on the top left of the heat exchanger (see Fig. 7.4).

5. It is important that the pump (see Fig. 7.4 or 7.5) is properly vented to avoid it running dry and damaging its bearings. Unscrew and remove the cap from the centre of the pump. Using a suitable screwdriver rotate the exposed spindle about half a turn, then replace the cap.
6. Check the operation of the safety valve (see Fig. 7.4 or 7.5) by turning the head anti-clockwise until it clicks. The click is the valve lifting off its seat allowing water to escape from the system - check that this is actually happening.
7. Continue to fill the system until the pressure gauge indicates 1.0 bar. Close the fill point valve and check the system for water leaks, rectifying where necessary. Disconnect the filling loop from the mains supply. If the system has been over pressurised water may be released from the system by manually operating the drain point (see Fig. 3.7 or 3.8) until the system design pressure is obtained. The system design pressure (cold) should be between 0.75 and 1.25 bar.

Refer to Sections 4.9 and 4.10. Filling and Flushing the system.

6.2 TEST FOR GAS TIGHTNESS AND PURGE THE SUPPLY

1. With the boiler gas service cock closed. Pressure test the gas supply and inlet pipework connection to the boiler gas service cock for tightness in accordance with BS 6891 and IGE UP/1, 1A and 1B.
2. Loosen the gas inlet pressure test point screw on the gas valve (see Fig. 6.1). Ensure the gas supply is on and open the boiler service cock to purge in accordance with BS 6891 and IGE UP/1, 1A and 1B.
3. Retighten the test point screw and test for gas tightness. Close the boiler gas service cock.



Pro Tec Plus 50, 70 gas valve

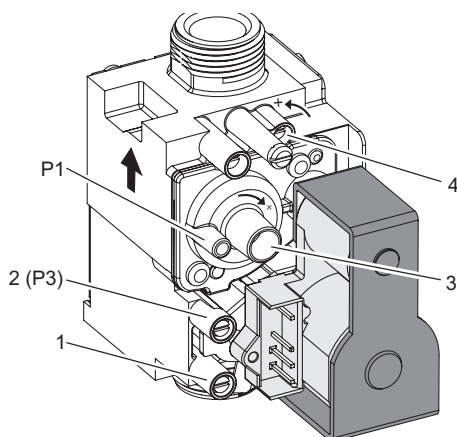

- 1 - Inlet gas pressure point
- 2 - Outlet gas pressure point
- 3 - Off/Set adjustment screw (minimum)
- 4 - Outlet flow regulator (maximum)

Pro Tec Plus 90, 115 gas valve

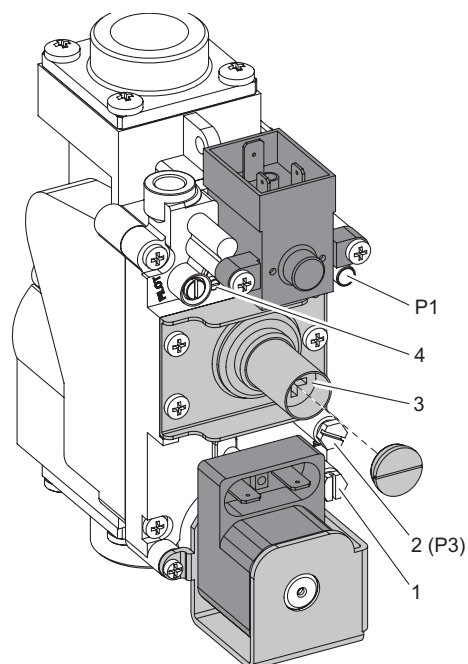
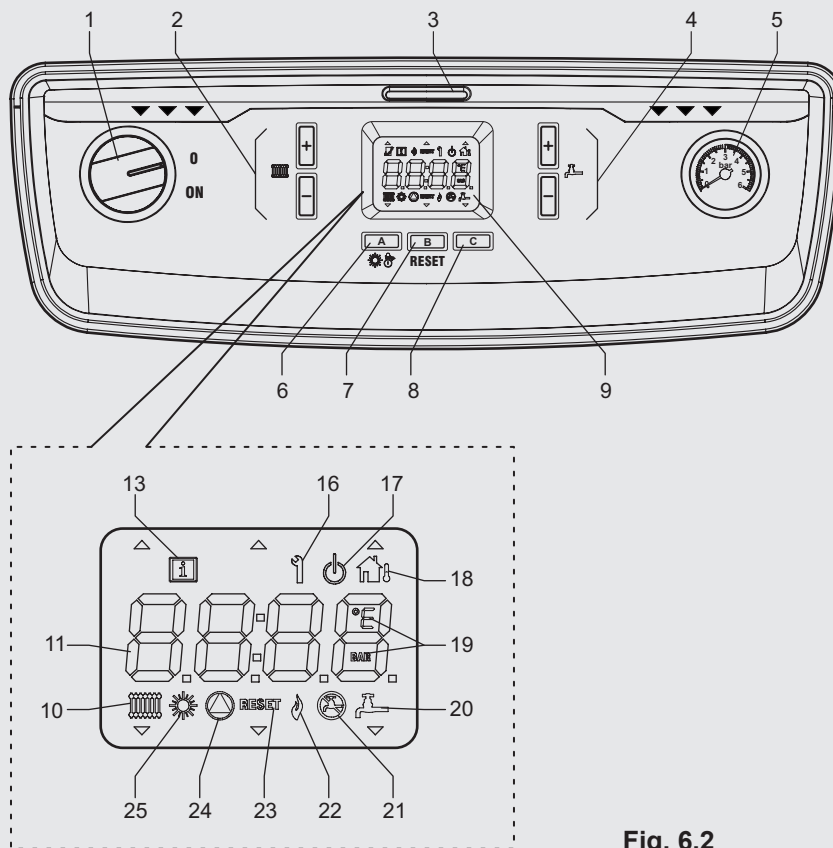

Fig. 6.1

6.3 BOILER CONTROLS - Fig. 6.2

Raise the control panel cover using the handle '3' in Fig. 5.2.



- 1 - On/Off switch
- 2 - Main flow temperature - Increase or Decrease
- 3 - Control panel cover handle
- 4 - DHW temperature - Increase or Decrease (optional)
- 5 - System pressure gauge
- 6 - Summer/Winter mode/Chimney sweep selector button (A)
- 7 - Reset and information button (B)
- 8 - Hot water enable/disable and Fault history button (C)
- 9 - LCD display
- 10 - Heating request
- 11 - Numeric indicators - Temperature, Info and Fault codes
- 12 - N/A
- 13 - Information icon
- 14 - N/A
- 15 - N/A
- 16 - Engineer mode for system setup
- 17 - Standby mode
- 18 - External temperature feature (optional)
- 19 - Measurement value units
- 20 - DHW function active (optional)
- 21 - DHW function disabled
- 22 - Burner ON
- 23 - Reset required
- 24 - Internal pump running
- 25 - Summer mode active

Fig. 6.2

6.4 BOILER LCD DISPLAY AND CONTROL BUTTONS

The boiler display (see Fig. 6.2), is composed of a 4-character display and 7 buttons. By using these buttons it is possible to adjust the boiler as it would be by using traditional selector switches and knobs.

The function of each button is listed in Fig. 6.2.

When the boiler is operating, the display indicates the mode icons and the boiler flow temperature.

6.5 INITIAL LIGHTING - Refer to Fig. 6.2

1. Ensure that the gas and electrical supplies to the boiler are off and that the heating flow and return valves are open.
2. Check that the system has been pressurised to the required pressure (at least 1 bar).
3. Turn on the gas and electrical supplies to the boiler.
4. Ensure any external controls are calling for heat.
5. Set the On/Off switch to ON.

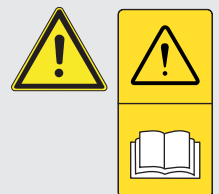

The boiler pump will run through a brief air purging cycle. At the beginning of this cycle the display will check the software and connections.

When the purge cycle is complete the boiler will then respond to the request of the heating controls and the burner will light if a demand is present. The boiler will only fire at low level initially and will ramp up gradually according to the heat demand.

Allow the boiler to run and heat the circuit, checking for leaks and correct circulation, testing any secondary circuits and zone controls for correct operation.

During operation gas working pressure, gas rate and combustion checks can be conducted using the engineering function. Refer to Section 6.7.

Air Flow Control Function

When a heat demand is given, before firing a check is made that the air pressure switch contacts are open circuit. If the air pressure switch contact is closed, the ignition cycle stops and after approximately 50 seconds the fault 0A4 is displayed.

If the air pressure switch circuit is open the fan starts and the pressure switch then closes checking a free flow in the flue circuit. Then the fan runs at ignition speed and the ignition cycle commences. If during the cycle the pressure switch doesn't close the contacts (i.e. the flue system is blocked or restricted), after 50 seconds fault A4 is displayed.



'A' operating mode button (☀️ ⚙️) - With the boiler on, press button 'A' repeatedly to change the operating mode. It will switch from Summer mode (☀️) (DHW only, when the optional kit is installed) to Winter mode (DHW and heating), alternately.

With the boiler on but not running, the screen will display the flow sensor temperature reading.

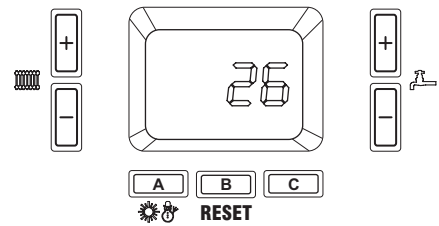

Fig. 6.3

When the boiler switches on the relative symbols will be displayed and the flow sensor temperature reading shown.

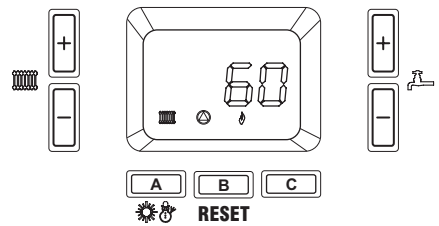

Fig. 6.4

Summer (☀️) - In this mode the boiler only operates for DHW heating (optional kit).

By pressing the + or - buttons (as shown in Fig. 6.5) just once it is possible to read the DHW temperature setting. By pressing them again you can change the settings as needed. You will need to press button 'B' to save the new value. The temperature reading will flash during adjustment. If a certain amount of time lapses without saving the value, the boiler will exit the setting mode and maintain the previous setting.

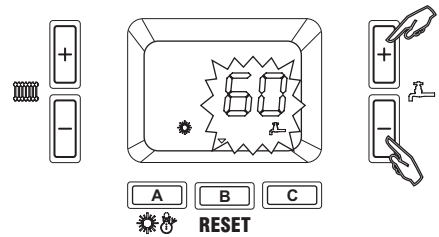

Fig. 6.5

Winter (⚙️) - In this mode the boiler provides both DHW and heating.

By pressing the + or - buttons (as shown in Fig. 6.6) once, you can view the flow temperature setting. By pressing them again you can change the setting as needed. You will need to press button 'B' to save the new value. The temperature reading will flash during adjustment. If a certain amount of time lapses without saving the value, the boiler will exit the setting mode and maintain the previous setting.

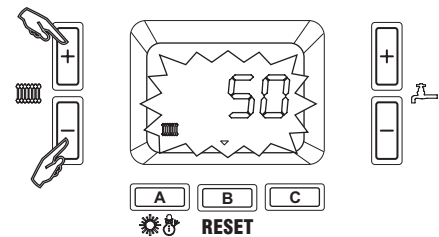

Fig. 6.6

Stand-by mode (⏻) - By pressing buttons 'A' and 'C' (as shown in Fig. 6.7) at the same time it is possible to place the boiler in the standby mode.

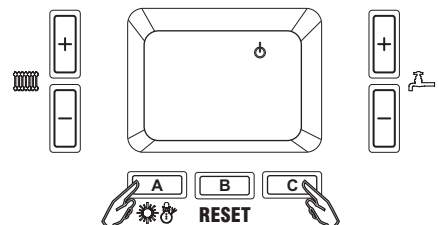

Fig. 6.7

In the standby mode the boiler is still switched on but not active, maintaining the anti-freeze function. To turn it back on simply press button 'B'.

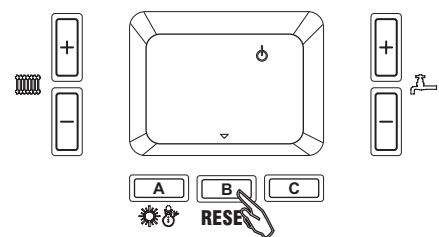

Fig. 6.8

DHW exclusion (☹) - With the boiler set up for DHW heating, press button 'C' momentarily to exclude the DHW heating mode operation. To return to the DHW heating mode, press button 'C' again as shown in Fig. 6.9.

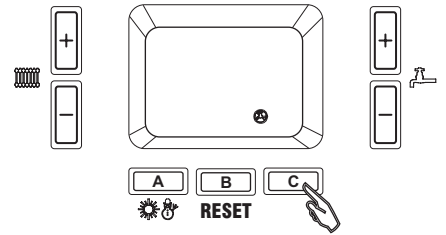

Fig. 6.9

Fault records - Press and hold button 'C' in to access the records of the last 8 faults that have affected the boiler (list from H i 0 to H i 7, where H i 0 is the most recent fault). When you are in the menu, the screen will display, in order, number 'bu 0', the number and code for the anomaly.

To scroll through the list, press the + and - buttons (as shown in Fig. 6.10).

To exit the menu, press and hold button 'C' in again.

Note: Faults with the “FE” code are not saved in the fault records.

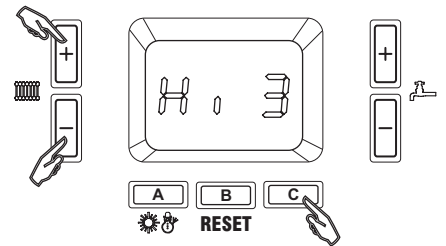

Fig. 6.10

Information menu - Press and hold in 'B' to access the information menu containing all of the various information relative to the boiler operation.

Once you have accessed the menu, you will momentarily see the parameter number followed by the value.

To scroll through the various parameters, press the + and - buttons (as shown in Fig. 6.11).

To exit the menu, press and hold 'B' in again.

While the parameter value is being displayed it is possible to momentarily see the relative code again by pressing button 'A'. The viewable parameters are listed in the following table.

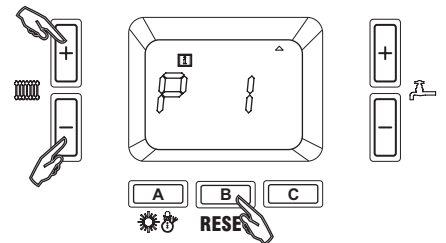

Fig. 6.11

Table of viewable parameters



Menu item	Description	Unit of measurement
P01	Flame current	μA
P02	Flow sensor temperature reading	°C / °F
P03	Return sensor temperature reading	°C / °F
P04	DHW sensor temperature reading (if installed)	°C / °F
P05	System water flow (boiler circuit)	l / minute
P06	Operating power (burner modulation)	%
P07	Fan speed requested by system	RPM / 50
P08	Current fan speed	RPM / 50
P09	Flue sensor temperature reading	°C / °F
P10	External flow sensor reading (if fitted)	°C / °F
P11	External sensor temperature reading (if installed)	°C / °F
P12	Simple cascade power (modulation)	%
P13	Flow temperature requested by system in heating	°C / °F
P14	Flow temperature requested by system in DHW	°C / °F
P15	Not used	-
P16	Number of burner cycles in simple cascade (cascade only)	No.
P17	Number of display counted (cascade only)	No.

6.7 FINAL COMMISSIONING

1. Allow the heating system to heat up, then balance the system to achieve the necessary temperature difference across the heating flow and return pipes at the boiler and check the system volume and pressure. (Refer to Technical Data, Section 2.1).
2. Turn off the boiler.
4. Thoroughly flush out the water pipework (refer to Section 4.10).
5. Re-pressurise the system as described in Section 6.1.

6.8 CHIMNEY SWEEP FUNCTION - COMBUSTION CHECKING

This function allows the combustion and gas rate checks to be conducted according to the data tables in Section 3.3. In the engineering function the boiler output can be adjusted between 0% and 100% of the output range (Minimum to Maximum output).

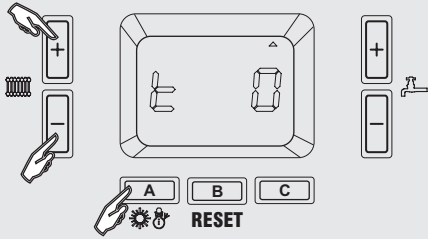

Fig. 6.12

To activate this function press and hold in button 'A'. 't0' will be displayed

indicating minimum output (0%) and check the CO₂ value according to the table in Section 3.3. Then select maximum output (100%) by pressing the DHW + button, again checking the CO₂ value and gas supply working pressure as specified in the table in Section 3.3.

Output values between 0% and 100% can be selected using the CH + and - buttons to change the value in 1% increments. This function can be used to hold the boiler at a desired output level and conduct system tests and checks.

During this function all external controls and thermostats are inactive and only the overheat thermostats and safety controls remain active. This function can be exited by pressing and holding in button 'A'.

If you enable this function, please wait 1 minute to allow the burner to reach the desired output and stabilise.

6.9 FINAL ASSEMBLY

1. Raise and secure the control panel, replace the front cover and secure in position with the screws previously removed.
2. If the boiler is to be left in service with the User, set any external controls to the User's requirements.
3. If the boiler is not to be handed over immediately, close the boiler gas service cock and switch off the electrical supply.
4. If there is any possibility of the boiler being left during frost conditions, then the boiler and system should be drained. It is recommended that a label is attached to the boiler drawing attention to the fact that the system has been drained.
5. Complete the details of the installation in the Benchmark Checklist at the back of this manual.



6.10 USER INFORMATION

The User must be advised (and demonstrate if necessary) of the following important points:-

1. How to light and turn off the boiler and how to operate any external system controls.
2. The importance of annual servicing of the boiler to ensure safe and efficient operation.
3. That any servicing or replacement of parts must only be carried out by Gas Safe registered personnel.
4. Ensure that the boiler controls are set to the User's requirements.
5. Tell the User about the sealed system pressure.
6. Tell the User that if the electrical supply is on and the boiler has not operated for 24 hours, the pump will automatically operate for 5 minutes.
7. Explain to the User that an internal frost thermostat is fitted in the boiler, and that the electrical supply to the boiler must be left on for the thermostat to operate.
8. Explain to the User that in certain weather conditions the flue terminal will emit a plume of steam, i.e. water vapour. This is safe and quite normal.
9. Show the User the position of the pressure relief valve and condensate discharge pipes.
10. Hand the User's instructions to the User.
11. Ensure the Benchmark Checklist at the back of this manual has been completed after the boiler has been installed and commissioned.

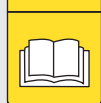

Note: It is a requirement that the installation is registered by the installer through the Gas Safe Gas Work Notification Scheme.

12. Leave these Installation and Servicing instructions with the User for use on future calls.

7 ROUTINE SERVICING

To ensure efficient operation the boiler must be checked and serviced as necessary at regular intervals. The frequency of servicing will depend upon the particular installation conditions and usage, this must be at least once per year to maintain the boiler guarantee.

It is the law that any service work must be carried out by a competent person, i.e. Gas Safe registered personnel.

Warning: Before servicing the boiler, isolate the electrical supply and close the boiler gas service cock. Allow the boiler to cool.

The data label is positioned on the inside of the right hand side of the base plate.

Always test for gas tightness after servicing any gas carrying components.

Always carry out electrical system checks i.e. Earth Continuity, Resistance to Earth, Short Circuit and Polarity with a suitable meter after servicing.

General

Please Note: During routine servicing, and after any maintenance or change of part of the combustion circuit, the following must be checked:

1. The integrity of the flue system and the flue seals.
2. The integrity of the boiler combustion circuit and relevant seals.
3. The operational (working) gas inlet pressure at maximum rate.
4. The combustion performance, as described below.

Competence to carry out the check of combustion performance

Please Note: BS 6798:2009 Specification for installation and maintenance of gas-fired boilers of rated input not exceeding 70 kW net advises that:

1. The person carrying out a combustion measurement should have been assessed as competent in the use of a flue analyser and the interpretation of the results.
2. The flue gas analyser used should be one meeting the requirements of BS 7927 or BS-EN 50379-3 and be calibrated in accordance with the analyser manufacturers' requirements.

Combustion check

Prior to servicing a flue gas analyser must be used to measure the performance of the boiler at minimum and maximum fire conditions (refer to Section 6.7). Repeat the flue gas analyser tests after servicing and cleaning the heat exchanger checking the CO₂ readings at high and low fire are within the specified values given in Section 3.3.

Connect the flue gas analyser to the flue gas sampling point as shown in Fig. 7.4 or 7.5.

If the CO₂ readings are incorrect following inspection and cleaning of the heat exchanger and all other checks below have been carried out, it may be necessary to adjust the gas value to give the correct combustion readings.

If the combustion readings are still un-acceptable and the integrity of the complete flue system, combustion circuit and gas inlet pressure have been verified. Please call our Technical Helpline for further assistance.

7.1 REQUIRED ACTIONS DURING ROUTINE SERVICING

1. Visually check the flue and terminal are sound and correct ventilation is available.
2. Remove the front case from the boiler and inspect internal components for leaks - signs of spillage/soot/burn marks.
3. Check electrical connections to the boiler, mains voltage test and controls operation.
4. Check and record boiler combustion at high and low fire conditions.
5. During high fire maximum condition check and record that the correct gas working pressure is available.
6. Remove the burner front and clean the heat exchanger coils with a soft brush and rinse with water.
7. Remove the boiler condensate trap, wash, clean out and replace the trap in position.
8. Check that the flow temperature and cylinder thermostat settings are correct.
9. Check all system expansion vessel pressures and operating pressures are within the correct range (max 5 bar DHW, max 3 bar CH/Primary).
10. Confirm correct operation of all safety valves.
11. Record all the required readings in the Service Record at the back of this manual.

To maintain the boiler guarantee all the above actions must be carried out and recorded in the Service Record at the back of this manual.



7.2 CASING REMOVAL - Figs. 5.11, 7.1

If required, the casing can be completely removed as follows:

1. Remove the case front panel as described in Section 5.7, paragraphs 1 and 2.
2. Remove the two screws and washers (5) securing the sides of the control panel. Press the two side hooks (6) and tilt the control panel (7) forwards.
3. Remove the bottom panel (10) by removing the four screws (11).
4. If necessary, you can remove the top cover (12) and side panels (14)

Loosen the seven screws (13) securing the top cover (12).

Remove the two screws (15) securing the side panel (14). Lift the side panel and pull it forwards unhooking it from the rear panel (view 'A' in Fig. 6.1) Lower the panel out and away from the top cover.

Note: If only the front panel is to be removed, remove as described in Section 5.7, paragraph 1.

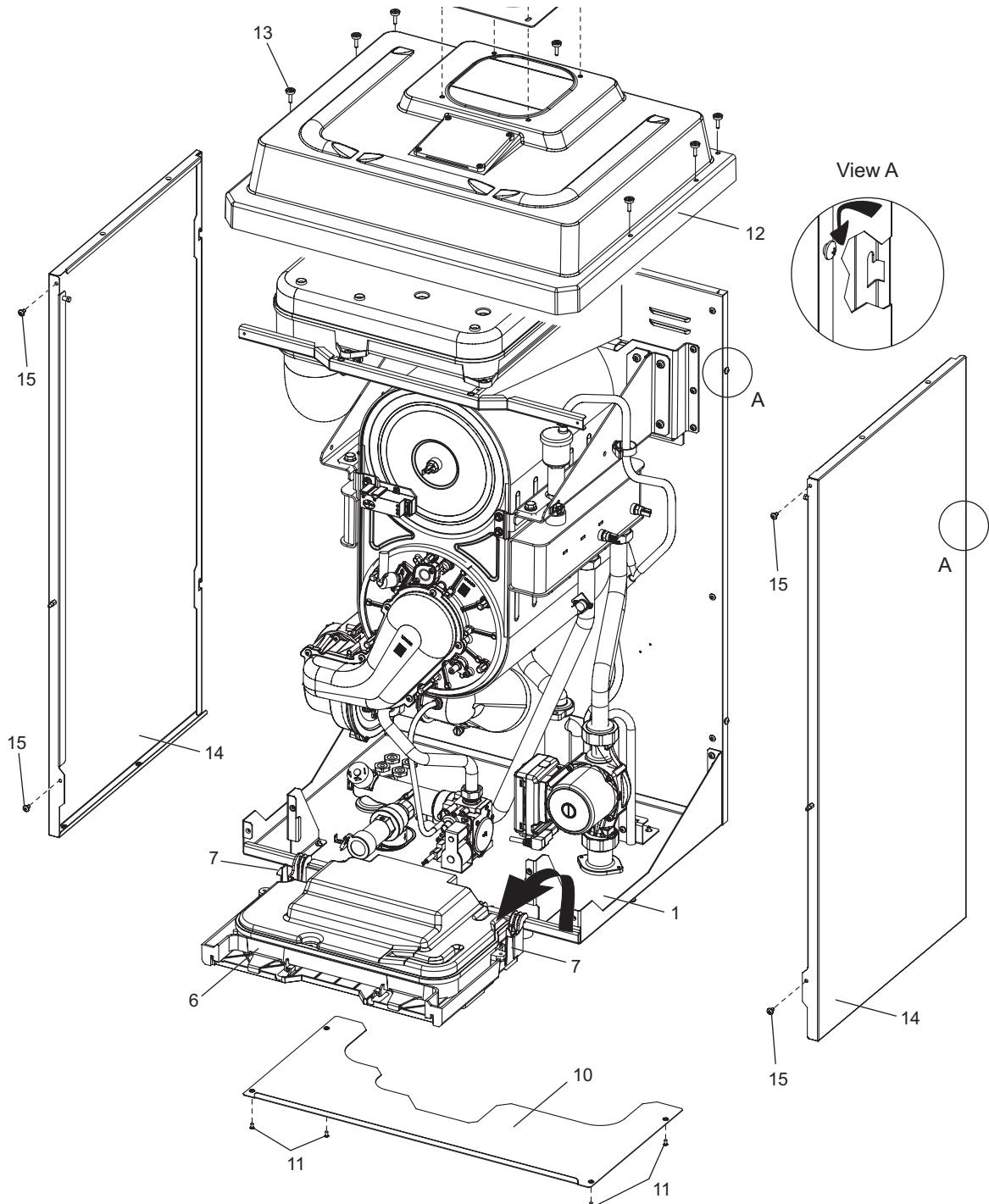

Fig. 7.1 (Pro Tec Plus 70 shown)

7.3 PREPARE FOR SERVICING - Fig. 7.4 or 7.5

1. Ensure the electrical supply is isolated and the gas supply is off.
2. Remove the front panel and lower the control panel as described in Section 5.7, paragraphs 1 and 2.

Pro Tec Plus 50 model

1. Disconnect the electrode lead from the ignition generator and the in-line connector to the flame sensing electrode.
2. Remove the two M4 screws securing the fan to the combustion chamber front.
3. Remove the four screws located on the end tabs securing the combustion chamber front to the boiler chassis.
4. Using a 10 mm ring spanner remove the four nuts securing the combustion chamber front to the heat exchanger. Slide the complete assembly from the heat exchanger.

Pro Tec Plus 70, 90, 115 models

1. Disconnect the gas supply pipe union from the burner manifold.
2. Remove the two screws securing the fan assembly to the combustion chamber front.
3. Disconnect the electrode lead from the ignition generator and the in-line connector to the flame sensing electrode.
4. Remove the six nuts and washers securing the combustion chamber front and remove the complete assembly.

7.4 CLEANING THE BOILER

1. Remove any deposits from heat exchanger using a suitable soft brush. Do not use a brush with metallic bristles.
2. Check the condition of the combustion chamber insulation panels.
3. Check the condition of the burner on the combustion chamber front assembly, carefully clean with a soft brush if necessary. Do not use a brush with metallic bristles as this might damage the burner.
4. Remove any deposits from the heat exchanger coils. This can be done by suction or water sprayed onto the coils. Ensure all electrical components are protected from water. Any water used to clean the heat exchanger will drain through the condensate trap.
5. Check the condition of the electrodes.
6. Check the spark gap, positioning and height of the electrodes. Refer to Fig. 7.2 or 7.3.
7. Remove the condensate trap drain to remove any deposits and flush with clean water.

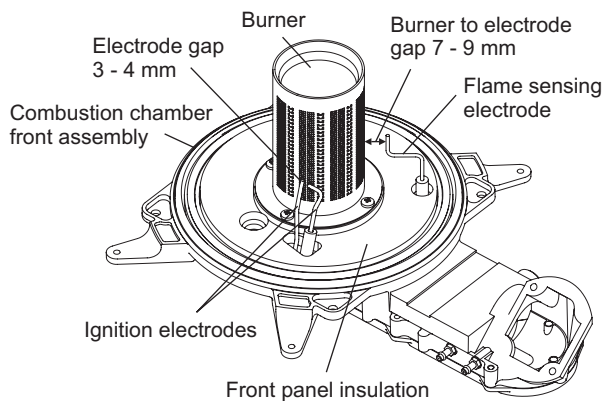

Fig. 7.2 - Pro Tec Plus 50

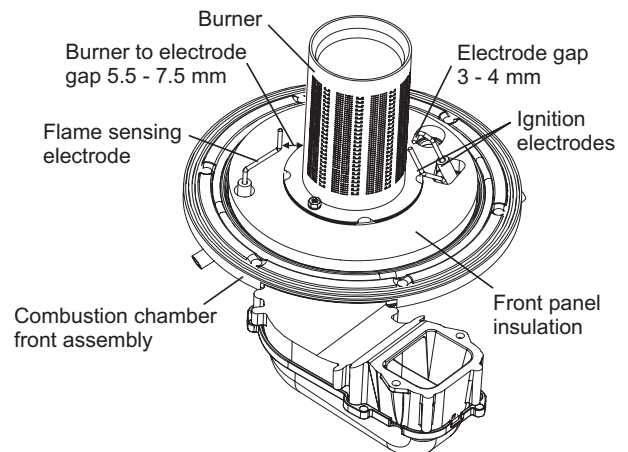
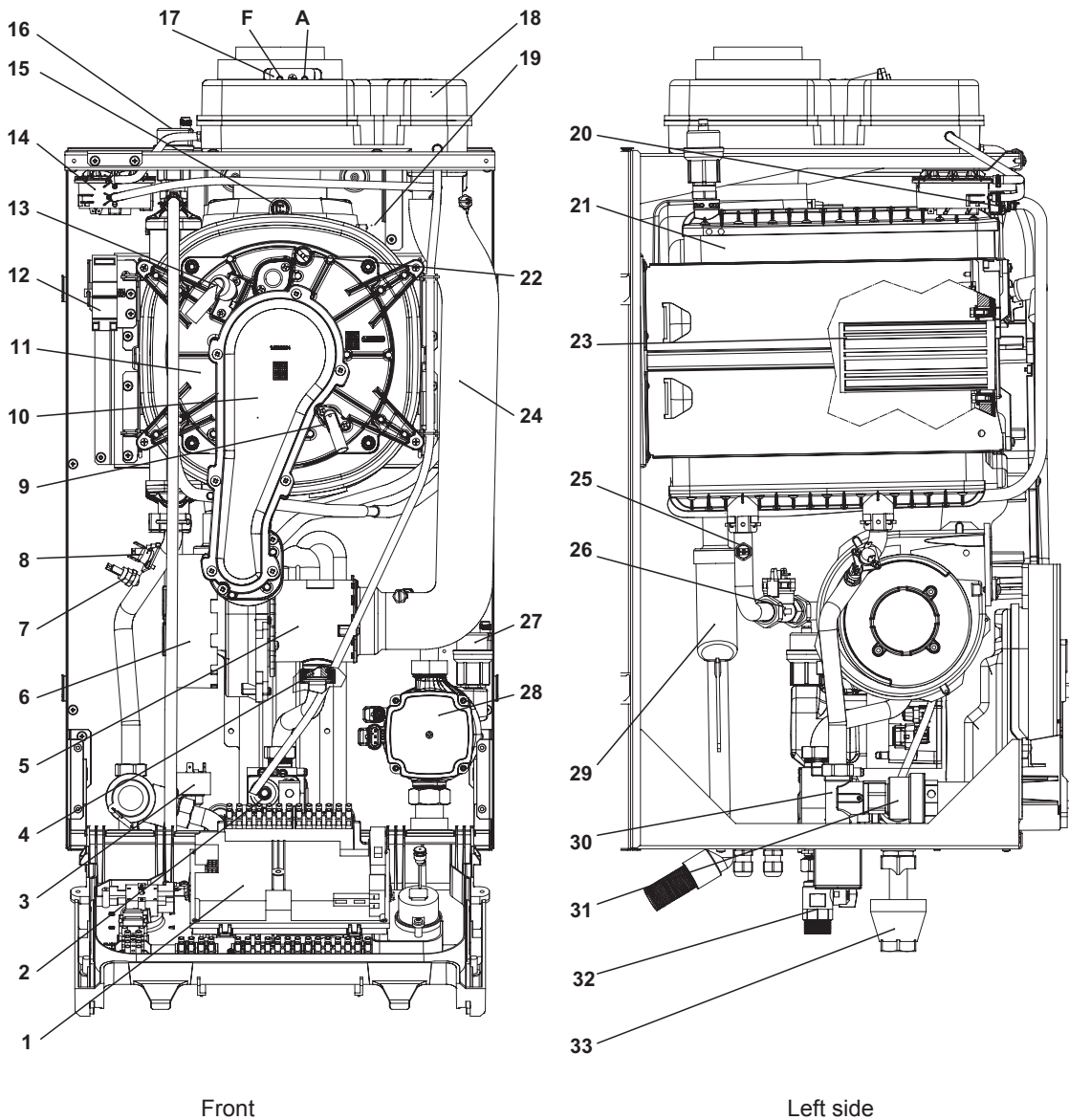

Fig. 7.3 - Pro Tec Plus 70, 90, 115

7.5 RE-ASSEMBLE THE BOILER

Important: Before replacing the combustion chamber front assembly, pour water into the coils of the heat exchanger. This is to ensure the condensate trap is full of water before operating the boiler.

1. Replace the combustion chamber front assembly, ensuring it is correctly located.
2. Ensure the electrode lead is connected.
3. Re-connect the gas pipe to the manifold, test the connections for gas tightness and re-commission, see Section 5.
4. Re-connect the fan assembly to the combustion chamber assembly.
5. Check combustion as described in Section 6.7
6. Check the operation of the boiler.
7. Return all controls to their original settings.
8. Place the case or front case panel in position and secure in position with the screws previously removed, see Section 7.2.



- | | | | |
|----|--------------------------------|----|------------------------------------|
| 1 | PCB | 18 | Flue hood manifold |
| 2 | Gas valve | 19 | Manual air vent |
| 3 | Pressure switch | 20 | Condensing heat exchanger |
| 4 | Injector | 21 | Heat exchanger thermal fuse |
| 5 | Venturi housing | 22 | Overheat thermostat (manual reset) |
| 6 | Fan | 23 | Burner |
| 7 | System flow NTC | 24 | Air intake pipe |
| 8 | Overheat thermostat | 25 | System return NTC |
| 9 | Flame detection electrode | 26 | Primary flow switch |
| 10 | Manifold cover | 27 | Automatic air vent |
| 11 | Combustion chamber front cover | 28 | Pump |
| 12 | Spark generator | 29 | Condensate trap |
| 13 | Ignition electrode | 30 | Flow manifold |
| 14 | Air pressure switch | 31 | Safety valve 4 bar |
| 15 | Flue sensor | 32 | Gas cock |
| 16 | Automatic air vent | 33 | Tundish |
| 17 | Test points (air A) - (flue F) | | |

Fig. 7.4 Pro Tec Plus 50

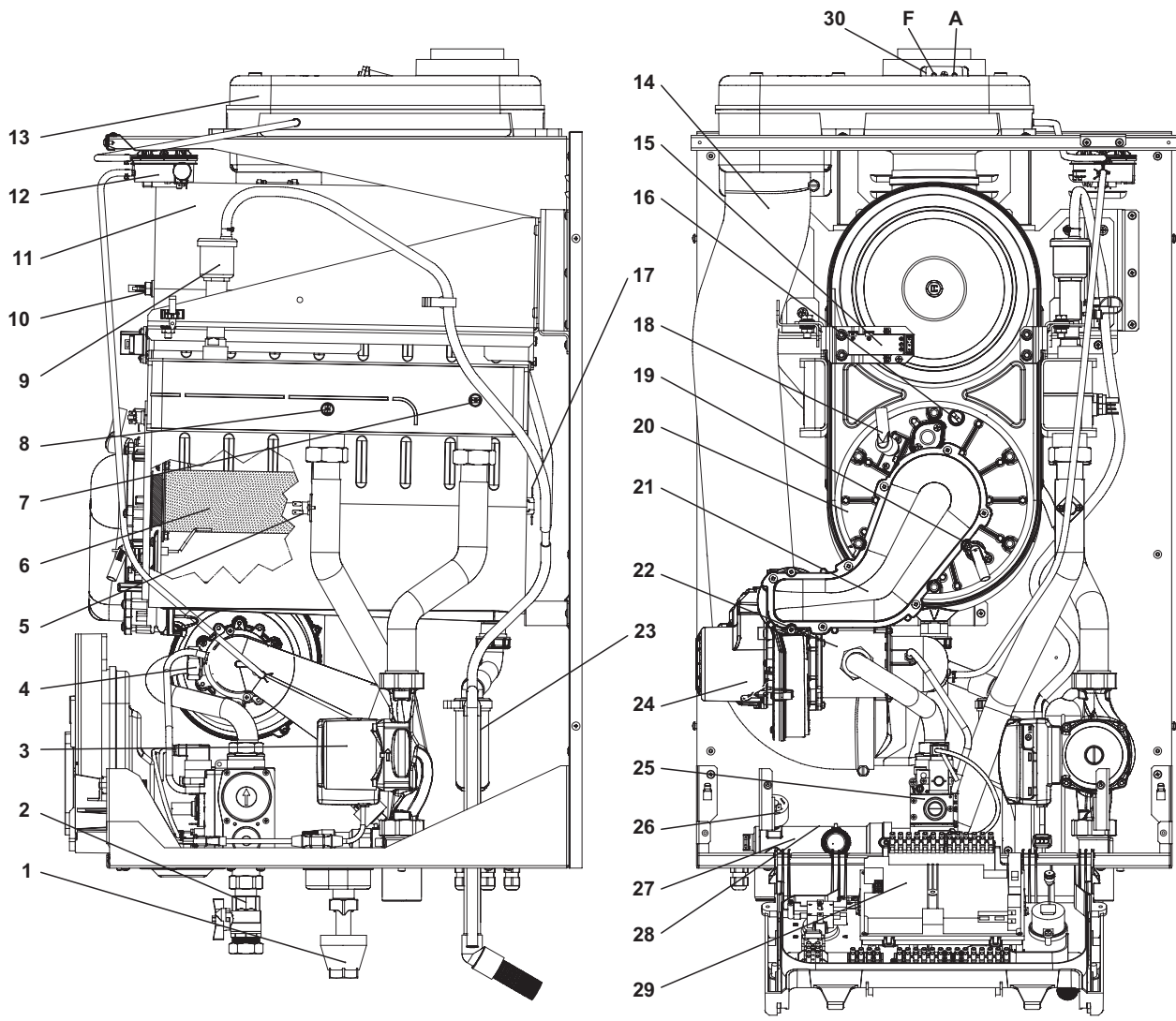

Right side

Front

- | | | | |
|----|---------------------------|----|------------------------------------|
| 1 | Tundish | 16 | Overheat thermostat (manual reset) |
| 2 | Gas cock | 17 | Heat exchanger thermal fuse |
| 3 | Pump | 18 | Ignition electrode |
| 4 | Injector | 19 | Flame detection electrode |
| 5 | Overheat thermostat | 20 | Combustion chamber front cover |
| 6 | Burner | 21 | Manifold cover |
| 7 | System return NTC | 22 | Venturi housing |
| 8 | System flow NTC | 23 | Condensate trap |
| 9 | Automatic air vent | 24 | Fan |
| 10 | Flue sensor | 25 | Gas valve |
| 11 | Condensing heat exchanger | 26 | Primary pressure switch |
| 12 | Air pressure switch | 27 | Flow manifold |
| 13 | Flue hood manifold | 28 | Safety valve 4 bar |
| 14 | Air intake pipe | 29 | PCB |
| 15 | Spark generator | 30 | Test points (air A) - (flue F) |

Fig. 7.5 Pro Tec Plus 70, 90, 115

8 WIRING DIAGRAM

Pro Tec Plus 50 model only Pro Tec Plus 70, 90, 115 models only

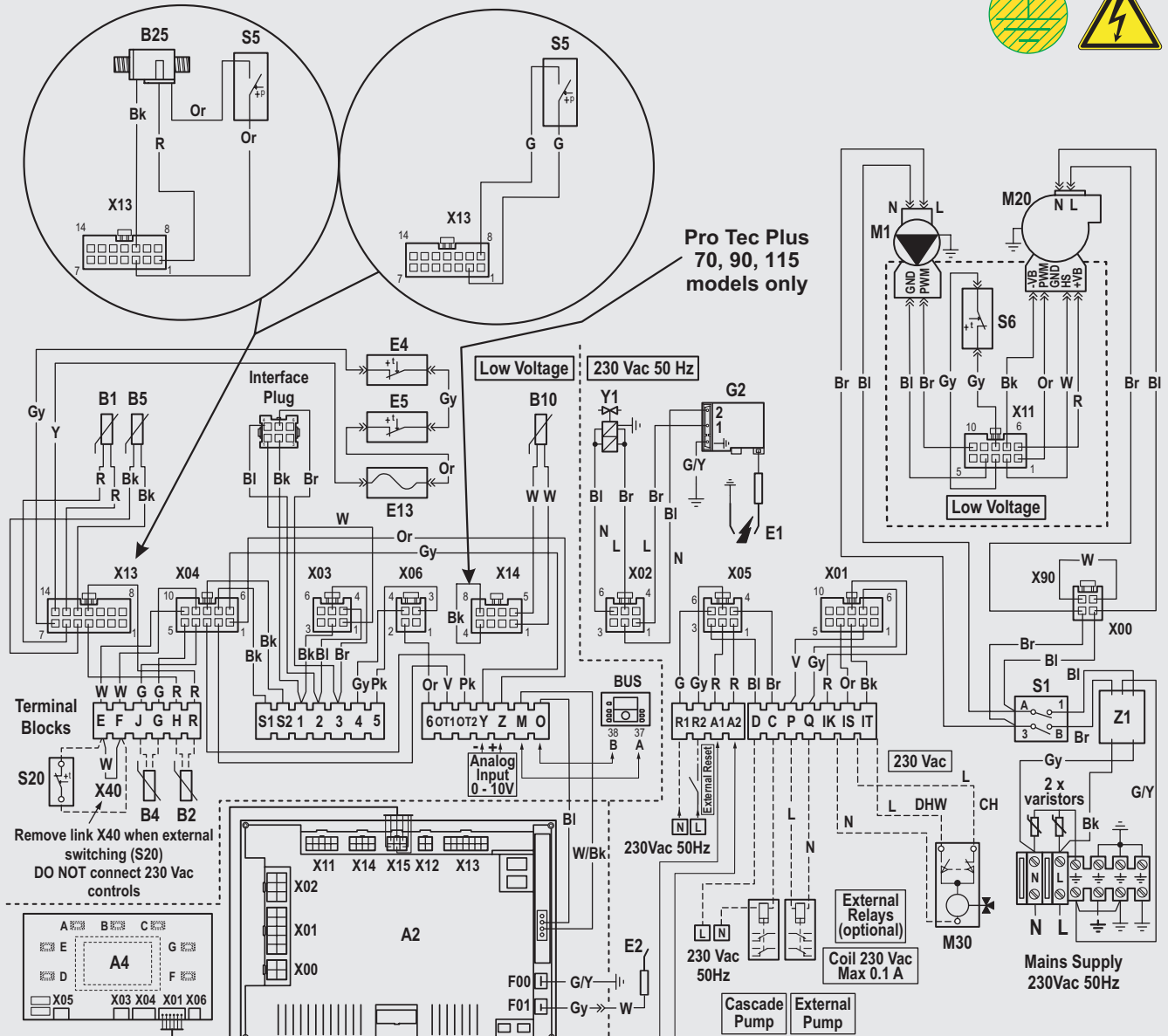

Component Key

- A2 PCB
- A4 Display board
- B1 Flow sensor
- B2 DHW sensor (optional)
- B4 External sensor (optional)
- B5 Return sensor
- B10 Flue sensor
- B25 Primary flow switch (50 model only)
- E1 Ignition electrode
- E2 Flame sensing electrode
- E4 Overheat thermostat
- E5 Overheat thermostat (manual reset)
- E13 Flue safety thermofuse
- G2 Spark generator
- M1 Boiler pump
- M30 3-way valve motor (optional)
- M20 Fan
- S1 Main switch
- S5 System pressure switch
- S6 Air pressure switch
- S20 Room thermostat (optional)
- X40 Factory fitted link
- X90 Configuration link (with or without air pressure switch)
- Y1 Gas valve
- Z1 Suppression filter

Alarm Free contact Max 0.8 A 230 Vac

Cascade pump (optional) will operate during CH function only
External pump (optional) will operate according to the boiler pump cycle i.e. CH and DHW operation

Colour Code

- Bk Black
- Bl Blue
- Br Brown
- G Green
- Gy Grey
- G/Y Green/Yellow
- Or Orange
- V Violet
- Pk Pink
- R Red
- W White
- W/Bk White/Black
- Y Yellow

WARNING:

ISOLATE ELECTRICAL SUPPLY BEFORE REMOVING ANY COVERS

Fig. 8.1

9 FAULT FINDING

The boiler will display any faults indicated by a flashing screen and code (Fig. 9.1).

There are different types of codes that can be divided up as follows:

'0Axx' for resettable faults. Before resetting the fault you will need to wait for the boiler to finish its post ventilation function, which lasts approximately 60 seconds.

'0Exx' and 'FExx' for non-resettable anomalies.

The 'xx' suffix stands for the fault code described in the following tables.

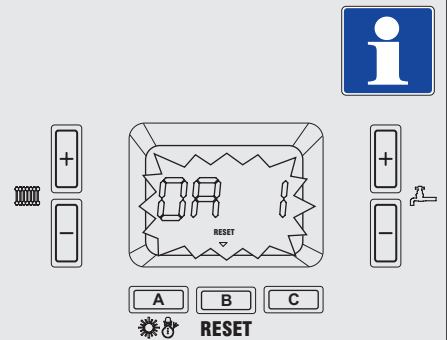

Fig. 9.1

Fault code	Fault description	Possible solutions
0A1	Ignition failure.	Check for correct gas supply (purged and valves open). Check ignition electrode position and spark. Check flame sensing electrode connections. Check gas valve operation.
0A2	Flame detection fault.	Check flame sensing electrode connections. Check for a short circuit to the electrode or wires.
0A3	Overheat thermostat lock-out. Relating to thermostats, thermal fuse, or manual reset thermostat.	Check for water circulation. Check for air in the heat exchanger. Check for system restrictions and blockages. Check overheat thermostat and connections. Reset overheat thermostat if required.
0A4	Air pressure switch fault	Check flue for blockage/restrictions. Check air pressure switch/connections. Check fan functions.
0A5	Fan speed fault.	Check flue and ventilation. Check air inlet manifold and pipe. Check for fan damage/fault. Check fan wire connections.
0A7	High flue temperature fault.	Check for air in the primary heat exchanger. Check for system restrictions causing overheating. Check the flue run for restrictions or blockages.
0A8	Flame circuit fault.	Check for correct gas supply (purged and valves open). Check ignition electrode position and spark. Check flame sensing electrode gap and connections.
0A9	Gas valve electrical error.	Check gas valve plug and wiring. Check main PCB. Check gas valve operation. Check for gas contamination.
0A15	Flow and return sensor anomaly detected. The sensor shows an incorrect temperature value	Check for poor or incorrect circulation. Check for external circuit influences. Check resistances of flow and return sensors.
0A18	Flow and return sensor anomaly detected. Sudden temperature change detected on the flow or return sensor.	Check system circulation. Check operation of zone valves. Check resistances and function of flow and return sensors.
0A21	Main PCB fault.	Check all electrical connections. Check for water ingress in connections.
0A30	Flow sensor short circuit.	Check flow sensor connections and wires. Check for water ingress in connections.
0A31	Flow sensor out of range. Sensor measures a temperature outside normal working range.	Check flow sensor connections and damaged wires. Check sensor resistance values.
0A37	Pro Tec 50 - Insufficient system flow. If the system flow is too low for a certain period, the boiler will switch off.	Check the flow switch reading P05. Check the system for restrictions or shut valves. Check pump function. Check system pressure.
	Pro Tec 70, 90, 115 - Insufficient system pressure. If the system pressure is too low the boiler switches off.	Check the system pressure is 1 - 2 bar. If necessary refill to the correct pressure.
0A43	Return sensor short circuit.	Check return sensor connections and wires. Check for water ingress in connections.
0A44	Return sensor out of range. Sensor measures a temperature outside normal working range.	Check return sensor connections and damaged wires. Check return sensor resistance values.
0A80	Flow and return sensor connection fault. Fault may occur after several minutes of boiler operation.	Check the wires are connected to the correct sensors.

Fault code	Fault description	Possible solutions
0E2	Flame sensing fault.	Check flame sensing electrode connections. Check for a short circuit to the electrode or wire.
0E13	Maximum number of resets reached. More than five reset attempts have been reached within 15 minutes.	Investigate initial fault code displayed. Switch the power supply Off/On to clear this code.
0E25	Main PCB fault.	Check all electrical connections. Check for water ingress in connections.
0E32	DHW sensor short circuit.	Check DHW sensor connections and wires. Check for water ingress in connections.
0E33	DHW sensor out of range. DHW sensor measures a temperature outside normal working range.	Check DHW sensor connections and damaged cables. Check DHW sensor resistance values.
0E34	Low power supply voltage.	Check electrical socket connections. Check external power supply. Check for possible power disruptions.
0E37	Insufficient system pressure (Pro Tec Plus 70, 90, 115) (or pressure and flow Pro Tec Plus 50)	Check the system for circulation and restrictions. Check system pressure and gauge. Check pressure switch and connections.
0E45	Flue sensor short circuit.	Check flue sensor connections and wires. Check for water ingress in connections.
0E46	Flue sensor out of range. Flue sensor measures a temperature outside normal working range.	Check flue sensor connections and wires. Check flue sensor resistance values.
0E81	Flow and return sensor anomaly detected. The sensor shows an incorrect temperature value.	Check for poor or incorrect circulation. Check for external circuit influences. Check resistances of flow and return sensors.
0E98	Simple cascade communication error.	Check 'M to O' connections. Check compatible software on PCB.
0E99	Simple cascade communication error.	Check wiring connections on all boilers. Check correct configuration, parameter 38.
FE94	Display PCB fault.	Check electrical connections to display board. Check for water ingress in connections. Check for damage to buttons or LCD screen.
FE95	External flow sensor out of range or short circuit. External flow sensor measures a temperature outside normal working range.	Check external flow sensor connections and damaged wires. Check external flow sensor resistance values between 5 and 0. Approximately 12 k Ω at 25°C / 2k Ω at 75°C
FE96	External sensor fault.	Check external sensor connections and wires. Check for water ingress in connections. Check boiler parameter settings are correct.
FE97	Boiler PCB configuration error. This may occur if the main PCB or display PCB is changed.	Check all electrical connections. Check for correct parameter settings on PCB. Press '-' CH button until 'AUTO' appears, then press and hold 'RESET' button until 'bu1' appears.
Red pump LED	Pump fault	There can be three possible causes for this anomaly 1. Low power supply voltage. When the minimum voltage is reached after about two seconds, the LED turns from red to green to red and the pump stops. Wait for the power supply voltage to rise. When the pump restarts the LED will turn green again with a delay of about one second Note: The flow rate decreases as the supply voltage decreases 2. Seized rotor. After about four seconds of the seized pump trying to start the LED turns from green to red. Carefully rotate the screw in the middle of the pump head to manually release the rotor. Circulation starts up immediately the rotor is freed and after about ten seconds the LED turns from red to green 3. Electrical fault. Pump, wiring or PCB fault. Check the indicated components

10 PROGRAMMING THE BOILER PCB

The boiler is supplied with the PCB configuration set according to the boiler model, however it is possible to adjust certain parameters according to the boiler and system configuration.



Note: These parameters should only be adjusted by an approved Alpha engineer or Agent.

To access the programming menu, press and hold buttons 'B' and 'C' simultaneously. The screen will display the letter P and a corresponding parameter number and then display the corresponding set value for that parameter. Scroll through the parameters by using the CH + and – buttons ('1' as shown in Fig. 10.1). To change a parameter value press the DHW + and – buttons ('2' as shown in Fig. 10.1) to the desired value.

The parameter value is stored by either moving to the next parameter or by pressing button 'B'.

Exit the parameter menu saving your new settings by pressing the buttons 'B' and 'C' simultaneously. The boiler will then run a self-diagnostics cycle displaying PARA and Auto on the screen.

Note: If the programming menu is not exited, the boiler will automatically exit the menu within approximately 2 minutes without saving any changes and running a self-diagnostics cycle displaying PARA and Auto on the screen.

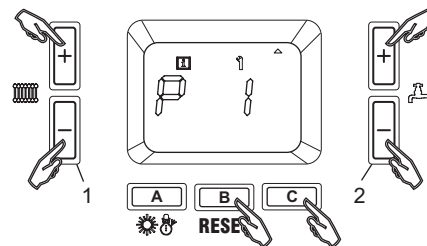

Fig. 10.1

Parameter Programming Menu				
Parameter	Feature	Description	Adjustment	Default value
P01	Set CH flow temp.	CH flow temp. range.	20 - P02 °C	85
P02	Set max. flow temp.	Max. flow temp.	20 - 95°C	85
P03	Heating hysteresis (cycling)	Flow temp. differential between cycling.	2 - 10°C	5
P04	Anti cycling time	Time delay between firing to avoid boiler cycling.	0 - 15 mins	3
P05	Stabalisation period	Initial stabalisation period at min. rate.	3 - 10 mins	3
P06	CH ramp up	Rate to ramp up the CH flow temp. (0 is no ramp up).	0 - 60°C/min	4
P07	Pump overrun	Pump overrun time after CH set temp. is achieved.	1 - 30 mins	3
P08	Max. heat power output	Output power according to max. available.	P09 - 100%	100
P09	Min. heat power output	Min. output setting.	0 - P08%	0
P10	Min. pump flow rate (Pro Tec Plus 50 only)	Min. flow rate to activate the boiler. Note: Do not adjust this parameter (Pro Tec Plus 50 only).	5 - 47 l/min	14
P11	Anti humidity setting	Fan speed setting for anti heat exchanger humidity cycle (0 = disabled, recommended value = 40).	P26 - 120 RPM x 50	0
P12	Cascade min. modulation	% level of minimum modulation when in simple cascade		10
P13	Boiler power value	Boiler power information value - software setting for boiler type.	0 - 255 kW	50 model = 50 70 model = 70 90 model = 90 115 model = 115
P14	External sensor setting	External sensor operating gradient, 0 is disabled.	0 - 10 (must be set at 0 when in cascade)	0
P15	External sensor offset	CH offset in relation to external sensor gradient P14.	20 - 70°C	30
P16	DHW set temp.	Set temp. for DHW when using boiler DHW function.	20 - 65°C	65
P17	DHW function	0 = diverter valve, 1 = DHW pump after a header	0 - 1	0
P18	DHW reheat temp.	Temp. differential to reheat DHW function from P16.	2 - 10°C	5
P19	DHW overrun cycle	Overrun time after DHW set temp. is achieved.	0 - 180 sec	60
P20	Max. DHW output power	Max. power available during DHW function.	P21 - 100%	50
P21	Min. DHW ouput power	Min. power available during DHW function.	0 - P20%	0

Parameter Programming Menu				
Parameter	Feature	Description	Adjustment	Default value
P22	DHW flow temp. (stat)	Flow temp. during DHW function when using external thermostat.	30 - 90°C	80
P23	DHW flow temp. (NTC)	Min. flow temp. during DHW function, this value is above DHW set temp. P16.	5 - 30°C	15
P24	DHW off set point time	Time to continue firing to avoid boiler cycling during DHW function when set value is achieved.	0 - 255 sec	60
P25	Max. fan speed	Set the max. fan speed - boiler max. output power.	P26 - 255 RPM x 50	50 model, NG=131, LPG=129 70 model, NG=124, LPG=122 90 model, NG=134, LPG=127 115 model, NG=140, LPG=140
P26	Min. fan speed	Set the min. fan speed - boiler min. output power.	0 - P25 RPM x 50	50 model, NG=22, LPG=21 70 model, NG=27, LPG=25 90 model, NG=26, LPG=25 115 model, NG=26, LPG=25
P27	Min. pump speed	Minimum pump speed (percentage). Do not set values lower than the default value.	1 - 100%	50 model = 77 70, 90, 115 models = 30
P28	Pump speed during ignition	Pump speed during startup (percentage). Do not set values lower than the default value.	1 - 100%	50 model = 77 70, 90, 115 models = 40
P29	DHW sensor mode	Used to select the DHW sensor mode between sensor and On/Off thermostat.	1 = NTC sensor 17 = On/Off thermostat	1
P30	Ignition fan speed	Fan speed during ignition function. Note: Do not adjust this parameter.	0 - 114 RPM x 50 (range limited by P25 and P26)	46
P31	Display units	Display units - imperial or metric.	0 - 127 = °C - kW 128 - 256 = °F - Btu/h	0
P32	CH min. set point	Limits the minimum CH temperature value	20 - 50°C	20
P33	Cascade frost level	Temperature to activate frost protection in cascade mode	2 - 20°C	5
P34	Cascade frost off	Off temperature for frost protection in cascade mode	2 - 20°C	15
P35	Cascade delay	Switch delay in cascade mode	0 - 255 sec	60
P36	Temp. sampling time	Time between temp. sampling intervals. Note: Do not adjust this parameter.	1 - 10 sec	3
P37	0 - 10 V output	0 - 10 V control feature (0 = temperature, 1 = heat output)	0 - 1	0
P38	External sensor fault	For cascade function (0 = none, 1 = fitted)	0 - 1	0

11 PERFORMANCE DATA

NOTE: The data provided in the following tables was obtained using 0.5 m concentric flue.
The number of revs for the fan on the display is expressed in revs / 50 (i.e. 1000 revs = 20).

Pro Tec Plus 50

Heat Output (kW)	Natural Gas (G20)		Propane (G31)	
	Burner Gas Flow Rate (m ³ /h)	Fan Revs (rpm)	Burner Gas Flow Rate (kg/h)	Fan Revs (rpm)
49.9	5.43	6550	3.98	6450
45.0	4.87	5910	3.57	5810
41.0	4.42	5410	3.25	5300
35.0	3.78	4670	2.77	4570
33.0	3.57	4430	2.62	4330
29.0	3.14	3960	2.31	3860
25.0	2.73	3490	2.00	3390

Pro Tec Plus 70

Heat Output (kW)	Natural Gas (G20)		Propane (G31)	
	Burner Gas Flow Rate (m ³ /h)	Fan Revs (rpm)	Burner Gas Flow Rate (kg/h)	Fan Revs (rpm)
68.0	7.40	6200	5.43	6100
60.0	6.52	5520	4.78	5390
54.0	5.86	5020	4.30	4880
50.0	5.43	4690	3.99	4550
44.0	4.79	4210	3.51	4060
40.0	4.36	3890	3.20	3740
34.0	3.71	3420	2.72	3270
30.0	3.28	3100	2.41	2960

Pro Tec Plus 90

Heat Output (kW)	Natural Gas (G20)		Propane (G31)	
	Burner Gas Flow Rate (m ³ /h)	Fan Revs (rpm)	Burner Gas Flow Rate (kg/h)	Fan Revs (rpm)
90.0	9.77	6700	7.17	6350
78.0	8.45	5780	6.20	5530
67.0	7.25	4980	5.32	4800
56.0	6.06	4210	4.45	4090
45.0	4.88	3480	3.58	3400

Pro Tec Plus 115

Heat Output (kW)	Natural Gas (G20)		Propane (G31)	
	Burner Gas Flow Rate (m ³ /h)	Fan Revs (rpm)	Burner Gas Flow Rate (kg/h)	Fan Revs (rpm)
111.0	12.07	7000	8.86	7000
104.0	11.30	6550	8.29	6530
97.0	10.53	6110	7.73	6070
90.0	9.76	5680	7.16	5620
83.0	9.00	5260	6.60	5190
76.0	8.24	4850	6.05	4760
69.0	7.48	4440	5.49	4350
62.0	6.72	4040	4.93	3940
55.0	5.97	3650	4.38	3550

12 CASCADE SYSTEM INSTALLATION

The Alpha Pro Tec Plus boilers can be cascaded together to increase output and versatility according to the building requirements. Cascade systems can vary in size and design with the option of up to five Pro Tec Plus boilers being connected using Alpha manifold kits and cascade flueing with a corresponding low loss header to suit. Additional controls are available to enable mixed and/or direct heating zones and a hot water zone (cylinder).

Alternatively a barrier heat exchanger can be used to separate the system from the boiler enabling connection to gravity or older heating circuits maintaining a clean pressurised circuit on the boilers.

When fitting multiple boilers on a combined flue system, all boilers must have a non-return valve fitted.

Refer to Alpha Technical for further options and guidance - 0344 8718764

- F - Heating flow
- SV - Safety valve outlet
- G - Gas supply
- CD - Condensate drain
- R - Heating return

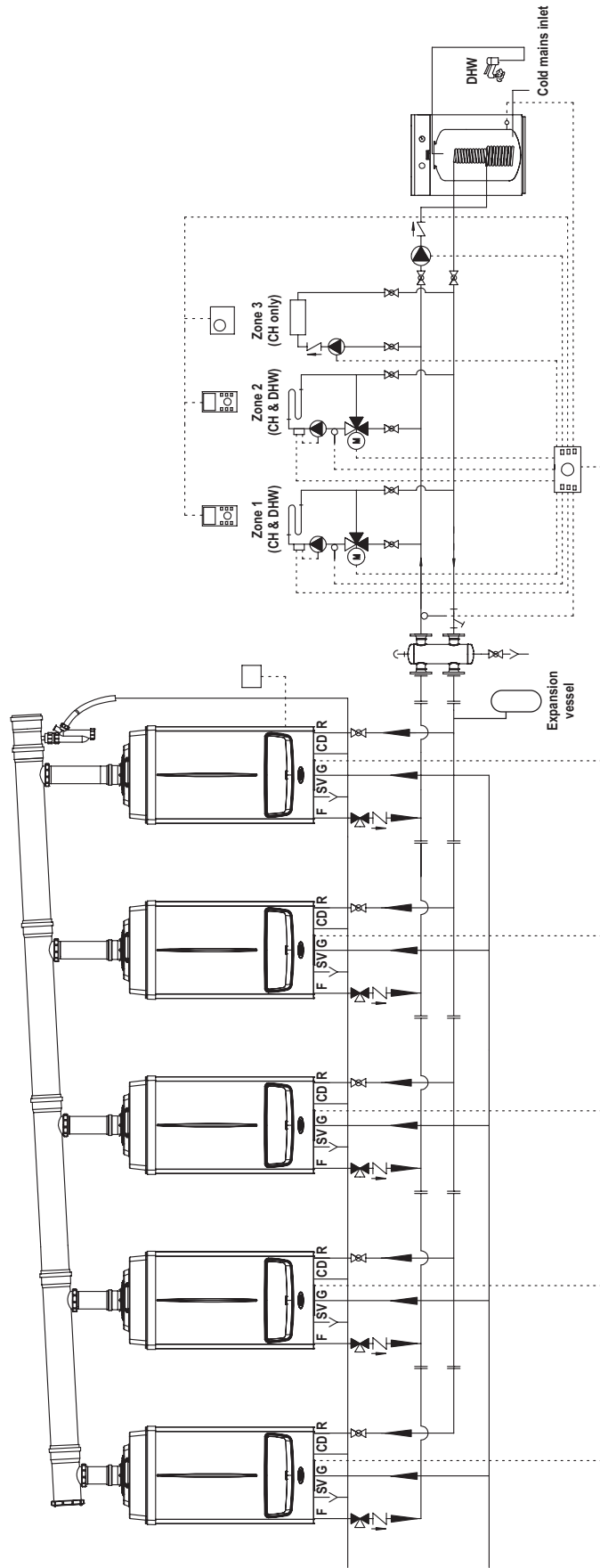

13 SHORT PARTS LIST

Description	Qty.	Alpha Pt. No.
Main PCB	1	1.033969
Display PCB	1	1.033971
Pressure gauge	1	1.035335
Flame sensing electrode	1	3.022326
Ignition electrode	1	1.028702
Burner - Pro Tec Plus 50	1	1.038783
Burner - Pro Tec Plus 70	1	1.041112
Burner - Pro Tec Plus 90	1	1.040164
Burner - Pro Tec Plus 115	1	1.040682
Fan - Pro Tec Plus 50	1	3.026243
Fan - Pro Tec Plus 70	1	3.026244
Fan - Pro Tec Plus 90, 115	1	3.026245
Flexible air intake pipe - Pro Tec Plus 50	1	1.036647
Flexible air intake pipe - Pro Tec Plus 70, 90, 115	1	1.035180
Flue hood manifold - Pro Tec Plus 50	1	3.029190
Flue hood manifold - Pro Tec Plus 70, 90, 115	1	3.029191
Flow / return NTC	1	1.023435
Pump - Pro Tec Plus 50	1	1.039695
Pump - Pro Tec Plus 70	1	1.034021
Pump - Pro Tec Plus 90, 115	1	1.038000
Automatic air vent - Pro Tec Plus 50	2	1.015436
Automatic air vent - Pro Tec Plus 70, 90, 115	1	1.2295
Primary pressure switch	1	1.018320
Primary flow switch - Pro Tec Plus 50	1	1.035966
Gas valve - Pro Tec Plus 50, 70	1	1.018472
Gas valve - Pro Tec Plus 90, 115	1	1.033996
Safety valve (4 bar)	1	3.024264
Overheat thermostat	1	1.016870
Overheat thermostat - manual reset	1	1.037212
Flue sensor - Pro Tec Plus 50	1	1.034101
Flue sensor - Pro Tec Plus 70, 90, 115	1	1.028832
Condensate trap	1	1.035733
Cascade address unit	1	1.034983
Spark generator	1	1.035601
Wall mounting hook	2	2.010615
Test point cover unit	1	1.025278
Wall fixing kit (hooks, screws, plugs)	1	3.019353
Hydraulic circuit seal kit	1	3.025041
Air intake and flue circuit seal kit	1	3.025042
Gas circuit seal kit	1	3.025043
Heat exchanger seal kit	1	3.025044
Complete boiler seal kit	1	3.025045
Ignition electrode lead	1	1.035386
Air pressure switch - Pro Tec Plus 50, 90, 115	1	1.041722
Air pressure switch - Pro Tec Plus 70	1	1.041723

14 ENERGY CLASSIFICATION

14.1 TECHNICAL PARAMETERS FOR MIXED BOILERS (IN COMPLIANCE WITH REGULATION 813/2013)

The values in the following tables refer to the maximum heating output.

Model(s):				Pro Tec Plus 50				
Condensing boiler:				YES				
Low-temperature boiler:				NO				
B1 boiler:				NO				
Cogeneration space heater:				NO			Equipped with a supplementary heater:	NO
Combination heater:				NO				
Item	Symbol	Value	Unit	Item	Symbol	Value	Unit	
Rated heat output	P_n	50	kW	Seasonal space heating energy efficiency	η_s	92	%	
For boiler space heaters and boiler combination heaters: useful heat output				For boiler space heaters and boiler combination heaters: Useful efficiency				
At rated heat output and high temperature regime (*)	P_4	49.9	kW	At rated heat output and high temperature regime (*)	η_4	87.7	%	
At 30% of rated heat output and low temperature regime (**)	P_1	15.0	kW	At 30% of rated heat output and low temperature regime (**)	η_1	96.4	%	
Auxiliary electricity consumption				Other items				
At full load	$e_{l_{max}}$	0.091	kW	Standby heat loss	P_{stby}	0.091	kW	
At part load	$e_{l_{min}}$	0.018	kW	Ignition burner power consumption	P_{ign}	0.00	kW	
In standby mode	P_{SB}	0.006	kW	Emissions of nitrogen oxides	NO_x	36	mg / kWh	
For combination heaters:								
Declared load profile				Water heating energy efficiency				
				η_{WH}				
Daily electricity consumption				Daily fuel consumption				
Q_{elec}				Q_{fuel}				
Contact details								
Alpha Therm Ltd., Nepicar House, Wrotham Heath, Kent. TN15 7RS								
(*) High temperature regime means 60°C return temperature at heater inlet and 80°C feed temperature at heater outlet.								
(**) Low temperature means for condensing boilers 30°C, for low-temperature boilers 37°C and for other heaters 50°C return temperature.								

Model(s):				Pro Tec Plus 70				
Condensing boiler:				YES				
Low-temperature boiler:				NO				
B1 boiler:				NO				
Cogeneration space heater:				NO			Equipped with a supplementary heater:	NO
Combination heater:				NO				
Item	Symbol	Value	Unit	Item	Symbol	Value	Unit	
Rated heat output	P_n	68	kW	Seasonal space heating energy efficiency	η_s	92	%	
For boiler space heaters and boiler combination heaters: useful heat output				For boiler space heaters and boiler combination heaters: Useful efficiency				
At rated heat output and high temperature regime (*)	P_4	68.0	kW	At rated heat output and high temperature regime (*)	η_4	87.7	%	
At 30% of rated heat output and low temperature regime (**)	P_1	20.4	kW	At 30% of rated heat output and low temperature regime (**)	η_1	96.6	%	
Auxiliary electricity consumption				Other items				
At full load	$e_{l_{max}}$	0.098	kW	Standby heat loss	P_{stby}	0.143	kW	
At part load	$e_{l_{min}}$	0.028	kW	Ignition burner power consumption	P_{ign}	0.00	kW	
In standby mode	P_{SB}	0.004	kW	Emissions of nitrogen oxides	NO_x	22	mg / kWh	
For combination heaters:								
Declared load profile				Water heating energy efficiency				
				η_{WH}				
Daily electricity consumption				Daily fuel consumption				
Q_{elec}				Q_{fuel}				
Contact details								
Alpha Therm Ltd., Nepicar House, Wrotham Heath, Kent. TN15 7RS								
(*) High temperature regime means 60°C return temperature at heater inlet and 80°C feed temperature at heater outlet.								
(**) Low temperature means for condensing boilers 30°C, for low-temperature boilers 37°C and for other heaters 50°C return temperature.								

The values in the following tables refer to the maximum heating output.

Model(s):				Pro Tec Plus 90				
Condensing boiler:				YES				
Low-temperature boiler:				NO				
B1 boiler:				NO				
Cogeneration space heater:				NO			Equipped with a supplementary heater:	NO
Combination heater:				NO				
Item	Symbol	Value	Unit	Item	Symbol	Value	Unit	
Rated heat output	P_n	90	kW	Seasonal space heating energy efficiency	η_s	92	%	
For boiler space heaters and boiler combination heaters: useful heat output				For boiler space heaters and boiler combination heaters: Useful efficiency				
At rated heat output and high temperature regime (*)	P_4	90.0	kW	At rated heat output and high temperature regime (*)	η_4	87.8	%	
At 30% of rated heat output and low temperature regime (**)	P_1	27.0	kW	At 30% of rated heat output and low temperature regime (**)	η_1	97.1	%	
Auxiliary electricity consumption				Other items				
At full load	$e_{l_{max}}$	0.143	kW	Standby heat loss	P_{stby}	0.145	kW	
At part load	$e_{l_{min}}$	0.021	kW	Ignition burner power consumption	P_{ign}	0.00	kW	
In standby mode	P_{SB}	0.005	kW	Emissions of nitrogen oxides	NO_x	18	mg / kWh	
For combination heaters:								
Declared load profile				Water heating energy efficiency				
				η_{WH}				
Daily electricity consumption				Daily fuel consumption				
Q_{elec}				Q_{fuel}				
Contact details				Alpha Therm Ltd., Nepicar House, Wrotham Heath, Kent. TN15 7RS				
(*) High temperature regime means 60°C return temperature at heater inlet and 80°C feed temperature at heater outlet.								
(**) Low temperature means for condensing boilers 30°C, for low-temperature boilers 37°C and for other heaters 50°C return temperature.								

Model(s):				Pro Tec Plus 115				
Condensing boiler:				YES				
Low-temperature boiler:				NO				
B1 boiler:				NO				
Cogeneration space heater:				NO			Equipped with a supplementary heater:	NO
Combination heater:				NO				
Item	Symbol	Value	Unit	Item	Symbol	Value	Unit	
Rated heat output	P_n	111	kW	Seasonal space heating energy efficiency	η_s	92	%	
For boiler space heaters and boiler combination heaters: useful heat output				For boiler space heaters and boiler combination heaters: Useful efficiency				
At rated heat output and high temperature regime (*)	P_4	111.0	kW	At rated heat output and high temperature regime (*)	η_4	87.7	%	
At 30% of rated heat output and low temperature regime (**)	P_1	33.3	kW	At 30% of rated heat output and low temperature regime (**)	η_1	96.9	%	
Auxiliary electricity consumption				Other items				
At full load	$e_{l_{max}}$	0.190	kW	Standby heat loss	P_{stby}	0.168	kW	
At part load	$e_{l_{min}}$	0.025	kW	Ignition burner power consumption	P_{ign}	0.00	kW	
In standby mode	P_{SB}	0.004	kW	Emissions of nitrogen oxides	NO_x	28	mg / kWh	
For combination heaters:								
Declared load profile				Water heating energy efficiency				
				η_{WH}				
Daily electricity consumption				Daily fuel consumption				
Q_{elec}				Q_{fuel}				
Contact details				Alpha Therm Ltd., Nepicar House, Wrotham Heath, Kent. TN15 7RS				
(*) High temperature regime means 60°C return temperature at heater inlet and 80°C feed temperature at heater outlet.								
(**) Low temperature means for condensing boilers 30°C, for low-temperature boilers 37°C and for other heaters 50°C return temperature.								

14.2 PRODUCT DATA SHEET (IN COMPLIANCE WITH REGULATION 811/2013)

Pro Tec Plus 50

Pro Tec Plus 70

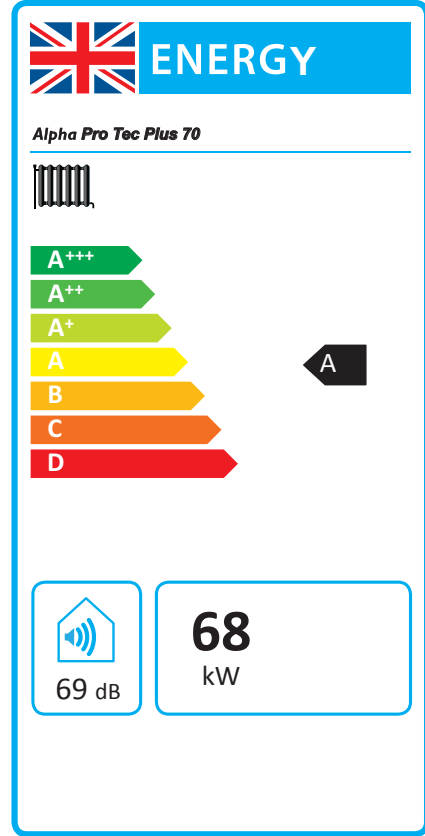
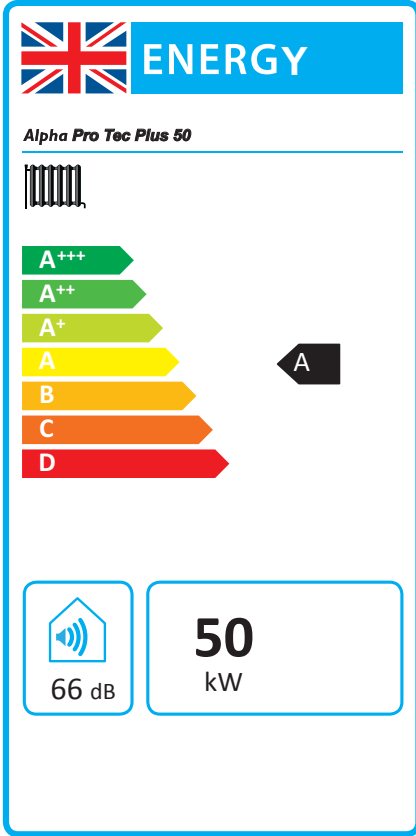

Parameter	value
Yearly energy consumption for the heating function (QHE)	157.0 GJ
Yearly electricity consumption for the domestic hot water function (AEC)	-----
Yearly fuel consumption for the domestic hot water function (AFC)	-----
Seasonal room heating yield (η_s)	92 %
Domestic hot water production yield (η_{wh})	-----

Parameter	value
Yearly energy consumption for the heating function (QHE)	213.5 GJ
Yearly electricity consumption for the domestic hot water function (AEC)	-----
Yearly fuel consumption for the domestic hot water function (AFC)	-----
Seasonal room heating yield (η_s)	92 %
Domestic hot water production yield (η_{wh})	-----

14.3 FACSIMILE FOR FILLING IN ROOM HEATING SYSTEM ASSEMBLY CHART

Seasonal space heating energy efficiency of boiler	1 'I' %																														
Temperature control From fiche of temperature control	<div style="border: 1px solid black; padding: 5px; display: inline-block; margin-bottom: 5px;"> Class I = 1 %, Class II = 2 %, Class III = 1.5 %, Class IV = 2 %, Class V = 3 %, Class VI = 4 %, Class VII = 3.5 %, Class VIII = 5 % </div> + 2 %																														
Supplementary boiler From fiche of boiler	<div style="border: 1px solid black; padding: 5px; display: inline-block; margin-bottom: 5px;"> Seasonal space heating energy efficiency (in %) </div> $(\text{ } - \text{'I'}) \times 0,1 = \pm \text{ } \%$																														
<i>Solar contribution</i> From fiche of solar device	<div style="display: flex; justify-content: space-between; align-items: flex-start;"> <div style="border: 1px solid black; padding: 2px; font-size: 8px;">Collector size (in m²)</div> <div style="border: 1px solid black; padding: 2px; font-size: 8px;">Tank volume (in m³)</div> <div style="border: 1px solid black; padding: 2px; font-size: 8px;">Collector efficiency (in %)</div> <div style="border: 1px solid black; padding: 2px; font-size: 8px;"> Tank rating A* = 0.95, A = 0.91 B = 0.86, C = 0.83 D-G = 0.81 </div> </div> $(\text{'III'} \times \text{ } + \text{'IV'} \times \text{ }) \times (0.9 \times \text{ } / 100) \times \text{ } = + \text{ } \%$																														
Supplementary heat pump From fiche of heat pump	<div style="border: 1px solid black; padding: 5px; display: inline-block; margin-bottom: 5px;"> Seasonal space heating energy efficiency (in %) </div> $(\text{ } - \text{'I'}) \times \text{'II'} = + \text{ } \%$																														
Solar contribution AND Supplementary heat pump	Select smaller value $0.5 \times \text{ } \text{ O } 0.5 \times \text{ } = - \text{ } \%$																														
Seasonal space heating energy efficiency of package	7 %																														
Seasonal space heating energy efficiency class of package	<div style="border: 1px solid black; padding: 10px; text-align: center;"> <table style="margin: auto; border-collapse: collapse;"> <tr> <td style="border: 1px solid black; width: 20px; height: 20px; margin: 2px;"></td> <td style="border: 1px solid black; width: 20px; height: 20px; margin: 2px;"></td> <td style="border: 1px solid black; width: 20px; height: 20px; margin: 2px;"></td> <td style="border: 1px solid black; width: 20px; height: 20px; margin: 2px;"></td> <td style="border: 1px solid black; width: 20px; height: 20px; margin: 2px;"></td> <td style="border: 1px solid black; width: 20px; height: 20px; margin: 2px;"></td> <td style="border: 1px solid black; width: 20px; height: 20px; margin: 2px;"></td> <td style="border: 1px solid black; width: 20px; height: 20px; margin: 2px;"></td> <td style="border: 1px solid black; width: 20px; height: 20px; margin: 2px;"></td> <td style="border: 1px solid black; width: 20px; height: 20px; margin: 2px;"></td> </tr> <tr> <td style="font-weight: bold; font-size: 1.2em;">G</td> <td style="font-weight: bold; font-size: 1.2em;">F</td> <td style="font-weight: bold; font-size: 1.2em;">E</td> <td style="font-weight: bold; font-size: 1.2em;">D</td> <td style="font-weight: bold; font-size: 1.2em;">C</td> <td style="font-weight: bold; font-size: 1.2em;">B</td> <td style="font-weight: bold; font-size: 1.2em;">A</td> <td style="font-weight: bold; font-size: 1.2em;">A⁺</td> <td style="font-weight: bold; font-size: 1.2em;">A⁺⁺</td> <td style="font-weight: bold; font-size: 1.2em;">A⁺⁺⁺</td> </tr> <tr> <td style="font-size: 0.8em;">< 30 %</td> <td style="font-size: 0.8em;">≥ 30 %</td> <td style="font-size: 0.8em;">≥ 34 %</td> <td style="font-size: 0.8em;">≥ 36 %</td> <td style="font-size: 0.8em;">≥ 75 %</td> <td style="font-size: 0.8em;">≥ 82 %</td> <td style="font-size: 0.8em;">≥ 90 %</td> <td style="font-size: 0.8em;">≥ 98 %</td> <td style="font-size: 0.8em;">≥ 125 %</td> <td style="font-size: 0.8em;">≥ 150 %</td> </tr> </table> </div>											G	F	E	D	C	B	A	A ⁺	A ⁺⁺	A ⁺⁺⁺	< 30 %	≥ 30 %	≥ 34 %	≥ 36 %	≥ 75 %	≥ 82 %	≥ 90 %	≥ 98 %	≥ 125 %	≥ 150 %
G	F	E	D	C	B	A	A ⁺	A ⁺⁺	A ⁺⁺⁺																						
< 30 %	≥ 30 %	≥ 34 %	≥ 36 %	≥ 75 %	≥ 82 %	≥ 90 %	≥ 98 %	≥ 125 %	≥ 150 %																						
Boiler and supplementary heat pump installed with low temperature heat emitters at 35°C?	From fiche of heat pump 7 + (50 x 'II') = %																														
<i>The energy efficiency of the package of products provided for in this fiche may not correspond to its actual energy efficiency once installed in a building, as the efficiency is influenced by further factors such as heat loss in the distribution system and the dimensioning of the products in relation to building size and characteristics.</i>																															

14.4 ROOM HEATING SYSTEM ASSEMBLY CHART

Seasonal space heating energy efficiency of boiler ① %

Temperature control
From fiche of temperature control ② %

Class I = 1 %, Class II = 2 %,
 Class III = 1.5 %, Class IV = 2 %,
 Class V = 3 %, Class VI = 4 %,
 Class VII = 3.5 %, Class VIII = 5 %

Supplementary boiler
From fiche of boiler ③ %

Seasonal space heating energy efficiency (in %)

$$(\text{ } - \text{ }) \times 0,1 = \pm \text{ } \%$$

Solar contribution
From fiche of solar device ④ %

Collector size (in m²)

Tank volume (in m³)

Collector efficiency (in %)

Tank rating
 A* = 0.95, A = 0.91
 B = 0.86, C = 0.83
 D-G = 0.81

$$(\text{ } \times \text{ } + \text{ } \times \text{ }) \times (0,9 \times (\text{ } / 100) \times \text{ } = + \text{ } \%$$

Supplementary heat pump
From fiche of heat pump ⑤ %

Seasonal space heating energy efficiency (in %)

$$(\text{ } - \text{ }) \times \text{ } = + \text{ } \%$$

Solar contribution AND Supplementary heat pump
Select smaller value ⑥ %

$$0.5 \times \text{ } \text{ O } 0.5 \times \text{ } = - \text{ } \%$$

Seasonal space heating energy efficiency of package ⑦ %

Seasonal space heating energy efficiency class of package

G	F	E	D	C	B	A	A⁺	A⁺⁺	A⁺⁺⁺		
< 30 %		≥ 30 %		≥ 34 %		≥ 36 %		≥ 75 %		≥ 82 %	
≥ 90 %			≥ 98 %			≥ 125 %			≥ 150 %		

Boiler and supplementary heat pump installed with low temperature heat emitters at 35°C?

From fiche of heat pump ⑦ %

$$\text{ } + (50 \times \text{ }) = \text{ } \%$$

The energy efficiency of the package of products provided for in this fiche may not correspond to its actual energy efficiency once installed in a building, as the efficiency is influenced by further factors such as heat loss in the distribution system and the dimensioning of the products in relation to building size and characteristics.

14.5 PARAMETERS FOR FILLING IN ASSEMBLY CHART

Parameter	Pro Tec Plus 50	Pro Tec Plus 70
'I'	92	92
'II'	*	*
'III'	0.53	0.39
'IV'	0.21	0.15

* To be established by means of table 5 of Regulation 811/2013 in case of "assembly" including a heat pump to integrate the boiler. In this case the boiler must be considered as the main appliance of the assembly.

14.6 DOMESTIC HOT WATER PRODUCTION SYSTEM ASSEMBLY CHART

Water heating energy efficiency of combination heater ① %

Declared load profile:

Solar contribution
From fiche of solar device

Auxiliary electricity
↓

(1.1 x - 10 %) x - = + ② %

Water heating energy efficiency of package under average climate ③ %

Water heating energy efficiency class of package under average climate

	<input type="checkbox"/>	<input type="checkbox"/>	<input type="checkbox"/>	<input type="checkbox"/>	<input type="checkbox"/>	<input type="checkbox"/>	<input type="checkbox"/>	<input type="checkbox"/>	<input type="checkbox"/>	<input type="checkbox"/>
	G	F	E	D	C	B	A	A⁺	A⁺⁺	A⁺⁺⁺
<input type="checkbox"/> M	< 27 %	≥ 27 %	≥ 30 %	≥ 33 %	≥ 36 %	≥ 39 %	≥ 65 %	≥ 100 %	≥ 130 %	≥ 163 %
<input type="checkbox"/> L	< 27 %	≥ 27 %	≥ 30 %	≥ 34 %	≥ 37 %	≥ 50 %	≥ 75 %	≥ 115 %	≥ 150 %	≥ 188 %
<input type="checkbox"/> XL	< 27 %	≥ 27 %	≥ 30 %	≥ 35 %	≥ 38 %	≥ 55 %	≥ 80 %	≥ 123 %	≥ 160 %	≥ 200 %
<input type="checkbox"/> XXL	< 28 %	≥ 28 %	≥ 32 %	≥ 36 %	≥ 40 %	≥ 60 %	≥ 85 %	≥ 131 %	≥ 170 %	≥ 213 %

Water heating energy efficiency under colder and warmer climate conditions

Colder: ③ - 0.2 x ② = %

Warmer : ③ + 0.4 x ② = %

The energy efficiency of the package of products provided for in this fiche may not correspond to its actual energy efficiency once installed in a building, as the efficiency is influenced by further factors such as heat loss in the distribution system and the dimensioning of the products in relation to building size and characteristics.

14.7 PARAMETERS FOR FILLING IN DHW PACKAGE ASSEMBLY CHART

Parameter	Pro Tec Plus 50	Pro Tec Plus 70
'I'	---	---
'II'	---	---
'III'	---	---
'IV'	---	---

* To be determined according to Regulation 811/2013 and transient calculation methods as per Notice of the European Community no. 207/2014.



GAS BOILER SYSTEM COMMISSIONING CHECKLIST

This Commissioning Checklist is to be completed in full by the competent person who commissioned the boiler as a means of demonstrating compliance with the appropriate Building Regulations and then handed to the customer to keep for future reference.

Failure to install and commission according to the manufacturer's instructions and complete this Benchmark Commissioning Checklist will invalidate the warranty. This does not affect the customer's statutory rights.

Customer name:	Telephone number:
Address:	
Boiler make and model:	
Boiler serial number:	
Commissioned by (PRINT NAME):	Gas Safe register number:
Company name:	Telephone number:
Company address:	
Commissioning date:	

To be completed by the customer on receipt of a Building Regulations Compliance Certificate*

Building Regulations Notification Number (if applicable):

CONTROLS (tick the appropriate boxes)

Time and temperature control to heating	Room thermostat and programmer/timer		Programmable room thermostat	
	Load/weather compensation		Optimum start control	
Time and temperature control to hot water	Cylinder thermostat and programmer/timer		Combination Boiler	
Heating zone valves	Fitted		Not required	
Hot water zone valves	Fitted		Not required	
Thermostatic radiator valves	Fitted		Not required	
Automatic bypass to system	Fitted		Not required	
Boiler interlock			Provided	

ALL SYSTEMS

The system has been flushed and cleaned in accordance with BS7593 and boiler manufacturer's instructions		Yes	
What system cleaner was used?			
What inhibitor was used?	Quantity		litres
Has a primary water system filter been installed?	Yes		No

CENTRAL HEATING MODE measure and record:

Gas rate	m ³ /hr	OR	ft ³ /hr
Burner operating pressure (if applicable)	mbar	OR Gas inlet pressure	mbar
Central heating flow temperature			°C
Central heating return temperature			°C

COMBINATION BOILERS ONLY

Is the installation in a hard water area (above 200ppm)?	Yes		No	
If yes, and if required by the manufacturer, has a water scale reducer been fitted?	Yes		No	
What type of scale reducer has been fitted?				

DOMESTIC HOT WATER MODE Measure and Record:

Gas rate	m ³ /hr	OR	ft ³ /hr
Burner operating pressure (at maximum rate)	mbar	OR Gas inlet pressure at maximum rate	mbar
Cold water inlet temperature			°C
Hot water has been checked at all outlets	Yes		Temperature °C
Water flow rate			l/min

CONDENSING BOILERS ONLY

The condensate drain has been installed in accordance with the manufacturer's instructions and/or BS5546/BS6798		Yes	
---	--	-----	--

ALL INSTALLATIONS

Record the following:	At max. rate:	CO	ppm	AND	CO/CO ₂	Ratio	
	At min. rate: (where possible)	CO	ppm	AND	CO/CO ₂	Ratio	
The heating and hot water system complies with the appropriate Building Regulations							Yes
The boiler and associated products have been installed and commissioned in accordance with the manufacturer's instructions							Yes
The operation of the boiler and system controls have been demonstrated to and understood by the customer							Yes
The manufacturer's literature, including Benchmark Checklist and Service Record, has been explained and left with the customer							Yes

Commissioning Engineer's Signature	
Customer's Signature	
(To confirm satisfactory demonstration and receipt of manufacturer's literature)	

*All installations in England and Wales must be notified to Local Authority Building Control (LABC) either directly or through a Competent Persons Scheme. A Building Regulations Compliance Certificate will then be issued to the customer.



SERVICE RECORD

It is recommended that your heating system is serviced regularly and that the appropriate Service Interval Record is completed.

Service Provider

Before completing the appropriate Service Record below, please ensure you have carried out the service as described in the manufacturer's instructions. Always use the manufacturer's specified spare part when replacing controls.

SERVICE 01					Date:
Engineer name:					
Company name:					
Telephone No:					
Gas safe register No:					
Record:	At max. rate:	CO	ppm	AND	CO ₂ %
	At min. rate: (Where Possible)	CO	ppm	AND	CO ₂ %
Comments:					
Signature					

SERVICE 02					Date:
Engineer name:					
Company name:					
Telephone No:					
Gas safe register No:					
Record:	At max. rate:	CO	ppm	AND	CO ₂ %
	At min. rate: (Where Possible)	CO	ppm	AND	CO ₂ %
Comments:					
Signature					

SERVICE 03					Date:
Engineer name:					
Company name:					
Telephone No:					
Gas safe register No:					
Record:	At max. rate:	CO	ppm	AND	CO ₂ %
	At min. rate: (Where Possible)	CO	ppm	AND	CO ₂ %
Comments:					
Signature					

SERVICE 04					Date:
Engineer name:					
Company name:					
Telephone No:					
Gas safe register No:					
Record:	At max. rate:	CO	ppm	AND	CO ₂ %
	At min. rate: (Where Possible)	CO	ppm	AND	CO ₂ %
Comments:					
Signature					

SERVICE 05					Date:
Engineer name:					
Company name:					
Telephone No:					
Gas safe register No:					
Record:	At max. rate:	CO	ppm	AND	CO ₂ %
	At min. rate: (Where Possible)	CO	ppm	AND	CO ₂ %
Comments:					
Signature					

SERVICE 06					Date:
Engineer name:					
Company name:					
Telephone No:					
Gas safe register No:					
Record:	At max. rate:	CO	ppm	AND	CO ₂ %
	At min. rate: (Where Possible)	CO	ppm	AND	CO ₂ %
Comments:					
Signature					

SERVICE 07					Date:
Engineer name:					
Company name:					
Telephone No:					
Gas safe register No:					
Record:	At max. rate:	CO	ppm	AND	CO ₂ %
	At min. rate: (Where Possible)	CO	ppm	AND	CO ₂ %
Comments:					
Signature					

SERVICE 08					Date:
Engineer name:					
Company name:					
Telephone No:					
Gas safe register No:					
Record:	At max. rate:	CO	ppm	AND	CO ₂ %
	At min. rate: (Where Possible)	CO	ppm	AND	CO ₂ %
Comments:					
Signature					

SERVICE 09					Date:
Engineer name:					
Company name:					
Telephone No:					
Gas safe register No:					
Record:	At max. rate:	CO	ppm	AND	CO ₂ %
	At min. rate: (Where Possible)	CO	ppm	AND	CO ₂ %
Comments:					
Signature					

SERVICE 10					Date:
Engineer name:					
Company name:					
Telephone No:					
Gas safe register No:					
Record:	At max. rate:	CO	ppm	AND	CO ₂ %
	At min. rate: (Where Possible)	CO	ppm	AND	CO ₂ %
Comments:					
Signature					

*All installations in England and Wales must be notified to Local Authority Building Control (LABC) either directly or through a Competent Persons Scheme. A Building Regulations Compliance Certificate will then be issued to the customer.



Alpha

HEATING INNOVATION

Alpha Therm Limited.
Nepicar House, London Road, Wrotham Heath,
Sevenoaks, Kent TN15 7RS
Tel: 0344 871 8764

email: info@alpha-innovation.co.uk
website: www.alpha-innovation.co.uk

*These instructions have been carefully prepared but we reserve the right to alter the specification at any time in the interest of product improvement.
© Alpha Therm Limited 2021.*

Part No. 1.043480 rev. ST.004218/003