

---

# KESTON

---

## 30C

### Installation and Servicing Instructions

FAN POWERED HIGH EFFICIENCY  
MODULATING DOMESTIC CONDENSING  
GAS COMBINATION BOILER

CE/PI No. 86-CL-38  
GC No. 47-930-03



---

# KESTON

---

## Boilers

CE

These instructions must be left either with the user or next to the site gas meter.

34 West Common Road  
Hayes, Bromley, Kent, BR2 7BX  
Tel. +44 (0) 20 8462 0262 Fax. +44 (0) 20 8462 4459  
email : [info@keston.co.uk](mailto:info@keston.co.uk) web : [www.keston.co.uk](http://www.keston.co.uk)  
COMPLIANT WITH BUILDING REGULATION PART L1 & L2

SEDBUK A RATED





## NOTES FOR THE INSTALLER

**FOR ANY TECHNICAL QUERIES PLEASE RING THE KESTON  
INSTALLER/TECHNICAL HELPLINE : 0208 462 0262**

**NOTE. BOILER RESET PROCEDURE -**

To reset boiler, turn mode knob to reset position and immediately turn knob back to required setting.  
The boiler will repeat the ignition sequence.

## DOCUMENT AMENDMENTS

Relevant Installation changes implemented in this book from Mod Level ..... A03 (June 2010)

**Page 17 - Frame 9, Flue System**

- Approved Solvent Weld Waste added

**Page 37 - Frame 38, Wiring Diagram**

- Wire removed from flame sensor electrode

**Page 73 - Short List of Parts**

- Key No. 111 - part number updated

---

*Keston reserve the right to vary specification without notice*

# GENERAL

**Table 1 - General Data**

Keston 30C			30
Gas supply			2H - G20 - 20mbar
Gas Supply Connection			15mm copper compression
Injector Size	(mm)		4.65
Inlet Connection	Domestic Hot Water		15mm copper compression
Outlet Connection	Domestic Hot Water		15mm copper compression
Flow Connection	Central Heating		22mm copper compression
Return Connection	Central Heating		22mm copper compression
Flue Terminal Diameter	mm (in)		50 (nominal)
Average Flue Temp-Mass Flow Rate	(DHW)		68°C - 13g/s
Maximum Working Pressure (Sealed Systems)	bar (lb/in <sup>2</sup> )		2.5 (36.3)
Maximum Domestic Hot Water Inlet Pressure	bar (lb/in <sup>2</sup> )		10.0 (145)
Minimum Domestic Hot Water Inlet Pressure*	bar (lb/in <sup>2</sup> )		1.3 (18.9)
Electrical Supply			230 V ~ 50 Hz.
Power Consumption	W		152
Fuse Rating			External : 3A Internal : T4H HRC L250 V
Water content	Central Heating	litre (gal)	1.2 (0.26)
	Domestic Hot Water	litre (gal)	0.5 (0.11)
Packaged Weight	kg (lb)		37.8 (83.3)
Maximum Installation Weight	kg (lb)		32.8 (72.3)
Boiler Casing Size	Height	mm (in)	700 (27.5)
	Width	mm (in)	395 (15.5)
	Depth	mm (in)	278 (11)

\*Required for maximum flow rate. Boiler operates down to 2 l/min DHW delivery

**Table 2 - Performance Data - Central Heating**

Boiler Input :		Max.	Min.	
Boiler Input 'Q'	Nett CV	kW	24.3	6.1
		(Btu/h)	(82,900)	(20,700)
	Gross CV	kW	27.0	6.7
		(Btu/h)	(92,000)	(23,000)
Gas Consumption		l/s	0.698	0.173
		(ft <sup>3</sup> /h)	(89)	(22)
Boiler Output :				
Non Condensing		kW	24.2	6.1
70°C Mean Water temp.		(Btu/h)	(82,600)	(20,700)
Condensing		kW	25.6	6.4
40°C Mean Water temp.		(Btu/h)	(87,400)	(21,800)
Seasonal efficiency*	(SEDBUK)	Band A	(91.1%)	
NOx Classification		CLASS 5		

**Table 3 - Performance Data - Domestic Hot Water**

Maximum DHW Input :		30
Nett CV	kW	30.4
	(Btu/h)	(103,600)
Gross CV	kW	33.7
	(Btu/h)	(115,000)
Gas Consumption	l/s	0.871
	(ft <sup>3</sup> /h)	(111)
Maximum DHW Output	kW (Btu/h)	30.3 (103,300)
DHW Flow Rate at 35°C temp. rise.	l/min (gpm)	12.4 (2.8)
DHW Specific Rate	l/min (gpm)	14.5 (3.2)

\* The value is used in the UK Government's Standard Assessment Procedure (SAP) for energy rating of dwellings. The test data from which it has been calculated have been certified by a notified body.

**Note.** Gas consumption is calculated using a calorific value of 38.7 MJ/m<sup>3</sup> (1038 Btu/ft<sup>3</sup>) gross or 34.9 MJ/m<sup>3</sup> (935 Btu/ft<sup>3</sup>) nett

To obtain the gas consumption at a different calorific value:

- For l/s - divide the gross heat input (kW) by the gross C.V. of the gas (MJ/m<sup>3</sup>)
- For ft<sup>3</sup>/h - divide the gross heat input (Btu/h) by the gross C.V. of the gas (Btu/ft<sup>3</sup>)
- For m<sup>3</sup>/h - multiply l/s by 3.6.

**Key to symbols**

**PMS** = Maximum operating pressure of water

**C<sub>13</sub> C<sub>33</sub> C<sub>53</sub>** = A room sealed appliance designed for connection via ducts to a horizontal or vertical terminal, which admits fresh air to the burner and discharges the products of combustion to the outside through orifices which, in this case, are concentric. The fan is up stream of the combustion chamber.

**I<sub>2H</sub>** = An appliance designed for use on 2nd Family gas, Group H only.

# GENERAL

## KESTON 30C

Natural Gas only

Boiler size	G.C. Appliance No. (Benchmark No.)	PI No.
30	47-930-03	86 CL 38

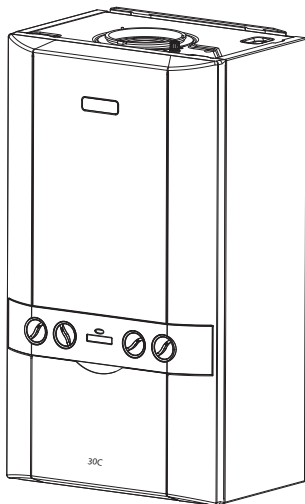

## CONTENTS

Benchmark Commissioning Checklist .....	75
Boiler Clearances .....	9
Boiler Exploded Diagram .....	13,14
Condensate Drain .....	9, 20, 46
Electrical Connections .....	31
Electrical Supply .....	8
Fault Finding .....	64-72
Flue Fitting .....	17, 18
Gas Safety Regulations .....	7
Gas Supply .....	8
Installation .....	15-43
Pump .....	59
Safe Handling .....	6
Servicing .....	44-63
Short List of Parts .....	73
Thermostatic Radiator Valves .....	8
Water and Systems .....	8, 10-12
Water Connections .....	28, 29
Water Treatment .....	12
Wiring Diagram .....	37

For GB, to comply with Building Regulations Part L1 (Part 6 in Scotland) the boiler should be fitted in accordance with the manufacturer's instructions. Self-certification that the boiler has been installed to comply with Building Regulations can be demonstrated by completing and signing the Benchmark Commissioning Checklist.

Before installing this boiler, read the Code of Practice sheet at the rear of this book.

### BENCHMARK COMMISSIONING CHECKLIST DETAILS

Boiler	Page		Page
Make and model .....	5	Burner operating pressure .....	n/a
Appliance serial no. on data badge .....	Front Cover	Central heating flow temp. ....	measure and record
SEDBUK No. % .....	4	Central heating return temp. ...	measure and record
<b>Controls</b>		<b>For combination boilers only</b>	
Time and temperature control to heating .....	32	Scale reducer .....	12
Time and temperature control to hot water .....	32	<i>Hot water mode</i>	
Heating zone valves .....	n/a	Heat input .....	to be calculated
TRV's .....	8	Max. operating burner pressure .....	n/a
Auto bypass .....	8	Max. operating water pressure .....	measure & record
Boiler interlock .....	8	Cold water inlet temp .....	measure & record
<b>For all boilers</b>		Hot water outlet temp. ....	measure & record
Flushing to BS.7593 .....	12	Water flow rate at max. setting .....	measure & record
Inhibitor .....	12	<b>For condensing boilers only</b>	
<i>Central heating mode</i>		Condensate drain .....	26
Heat input .....	to be calculated	<b>For all boilers: complete, sign &amp; hand over to customer</b>	
		For assistance see Technical Helpline on the back page	

**NOTE TO THE INSTALLER: COMPLETE THE BENCHMARK COMMISSIONING CHECKLIST AND LEAVE THESE INSTRUCTIONS WITH APPLIANCE**



## INTRODUCTION

The **Keston 30C** boiler is a wall mounted, full sequence, automatic spark ignition, low water content, fanned flue, high efficiency, condensing, combination gas boiler.

**Note.** *Due to the high efficiency of the boiler a plume of water vapour will form at the terminal during operation.*

Central heating (CH) output is fully modulating with a range of 6.1 to 24.2kW (20,700 to 82,600 Btu/h)

Instantaneous domestic hot water (DHW) output is also fully modulating with a maximum of 30.3kW (103,300 Btu/h)

The boiler is supplied fully assembled with DHW plate heat exchanger, diverter valve, circulating pump, pressure gauge, safety valve and CH expansion vessel.

Variable CH and DHW temperature controls are fitted on the user control and the boiler features a DHW preheat facility.

The boiler includes as standard:

- Automatic bypass
- Boiler frost protection
- Daily pump and diverter valve exercise.

The boiler casing is of white painted mild steel.

The boiler temperature controls are visible located in the control panel on the front of the boiler.

The heat exchanger is manufactured from cast aluminium.

The boiler is suitable for connection to fully pumped, sealed heating systems ONLY. Adequate arrangements for completely draining the system by provision of drain cocks MUST be provided in the installation pipework.

Pipework from the boiler is routed downwards.

## OPERATION

With no demand for CH, the boiler fires only when DHW is drawn off, or periodically for a few seconds without any DHW draw-off, in order to maintain the DHW calorifier in a heated condition. This only occurs if pre-heat knob is in the 'ON' period.

When there is a demand for CH, the heating system is supplied at the selected temperature of between 30°C and 80°C, until DHW is drawn off. The full output from the boiler is then directed via the diverter valve to the plate heat exchanger to supply a nominal DHW draw-off of 12.4 l/min at 35 °C temperature rise.

The DHW draw off rate specified above is the nominal that the boiler flow regulator will give. Due to system variations and seasonal temperature fluctuations DHW flow rates/temperature rise will vary, requiring adjustment at the draw off tap.

At low DHW draw-off rate the maximum temperature is limited to 64 °C by the modulating gas control.

The boiler features a comprehensive diagnostic system which gives detailed information on the boiler status when operating, and performance of key components to aid commissioning and fault finding.

## SAFE HANDLING

This boiler may require 2 or more operatives to move it to its installation site, remove it from its packaging base and during movement into its installation location. Manoeuvring the boiler may include the use of a sack truck and involve lifting, pushing and pulling.

Caution should be exercised during these operations.

Operatives should be knowledgeable in handling techniques when performing these tasks and the following precautions should be considered:

- Grip the boiler at the base.
- Be physically capable.
- Use personal protective equipment as appropriate, e.g. gloves, safety footwear.

During all manoeuvres and handling actions, every attempt should be made to ensure the following unless unavoidable and/or the weight is light.

- Keep back straight.
- Avoid twisting at the waist.
- Avoid upper body/top heavy bending.
- Always grip with the palm of the hand.
- Use designated hand holds.
- Keep load as close to the body as possible.
- Always use assistance if required.

## OPTIONAL EXTRA KITS

- **Telescopic Concentric Flue B pack**
- **Electronic Timer (7 day) kit**
- **RF Electronic Programmable Room Thermostat kit**
- **Stand Off kit**

## SAFETY

### Current Gas Safety (installation and use) regulations or rules in force:

The appliance is suitable only for installation in GB and IE and should be installed in accordance with the rules in force.

In GB, the installation must be carried out by a Gas Safe Registered Engineer. It must be carried out in accordance with the relevant requirements of the:

- Gas Safety (Installation and Use) Regulations
- The appropriate Building Regulations either The Building Regulations, The Building Regulations (Scotland), Building Regulations (Northern Ireland).
- The Water Fittings Regulations or Water byelaws in Scotland.
- The Current I.E.E. Wiring Regulations.

Where no specific instructions are given, reference should be made to the relevant British Standard Code of Practice.

In IE, the installation must be carried out by a Registered Gas Installer (RGI) and installed in accordance with the current edition of I.S.813 "Domestic Gas Installations", the current Building Regulations and reference should be made to the current ETCI rules for electrical installation.

Detailed recommendations are contained in the following British Standard Codes of Practice:

- BS. 5440:1** Flues (for gas appliances of rated input not exceeding 70 kW).
- BS. 5440:2** Ventilation (for gas appliances of rated input not exceeding 70 kW).
- BSEN. 12828:2003** Heating Systems in buildings: Design for water based heating systems.
- BSEN 12831:2003** Heating Systems in buildings: Method for calculation of the design heat load.
- BSEN 14336:2004** Heating Systems in buildings: Installation and commissioning of water based heating systems.
- BS. 5546** Installation of gas hot water supplies for domestic purposes (2nd Family Gases)
- BS. 6798** Installation of gas fired hot water boilers of rated input not exceeding 70 kW.
- BS. 6891** Low pressure installation pipes.

### Health & Safety Document No. 635.

### The Electricity at Work Regulations, 1989.

The manufacturer's notes must NOT be taken, in any way, as overriding statutory obligations.

**IMPORTANT.** These appliances are CE certificated for safety and performance. It is, therefore, important that no external control devices, e.g. flue dampers, economisers etc., are directly connected to these appliances unless covered by these Installation and Servicing Instructions or as otherwise recommended by Keston in writing. If in doubt please enquire.

Any direct connection of a control device not approved by Keston could invalidate the certification and the normal appliance warranty. It could also infringe the Gas Safety Regulations and the above regulations.

## SAFE HANDLING OF SUBSTANCES

No asbestos, mercury or CFCs are included in any part of the boiler or its manufacture.

## LOCATION OF BOILER

The boiler must be installed on a flat and vertical internal wall, capable of adequately supporting the weight of the boiler and any ancillary equipment.

The boiler may be fitted on a combustible wall and insulation between the wall and the boiler is not necessary, unless required by the local authority.

For electrical safety reasons there must be no access available from the back of the boiler.

### **The boiler must not be fitted outside.**

### Timber Framed Buildings

If the boiler is to be fitted in a timber framed building it should be fitted in accordance with the Institute of Gas Engineering document IGE/UP/7:1998.

### Bathroom Installations

This appliance is rated **IP20**.

The boiler may be installed in any room or internal space, although particular attention is drawn to the requirements of the current IEE (BS.7671) Wiring Regulations and the electrical provisions of the building regulations applicable in Scotland, with respect to the installation of the boiler in a room or internal space containing a bath or shower. For IE reference should be made to the current ETCI rules for electrical installations and I.S. 813:2002.

If the appliance is to be installed in a room containing a bath or shower then, providing water jets are not going to be used for cleaning purposes (as in communal baths/showers), the appliance must be installed beyond Zone 2, as detailed in BS.7671.

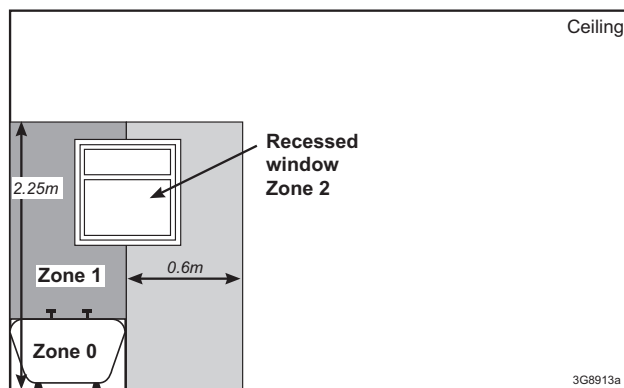

### Compartment Installations

A compartment used to enclose the boiler should be designed and constructed specially for this purpose.

An existing cupboard or compartment may be used, provided that it is modified for the purpose.

In both cases, details of essential features of cupboard / compartment design, including airing cupboard installation, are to conform to the following:

- BS 6798 (No cupboard ventilation is required - see 'Air Supply' for details).
- The position selected for installation MUST allow adequate space for servicing in front of the boiler.
- For the minimum clearances required for safety and subsequent service, see the wall mounting template and Frame 1. In addition, sufficient space may be required to allow lifting access to the wall mounting plate.
- The boiler must be installed on a fire resistant surface.

## GENERAL

### GAS SUPPLY

The local gas supplier should be consulted, at the installation planning stage, in order to establish the availability of an adequate supply of gas. An existing service pipe must NOT be used without prior consultation with the local gas supplier.

The boiler MUST be installed on a gas supply with a governed meter only.

A gas meter can only be connected by the local gas supplier or by a Gas Safe Registered Engineer. In IE by a Registered Gas Installer (RGI).

An existing meter should be checked, preferably by the gas supplier, to ensure that the meter is adequate to deal with the rate of gas supply required.

It is the responsibility of the Gas Installer to size the gas Installer to size the gas installation pipework in accordance with BS6891:2005. Whilst the principle of the 1:1 gas valve ensures the Keston 30C is able to deliver its full output at inlet pressures as low as 14mb, other gas appliances in the property may not be as tolerant. When operating pressures are found to be below the minimum meter outlet of 19mb these should be checked to ensure this is adequate for correct and safe operation.

Allowing for the acceptable pressure loss of 1mb across the installation pipework, it can be assumed that a minimum permitted operating pressure of 18mb will be delivered to the inlet of the appliance. (Reference BS 6400-1 Clause 6.2 Pressure Absorption).

The integral appliance isolation valve and boiler pipework could further reduce the operating pressure by up to 1.5mb when measured at the inlet test point on the appliance gas valve. Therefore it has been identified that an operating pressure as low as 16.5mbar could be measured at the appliance inlet pressure test point on the gas valve.

#### **IMPORTANT.**

Installation pipes must be fitted in accordance with BS.6891. In IE refer to IS.813:2002.

The complete installation MUST be tested for gas tightness and purged as described in the above code.

### WATER CIRCULATION SYSTEM

#### **IMPORTANT.**

A minimum length of 1 metre of copper pipe MUST be fitted to both flow and return connections from the boiler before connection to any plastic piping.

The central heating system should be in accordance with BS.6798 and, in addition, for smallbore and microbore systems, BS.5449.

**WATER TREATMENT - see Frame 5**

### BOILER CONTROL INTERLOCKS

Central heating systems controls should be installed to ensure the boiler is switched off when there is no demand for heating, in compliance with Building Regulations.

Heating systems utilising full thermostatic radiator valve control of temperature in individual rooms should also be fitted with a room thermostat controlling the temperature in a space served by radiators not fitted with such a valve.

When thermostatic radiator valves are used, the space heating temperature control over a living / dining area or hallway having a heating requirement of at least 10% of the minimum boiler heat output should be achieved using a room thermostat, whilst other rooms are individually controlled by thermostatic radiator valves. However, if the system employs thermostatic radiator valves on all radiators, or two port valves, then a bypass circuit must be fitted with an automatic bypass valve to ensure a flow of water should all valves be in the closed position.

### ELECTRICAL SUPPLY

#### **WARNING.**

This appliance must be earthed.

Wiring external to the appliance MUST be in accordance with the current I.E.E. (BS.7671) Wiring Regulations and any local regulations which apply. For IE reference should be made to the current ETCI rules for electrical installations.

The mains supply to the boiler and system wiring centre shall be through one common fused double pole isolator and for new heating systems, and where practical replacement boiler installations, the isolator shall be situated adjacent to the appliance.

### CONDENSATE DRAIN

#### **Refer to Frames 15, 25 & 48**

A condensate drain is provided on the boiler. This drain must be connected to a drainage point on site. All pipework and fittings in the condensate drainage system MUST be made of plastic - *no other materials may be used.*

#### **IMPORTANT.**

Any external runs must be in accordance with BS 6798.

The drain outlet on the boiler is sized for standard 21.5mm (3/4") overflow pipe. It is a universal fitting to allow use of different brands of pipework.



# GENERAL

## 1 BOILER DIMENSIONS, SERVICES & CLEARANCES

all dimensions in mm

The boiler connections are made on the boiler connection tails. Refer to Frames 27-30.

The following minimum clearances must be maintained for operation and servicing.

Additional space will be required for installation, depending upon site conditions.

### CLEARANCES

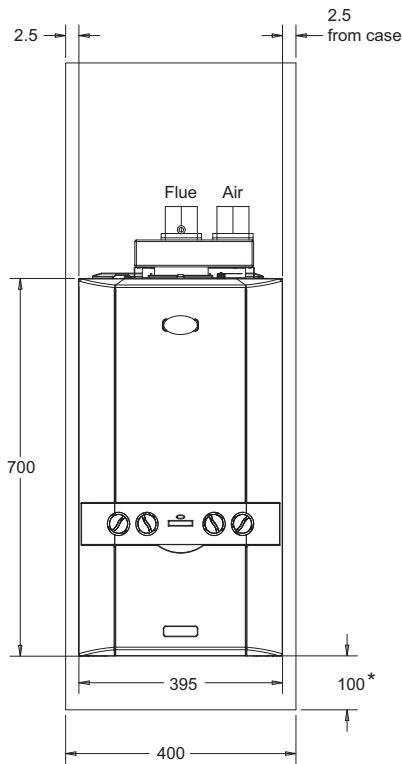

### BOILER DIMENSIONS

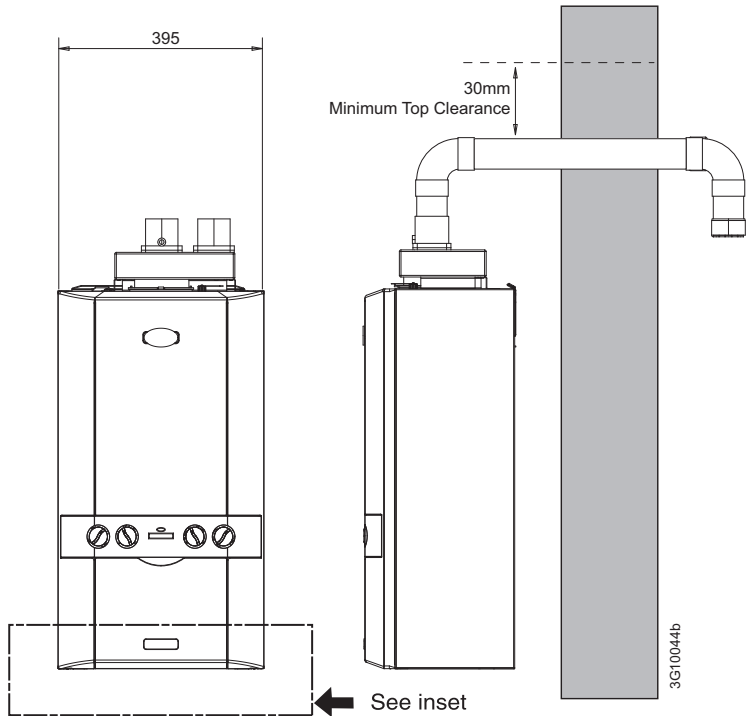

### Inset: Water Connections and Gas Connection

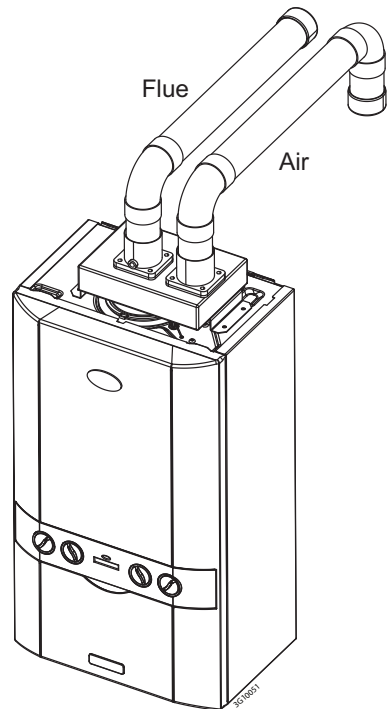
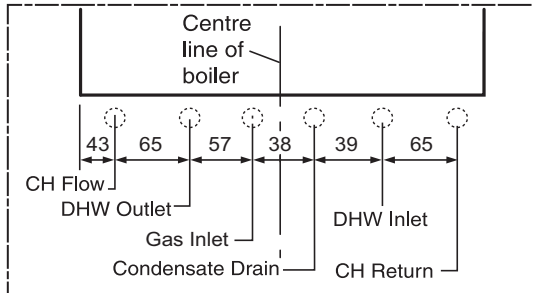

### Front clearance

The minimum front clearance when built in to a cupboard is 5mm from the cupboard door but 450mm overall clearance is still required, with the cupboard door open, to allow for servicing.

### \* Bottom clearance

Bottom clearance after installation can be reduced to 5mm. This must be obtained with an easily removable panel, to enable the consumer to view the system pressure gauge, and to provide the 100mm clearance required for servicing.

# GENERAL

## 2 SYSTEM REQUIREMENTS - Central Heating

### Notes

- a. The method of filling, refilling, topping up or flushing sealed primary hot water circuits from the mains via a temporary hose connection is only allowed if acceptable to the local water authority.
- b. Antifreeze fluid, corrosion and scale inhibitor fluids suitable for use with boilers having aluminium heat exchangers may be used in the central heating system.

### General

1. The installation must comply with all relevant national and local regulations.
2. The installation should be designed to work with flow temperatures of up to 86 °C.
3. All components of the system must be suitable for a working pressure of 3 bar and temperature of 110 °C. Extra care should be taken in making all connections so that the risk of leakage is minimised.  
  
The following components are incorporated within the appliance:
  - a. Circulating pump.
  - b. Safety valve, with a non-adjustable preset lift pressure of 3 bar.
  - c. Pressure gauge, covering a range of 0 to 4 bar.
  - d. An 8-litre expansion vessel, with an initial charge pressure of 0.75 bar.
4. **'Make-up' Water.** Provision must be made for replacing water loss from the system, either :
  - a. From a manually filled 'make-up' vessel with a readily visible water level. The vessel should be mounted at least 150mm above the highest point of the system and be connected through a non-return valve to the system, fitted at least 150mm below the 'make-up' vessel on the return side of the radiators. **or**
  - b. Where access to a 'make-up' vessel would be difficult, by pre-pressurisation of the system.

The maximum cold water capacity of the system should not exceed 143 litres, if not pressurized. However, if the system is to be pressurized, the efficiency of the expansion vessel will be reduced and a larger vessel (or smaller system volume) may be necessary. If the capacity of the vessel is not considered sufficient for this, or for any other reason, an additional vessel **MUST** be installed on the RETURN to the boiler.

Guidance on vessel sizing is given in Table above.

<b>Safety valve setting</b>	bar	3.0	
<b>Vessel charge pressure</b>	bar	0.5 to 0.75	
<b>System pre-charge pressure</b>	bar	None	1.0
<b>System volume (litres)</b>		<b>Expansion vessel volume (litres)</b>	
25		1.6	1.8
50		3.1	3.7
75		4.7	5.5
100		6.3	7.4
125		7.8	9.2
150		9.4	11.0
175		10.9	12.9
190		11.9	14.0
200		12.5	14.7
250		15.6	18.4
300		18.8	22.1
<b>For other system volumes multiply by the factor across</b>		0.063	0.074

### Water Flow Rate and Pressure Loss

Max CH Output	kW (Btu/h)	24.2 (82,600)
Water flow rate	l/min (gal/min)	17.3 (3.8)
Temperature Differential	°C (°F)	20 (36)
Head available for system	m.w.g. (ft.w.g.)	3.4 (11.1)

### 5. Filling

The system may be filled by the following method:

Where the mains pressure is excessive a pressure reducing valve must be used to facilitate filling.

- a. Thoroughly flush out the whole system with cold water.
- b. Fill and vent the system until the pressure gauge registers 1bar and examine for leaks. Refer to Frame 33 for filling detail.
- c. Check the operation of the safety valve by raising the water pressure until the valve lifts. This should occur within 0.3bar of the preset lift pressure.
- d. Release water from the system until the minimum system design pressure is reached; 1.0 bar if the system is to be pre-pressurised.

*continued . . . . .*

## GENERAL

### 3 SYSTEM REQUIREMENTS - CH (continued) and Hot Water

#### DOMESTIC HOT WATER

1. The domestic hot water service must be in accordance with BS 5546 and BS 6700.
2. Refer to Table 1 for minimum and maximum working pressures. In areas of low mains water pressures the domestic hot water regulator may be removed from the DHW flow turbine cartridge. Refer to Frame 76. The boiler will require the flow rate to be set to obtain a temperature rise of 35°C at the tap furthest from the boiler.
3. The boiler is suitable for connection to most types of washing machine and dishwasher appliances.
4. When connecting to suitable showers, ensure that:
  - a. The cold inlet to the boiler is fitted with an approved anti-vacuum or syphon non-return valve.
  - b. Hot and cold water supplies to the shower are of equal pressure.
5. **Hard Water Areas**  
Where the water hardness exceeds 200mg/litre, it is recommended that a proprietary scale reducing device is fitted into the boiler cold supply within the requirements of the local water company.

#### IMPORTANT

Provision MUST be made to accommodate the expansion of DHW contained within the appliance, if a non-return valve is fitted to the DHW inlet, or a water meter with a non-return valve is installed.

### 4 SYSTEM BALANCING

The boiler does not normally need a bypass but at least some radiators on the heating circuit, of load of at least 10% of the minimum boiler output, must be provided with twin lockshield valves so that this minimum heating load is always available. See note regarding thermostatic radiator valves on page 8.

**Note.** *Systems incorporating zone valves which could completely cut off the flow through the system must also include a bypass.*

#### BALANCING

1. Set the programmer to ON.  
Close the manual or thermostatic valves on all radiators, leaving the twin lockshield valves (on the radiators referred to above) in the OPEN position.  
Turn up the room thermostat and adjust the lockshield valve to give an uninterrupted flow through the radiator.
2. Open all manual or thermostatic radiator valves and adjust the lockshield valves on the remaining radiators, to give around 20°C temperature drop at each radiator.
3. Adjust the room thermostat and programmer to NORMAL settings.

These valves should now be left as set.

## 5 WATER TREATMENT

### CENTRAL HEATING

The Keston 30C boiler has an ALUMINIUM alloy heat exchanger.

#### IMPORTANT.

**The application of any other treatment to this product may render the guarantee of Keston Invalid.**

Keston recommend Water Treatment in accordance with the Benchmark Guidance Notes on Water Treatment in Central Heating Systems.

If water treatment is used Keston recommend only the use of FERNOX, MBI or SENTINEL X100 inhibitors and associated water treatment products, which must be used in accordance with the manufacturers' instructions.

#### Notes.

- 1. It is most important that the correct concentration of the water treatment products is maintained in accordance with the manufacturers' instructions.*
- 2. If the boiler is installed in an existing system any unsuitable additives MUST be removed by thorough cleansing. BS 7593:2006 details the steps necessary to clean a domestic heating system.*
- 3. In hard water areas, treatment to prevent lime scale may be necessary - however the use of artificially softened water is NOT permitted.*
- 4. Under no circumstances should the boiler be fired before the system has been thoroughly flushed.*

### DOMESTIC HOT WATER

In hard water areas where mains water can exceed 200ppm Total Hardness (as defined by BS 7593:2006 Table 2) a scale reducing device should be fitted into the boiler cold supply within the requirements of the local water company. The use of artificially softened water, however, is not permitted.

Keston recommend the use of Fernox Quantomat, Sentinel Combiguard and Calmag CalPhos I scale reducing devices, which must be used in accordance with the manufacturers' instructions.

For further information contact:

Fernox Manufacturing Co. Ltd  
Cookson Electronics  
Forsyth Road  
Sheerwater  
Woking  
Surrey GU21 5RZ  
+44 (0) 1799 521133

Sentinel Performance Solutions  
The Heath Business & Technical Park  
Runcorn  
Cheshire WA7 4QX  
Tel: 0800 389 4670  
[www.sentinel-solutions.net](http://www.sentinel-solutions.net)

Salamander Engineering Ltd  
The Heath Business & Technical Park  
Runcorn  
Cheshire WA7 4QX  
Tel: 0800 389 4670

Calmag Ltd.  
Unit 4-6, Crown Works  
Bradford Road  
Sandbeds, Keighley  
West Yorkshire BD20 5LN  
Tel: +44 (0) 1535 210 320

# INSTALLATION

## 6 BOILER ASSEMBLY - Exploded View Legend

Note that item numbers are linked to the spares list

104	CH RETURN VALVE	218	GASKET - BURNER
105	CH FLOW VALVE	219	SUMP CLEAN OUT COVER
106	DHW INLET & OUTLET	223	FLUE MANIFOLD
107	FILLING LOOP	224	FLUE MANIFOLD TOP
108	PUMP HEAD	227	CLAMP RETAINING FLUE TURRET
110	AIR VENT PUMP	228	HOSE CONDENSATE INTERNAL
111	DIVERTER VALVE HEAD	229	SIPHON TRAP
112	DIVERTE R VALVE CARTDRIGE	230	SIPHON TRAP CAP & SEAL
113	PRESSURE RELIEF VALVE	231	CONDENSATE OUTLET CONNECTION
114	PIPE - PRV OUTLET	233	FLUE SENSING NIPPLE
115	PIPE - FLOW	301	CONTROLS BOX FIXINGS HINGE & SPRING
116	PIPE - RETURN	302	PRIMARY PCB
117	PIPE - EXPANSION VESSEL	303	CUI BOARD
118	EXPANSION VESSEL	304	CONTROL THERMISTOR (FLOW / RETURN)
119	RETURN GROUP MANIFOLD	306	ELECTRODE IGNITION
120	FLOW GROUP MANIFOLD	307	ELECTRODE DETECTION
121	PLATE HEAT EXCHANGER	308	IGNITER UNIT
127	FLOW SENSOR HALL EFFECT	309	THERMISTOR NO FLOW
128	FLOW TURBINE CARTRIDGE	313	IGNITION LEAD
131	WATER PRESSURE TRANSDUCER	314	CONTROL BOX LENS
135	PRESSURE GAUGE	324	CONTROLS BOX LID
203	GAS COCK	325	CONTROL BOX FRONT
204	PIPE - GAS INLET	326	PROGRAMMER INSERT
205	GAS VALVE	401	HEAT ENGINE
206	PIPE - GAS INJECTOR	503	WALL MOUNTING BRACKET
211	INJECTOR ASSEMBLY	504	FRONT PANEL
214	VENTURI	505	FASCIA
215	FAN	506	BRACKET - GAS VALVE
217	BURNER	507	BRACKET - EXPANSION VESSEL
		136	SAFETY VALVE DRAIN PIPE
		512	DROP DOWN DOOR
		332	FLUE THERMOSTAT

# INSTALLATION

## 7 BOILER ASSEMBLY - Exploded View (excluding flue box)

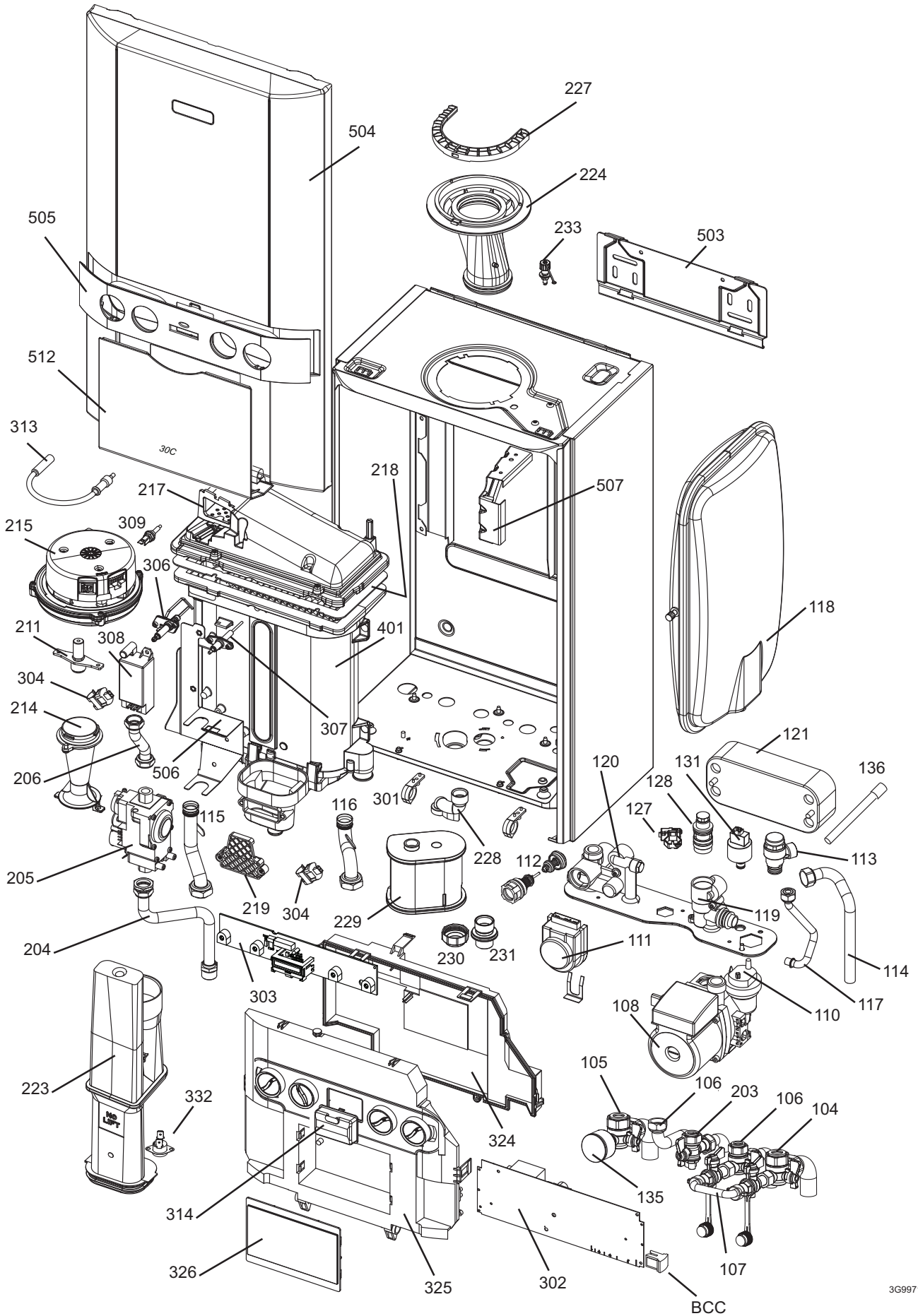

3G9971b

# INSTALLATION

## 8 UNPACKING

The boiler is supplied fully assembled in Pack 1, together with Pack 2 for flue lengths up to 450mm.

Unpack and check the contents.

### Pack 1 Contents

- A Boiler
- B Hardware Pack Box
- C Wall Mounting Plate
- D These Installation Instructions (includes Warranty/Guarantee)
- E Wall Mounting Template (located on internal protective packaging)
- F Turret Clamp
- G Safety Valve Drain Pipe
- H Weather Compensator

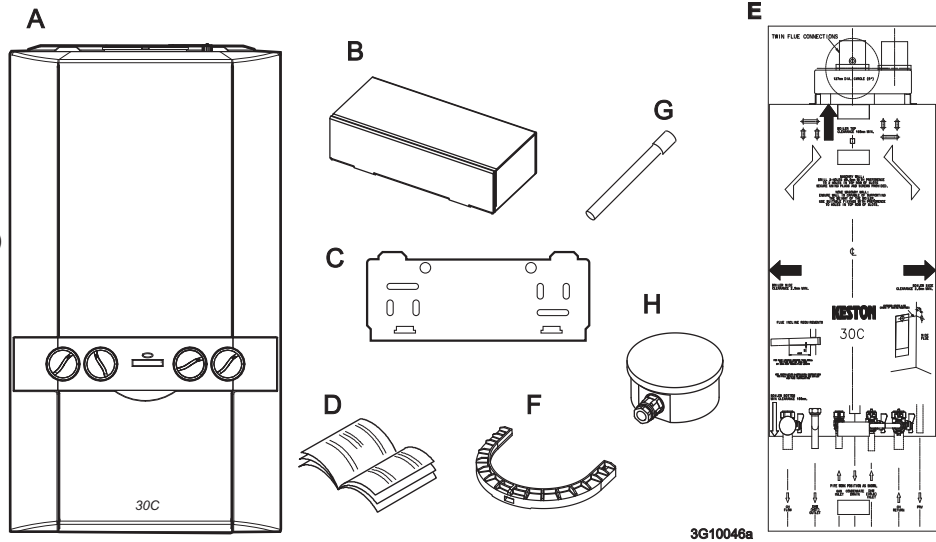

### HARDWARE PACK CONTENTS

#### Gas Valve Pack

1. Pipe - Gas Inlet
2. Washer - Gas (blue)
3. Gas Cock

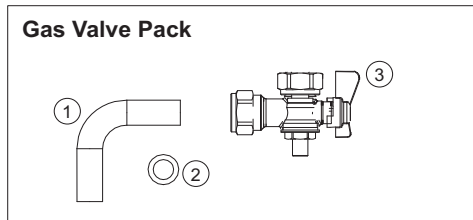

#### Filling Loop Pack

1. 3/8" Fibre washer (x4)
2. Valve (double check valve) fitting
3. Valve - Filling Loop
4. Plastic Chain (x2)
5. Filling Loop
6. 3/8" Blanking Rubber Washer (x2)

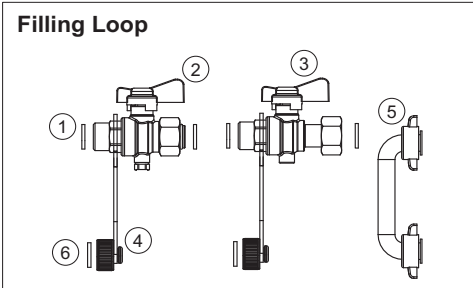

#### Return Valve Pack

1. Pipe CH Return
2. Washer CH
3. Valve Return

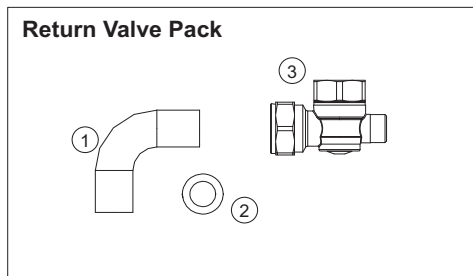

#### DHW Pack

1. Pipe DHW Outlet
2. Valve - Return DHW
3. Washer DHW (x2)
4. Pipe DHW Inlet
5. Nut 1/2"

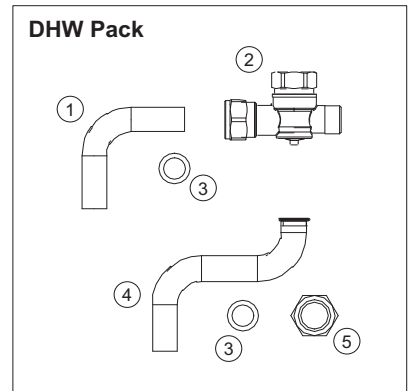

#### Accessory Pack

1. Screw (x2)
2. Wallplug (x2)

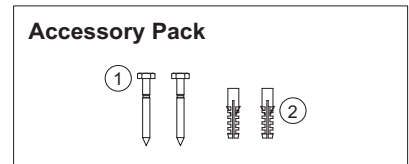

#### Flow Valve Pack

1. Pipe CH Flow
2. Washer CH
3. Valve Flow (with gauge)

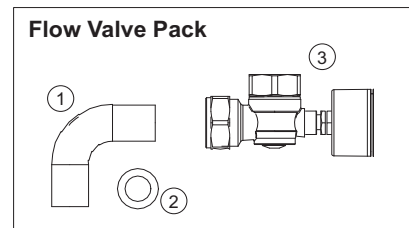

3G9687

continued . . . . .

# INSTALLATION

## 8 UNPACKING...CONT'D

### Pack 2 Contents

2 Boxes

### Pack 2a Contents

1. 3 x elbows
2. 2 x 450mm pipe
3. 3 x 100mm pipe

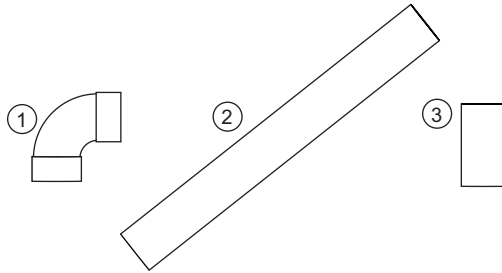

### Pack 2b Contents

1. Top Flue Box
2. 6 x screws
3. 2 x Terminals

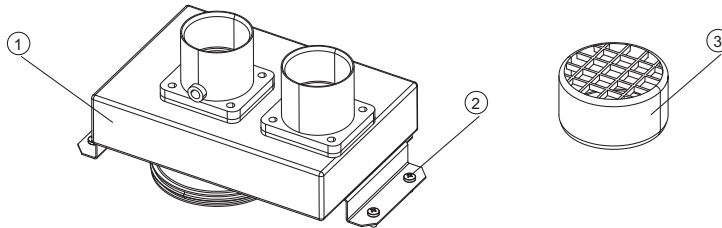



# INSTALLATION

## 9 FLUE SYSTEM

**Note.** When installing a replacement boiler a new flue system must be used. Do not re-use the existing boiler flue installation.

### DESIGN

Individual air supply and flue outlet pipes are used as standard, although a concentric flue kit is available as an optional extra.

The material used for flue outlet &/or air inlet **must be muPVC (PVC-C) to BS 5255 and/or BSEN 1566-1 and BSEN 1329 of an internal diameter of 51mm. (i.e. nominal 50mm diameter muPVC solvent weld waste pipe).**

**Marley muPVC (PVC-C) Solvent Weld Waste System (50mm) and Polypipe System 2000 muPVC (PVC-C) solvent weld waste (50mm) are the only systems approved for this application.**

The following pipes and fittings are approved:

Polypipe System 2000 muPVC solvent Weld Waste System (50mm)

Poly Pipe Code	
MU 301	4m length muPVC wastepipe 5/225
MU 313	50mm x 45 deg muPVC obtuse bend
MU 314	50mm x 92.5 deg muPVC swept bend
MU 310	50mm muPVC straigh coupling
MU 316	50mm x 92.5 deg muPVC swept pipe

Marley muPVC solvent Weld Waste System (50mm)

Marley Code	
KP 304	50mm x 4m double spigot pipe
KP32	50mm x 45 deg bend
KSC3	50mm straight coupling
KB3	50mm x 88.5 deg bend
KT3	50mm swept tee

Both the 50mm flue outlet terminal and the 50mm air inlet terminal are supplied with the twin flue box (pack 2b) and are illustrated in Fig. 1 and must be used in ALL installations. (Both terminals are identical).

Fig.1

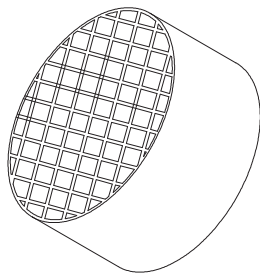

When the flue and air terminals are located within 500mm of each other ensure that the air terminal is pointing towards the ground using a 90° bend and one of the 100mm sections of pipe provided within pack 2a.

Fig.2a

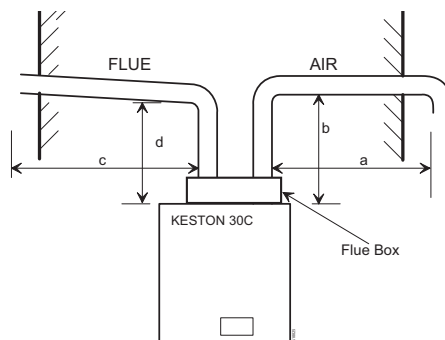

### MAXIMUM LENGTHS

The maximum lengths of both air inlet pipe and flue outlet pipe, when no bends are used, are as detailed in fig.2b.

However, each bend used has an equivalent length that must be deducted from the maximum straight length stated in fig. 2b. Knuckle bends must not be fitted.

A 92.5° swept elbow is equivalent to 1.0m straight length. A 45° bend is equivalent to 0.5m straight length.

It is possible to have variable flue and air lengths as detailed below.

Fig. 2b

Maximum Combined Flue & Air Intake Lengths	
Air Inlet	21m
Flue Outlet	21m
Total Flue & Air Intake	22m

(does not include allowance for elbow on top of boiler)

Example (assuming 50mm muPVC flue and air pipework)

Air inlet uses two 92.5° swept elbows. Hence, maximum length permissible (i.e. a+b in fig. 2a) = 22m - 1m - 1m = 20m.

Flue outlet uses one 92.5° swept elbow. Hence, maximum length permissible (i.e. c+d in fig. 2a) = 22m - 1m = 21m).

But maximum total flue and air intake must not exceed 19m in the examples above.

### Boiler Output Vs Flue Length

Due to the resistance presented by extended flue length a slight reduction in maximum boiler output will occur where combined flue and air lengths in excess of 16.0m (50mm muPVC) are used. In such cases the boiler output will be reduced by 1.0% per additional metre.

# INSTALLATION

## 09 FLUE SYSTEM.... CONT'D

### SLOPE

'Horizontal' flue outlet pipework **MUST** slope at least 2 degrees (32mm per metre run) downwards towards the boiler. Pipework can be vertical. Only swept elbows can be used.

Air inlet pipework can be truly horizontal or vertical, or sloping in a downward direction towards the boiler but in each case rain, etc., **must** be prevented from entering the pipe. **There must be no troughs in any of the pipework, whether it be air inlet or flue outlet.**

Due to the low temperature of the flue gases further condensate will form within the flue system. Drain points, with suitable traps, must therefore be incorporated within the flue system at the base of the vertical flue sections in excess of 6m, for 50mm muPVC pipe flue systems. These additional condensate drains must be run to discharge. Such drain points can be formed using standard muPVC fittings. Refer to fig. 3.

Fig.3

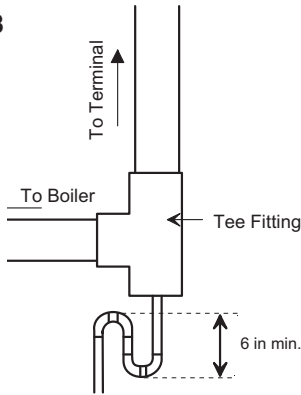

### TERMINATIONS

Air inlet terminals must be facing horizontally or downwards to prevent entry of rain into the terminal and positioned to ensure only fresh air is drawn into the boiler. The air terminal must be located outside of the building. Flue terminals must be positioned so that flue products are not drawn into the air inlet. Site specific wind conditions should be considered to achieve this. Drawing of combustion air directly from a ventilated boiler room invalidates the heat exchanger warranty.

The flue outlet terminal is designed to face outwards and must not be directed in the region of the air inlet. The flue terminal and air inlet terminal can be located on different, but not opposing wall faces.

The two terminals are subject to the requirements of BS 5440 Pt 1 for clearances from features of the building although some can be decreased to the values indicated.

The Keston 30C, as with any condensing boiler, will generate a condensate "plume" from the flue terminal in all weather conditions. Consideration must therefore be given to the effect of this "plume" when selecting a location for the flue terminal. It is the responsibility of the installer to ensure the selected terminal location does not cause nuisance.

If either the air inlet or flue outlet terminate at a height of less than 2.1m above ground level, the terminal must be protected by a suitable guard. The K6 terminal guard (with plastic coating), manufactured by Tower Flue Components Ltd is suitable for this purpose.

Dimensions (mm)	Flue Terminal	Air Inlet
A Below, above or beside openable window, air brick, etc.	300	50
B Below gutters, soil pipes, drain pipes.	75	75
C Below eaves.	200	50
D Below balconies or car port roof (lowest point).	200	50
E From vertical drain or soil pipes.	75	50
F From internal or external corner or to a boundary alongside the terminal. *	200	50
G Above ground or balcony or roof.	300	100
H From surface or boundary facing a terminal. *	600	100
I From terminal facing a terminal.	1,200	1,200
J From opening in a car port.(not recommended)	1,200	100
K Vertically from terminal on same wall.	1,500	1,500
L Horizontally from terminal on same wall.	300	300

361002/8a

\*The dimensions given in the table above may need to be increased to avoid wall staining and nuisance depending on site conditions.

### CLEARANCES FROM WALL

Flue outlet and air inlet terminations must be at least 40mm from the wall face.

### DISTANCE BETWEEN FLUE OUTLET & AIR INLET

There is no maximum - the terminations must not be on opposite sides of the dwelling but can be in areas of unequal pressure.

A minimum clearance of at least 500mm must be left between the terminations otherwise a 90° elbow **MUST** be fitted to air inlet and pointed towards the ground. The absolute minimum clearance between the flue and air terminals is 100mm.

### GENERAL INSTALLATIONS

All parts of the system must be constructed in accordance with BS 5440 Part 1, except where specifically mentioned in these instructions.

All pipework must be adequately supported.

All joints other than approved push-on or plastic compression connectors must be made and sealed with solvent cement suitable for muPVC pipes and conforming to BS 6209: 1982.

Consideration must be given to Corgi/Gas Safe bulletin TB200/TB008 regarding flues in voids.

The boiler casing must always be correctly fitted to the boiler when leaving the appliance operational.

External wall faces and any internal faces of cavity walls must be good.

Rubber collars are available for flue and air terminals to finish the external wall face around the terminals (Part No C.08.00.07.0).

### AIR SUPPLY

The Keston 30C is a room sealed appliance and therefore does not require purpose provided ventilation to the boiler room for combustion air.

### COMPARTMENT INSTALLATION

Due to the low casing temperatures generated by the boiler, no compartment ventilation is required. However, the cupboard or compartment must not be used for storage.

FLUE OUTLET

## 10 INSTALLING THE BOILER

Installation of the boiler is straightforward but consideration must be given to access to allow flue and air pipes to be pushed through walls and ceilings. The order in which the components are installed will depend upon particular site conditions, but in general it will be easiest and most accurate to install the boiler and then build up the flue outlet and air inlet pipes to the terminal - this is the sequence described.

## 11 WALL MOUNTING TEMPLATE

The wall mounting template is located on the internal protective packaging.

**Note.**

*The template shows the positions of the fixing holes and the position that the twin flue box is located. Care MUST be taken to ensure the correct holes are drilled.*

1. Tape template into the selected position. Ensure squareness by hanging a plumbline as shown.
2. Mark onto the wall the following:
  - a The wall mounting plate screw positions (choose one from each group).
  - b The position of the air and flue when exiting straight out of the wall where the boiler is mounted.

**Note.** Mark the centre of the hole as well as the circumference.

3. Remove the template from the wall.

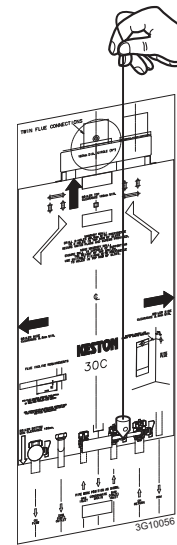

## 12 PREPARING THE WALL

**IMPORTANT.**

Ensure that, during the cutting operation, masonry falling outside of the building does not cause damage or personal injury.

1. Cut the flue and air holes (preferably with 60mm core bore tool) ensuring the holes are square to the wall.
2. Drill 2 holes with a 7.5mm / 8mm masonry drill and insert the plastic plugs, provided, for the wall mounting plate.
3. Locate 2 No.14 x 50mm screws in the wall mounting plate (one at each side, in any of the 3 holes provided at each side) and screw home.

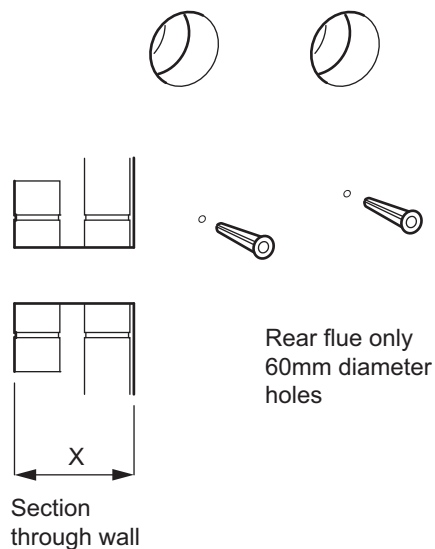

**Note.** Check all of the hole positions before drilling.

3G10030

# INSTALLATION

## 13 FITTING THE WALL MOUNTING PLATE

Screw the wall mounting plate to the wall using 2 wall plugs (previously fitted) with the 2 screws provided.

Choose one of the 2 sets of slots in left and right bank. Ensuring that at least one of the screws is fitted into a top slot.

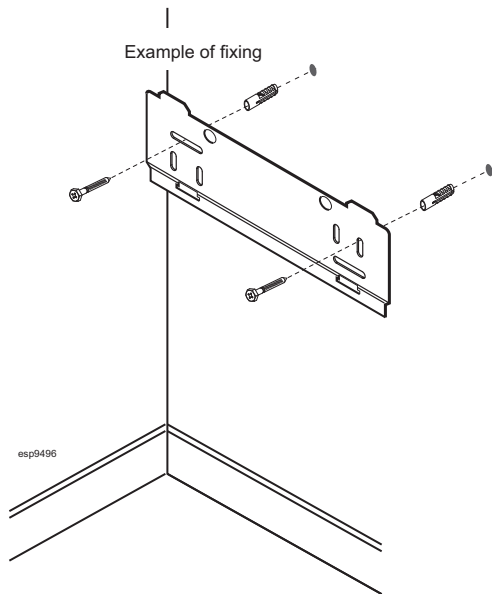

## 14 MOUNTING THE BOILER

1. Ensure the plastic plugs are removed from both the CH and DHW connections before mounting the boiler.
2. Lift the boiler onto the wall mounting plate (refer to the Introduction section for safe handling advice), locating it over the two tabs.

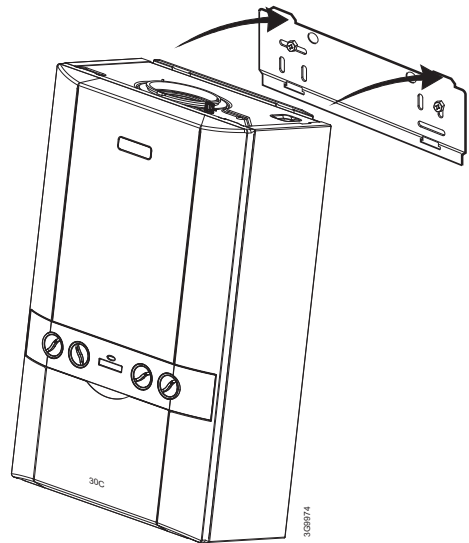

## 15 CONDENSATE DRAIN

Ensure that the siphon is full of water before commissioning the boiler. Refer to Frame 26.

The routing of the drain must be made to allow a minimum fall of 1 in 20 away from the boiler, throughout its length.

The drainage pipework must be arranged so that obstruction (e.g. through freezing) of external drainage pipe does not give rise to spillage within the dwelling.

### IMPORTANT.

All pipework and fittings in the condensate drain system must be made of plastic. No other materials may be used.

The drain outlet on the boiler is standard 21.5mm overflow pipe and is suitable for either push fit or solvent weld applications. This size must not be reduced in any part of its length.

The boiler includes as standard, a 75mm condensate trap. The condensate trap also includes a siphon to reduce the possibility of freezing in the drain outlet.

If external condensate pipe is used then the pipe should be 32mm nominal diameter. Consideration should be given to insulating external condensate pipe runs.

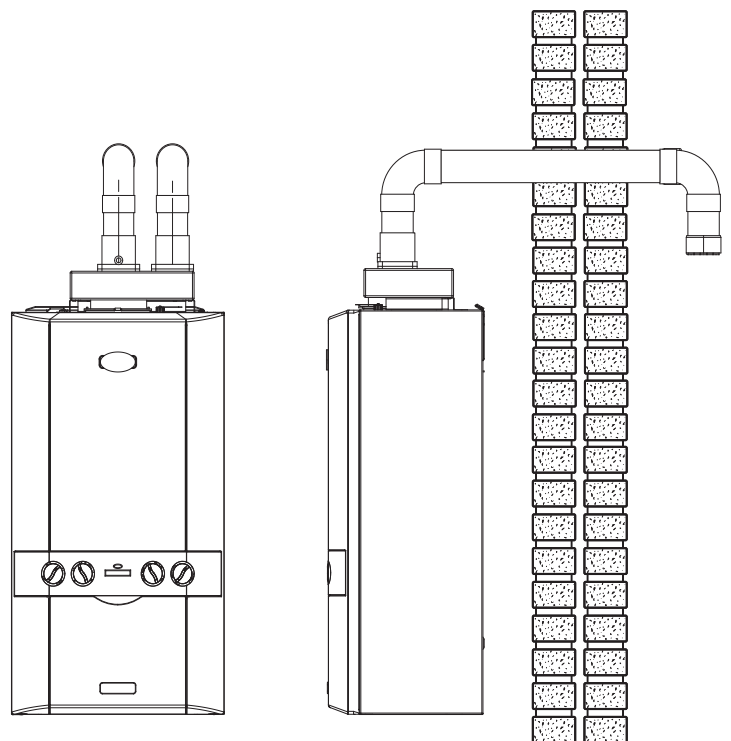

## 16 ASSEMBLY PRACTICE

Remove all plastic debris and burrs when installing air intake piping. Plastic fillings caused by cutting muPVC pipe must not be allowed to be drawn into the combustion air blower. Prevent dust entering the air intake when cutting on building sites. Blower failure which is determined to be caused by plastic fillings or other debris will not be covered by guarantee.

### INSTALLING FLUE AND AIR PIPES ONTO THE TWIN FLUE BOX

Important - When installing the boiler on an existing system a new flue and air intake system **MUST** also be installed. You **MUST NOT** re-use existing flue or air pipework components.

- Remove the twin flue box from Pack 2b supplied with the boiler.
- Remove boiler front panel - Frame 45
- Position flue box on top of the boiler (see diagram)
- Clamp onto boiler using horseshoe clamp provided in boiler packaging box.
- Fix box to the boiler top panel using 6 x M5 screws provided.
- Measure, cut and check the air and flue pipes to pass to the exit from the wall(s) or ceiling.
- Always thoroughly deburr all pipes and most important, remove shavings from within the pipe.
- Assemble, using solvent weld cement, the pipework from the boiler connections to the exit from the first wall/ceiling, (remount the boiler if removed). When pushing pipe through walls, ensure grit and dust is not allowed to enter the pipe.

**Ensure pipes are fully engaged into sockets and solvent welded with no leaks.**

- Using the same methods drill any further holes (always covering existing pipework), cut and assemble the pipework.
- From outside, complete the two terminations - See Frame 9 Flue System and make good all holes. (Wall sealing collars are available to make good hole areas on the wall face (part number C.08.0.00.07.0).
- **Support any pipes whose route could be displaced either of its own accord or by accident. Any horizontal run over 1m or vertical runs of any length must always be supported. Brackets should be placed at intervals of approximately 1m. Brackets should be loose enough on the pipe to allow thermal expansion and contraction movement.**
- **Flue pipework through walls MUST be sleeved to allow thermal expansion and contraction movement.**
- Check all connections for security and re-seal any joints using solvent cement where soundness may be in doubt.

**Note.** It is equally important to seal the air inlet with solvent cement as the flue outlet pipe joints.

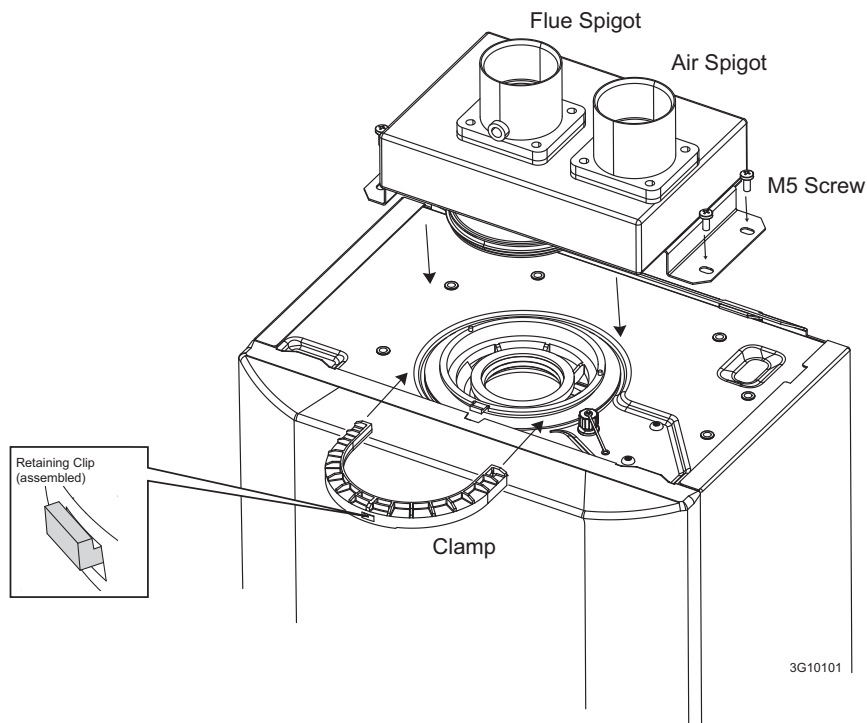

# INSTALLATION

## 17 DETERMINING THE FLUE LENGTH AND FLUE PACKS REQUIRED FOR CONCENTRIC OPTION KIT

Where a concentric flue option is chosen the following instruction should be followed and the standard flue in flue box omitted.

**IMPORTANT.** The boiler MUST be installed in a vertical position

Only use Keston concentric flue pipe and fittings.

### FLUE KITS

**Pack B** - telescopic supplied as an optional extra

**Concentric Flue Screw Retaining Kit** - optional kit for mechanical fixing of flue joints.

**Finishing Kit** - Supplied as an optional extra.

Refer to 'Flue Extension Ducts'

**Dimension X** - Wall thickness.

**Dimension L** - Wall thickness plus boiler spacing.

**Dimension S** - Optional stand-off frame depth 45mm.

**MAXIMUM HORIZONTAL FLUE LENGTH = 575MM**

**MINIMUM HORIZONTAL FLUE LENGTHS - TELESCOPIC TERMINAL = 350MM**

(Centre Line of turret to outside of wall terminal)

1. If the telescopic B pack is used, they may be mounted horizontally. The 1.5 degrees is taken care of by the inclination of the flue within the air pipe.
2. Only use water as a lubricant during assembly.

Total Flue length dimension (measuring from CL of turret to outside wall)	
Rear flue dim. X+155	Side flue dim. L+197
Up to 575 mm	Up to 575 mm

REAR FLUE

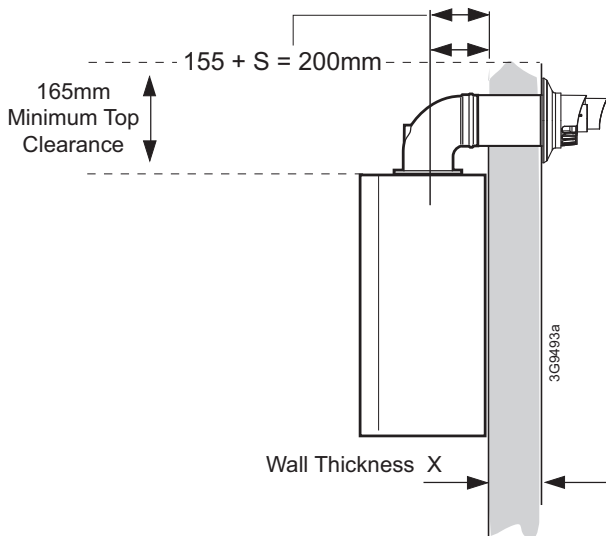

SIDE FLUE

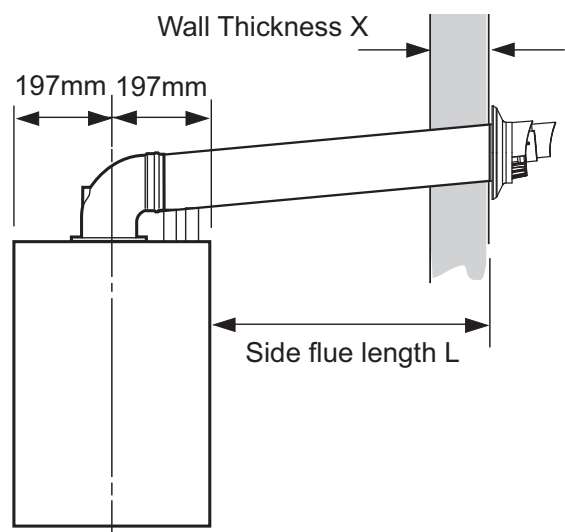

**Note: All other clearances as per Twin Flue Application (See Frame1)**

# INSTALLATION

## 18 TERMINAL WALL SEAL ASSEMBLY / POSITIONING - CONCENTRIC FLUE OPTION

Prior to fitting the flue, the rubber terminal wall seal provided in the flue pack MUST be fitted to the flue terminal as shown below in Figure 1.

Once the flue is installed it is IMPORTANT that the rubber terminal wall seal is pressed against the outside wall to create an adequate seal between the flue and wall as shown in Figure 2.

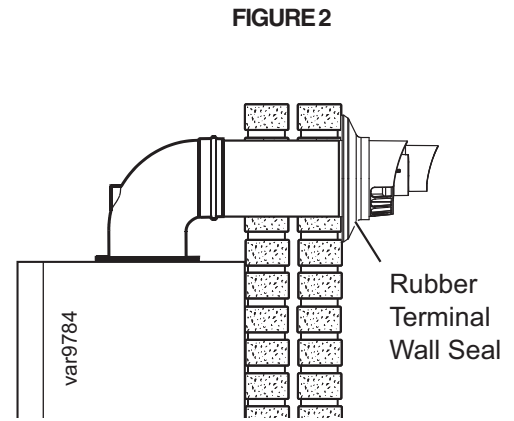
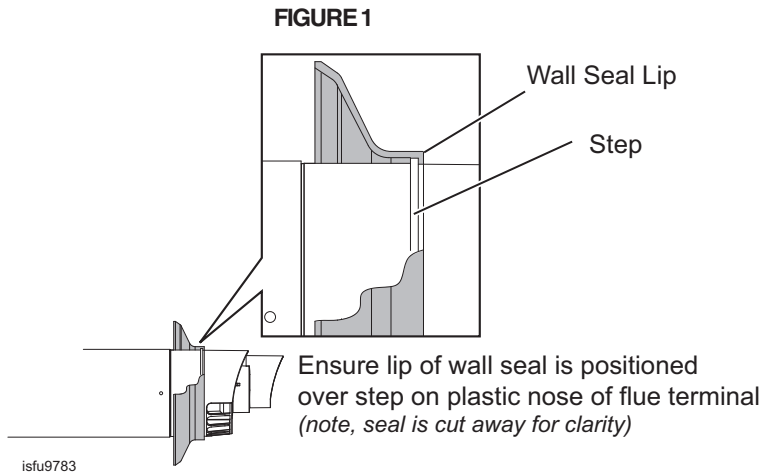

## 19 FLUE ASSEMBLY - CONCENTRIC FLUE OPTION - Exploded View

An optional flue duct extension kit is required for wall thicknesses greater than :

**Side** 378mm

**Rear** 420mm

### LEGEND

1. Duct assembly.
2. Flue turret.
3. Turret clamp.

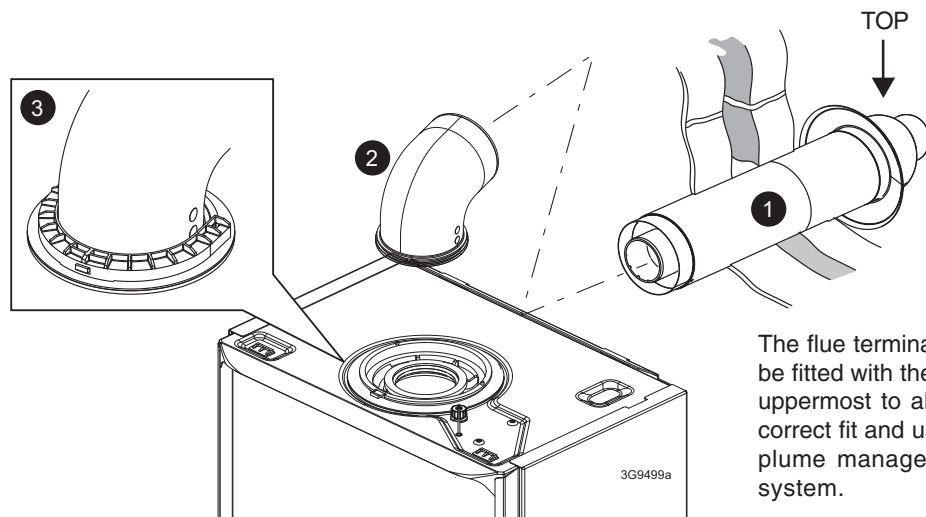

The flue terminal MUST be fitted with the 'TOP' uppermost to allow the correct fit and use of the plume management system.

# INSTALLATION

## 20 WALL MOUNTING TEMPLATE - CONCENTRIC FLUE OPTION

The wall mounting template is located on the internal protective packaging.

**Note.**

The template shows the positions of the fixing holes and the position that the twin flue box is located. Care **MUST** be taken to ensure the correct holes are drilled.

1. Tape template into the selected position. Ensure squareness by hanging a plumbline as shown.
2. Mark onto the wall the following:
  - a The wall mounting plate screw positions (choose one from each group).
  - b The position of the air and flue when exiting straight out of the wall where the boiler is mounted.

**Note.** Mark the centre of the hole as well as the circumference.

3. Remove the template from the wall.

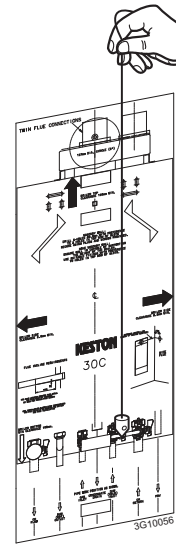

## 21 PREPARING THE WALL - CONCENTRIC FLUE OPTION

**IMPORTANT.**

Ensure that, during the cutting operation, masonry falling outside of the building does not cause damage or personal injury.

1. Cut the flue hole (preferably with 5" core bore tool for concentric), ensuring that the hole is square to the wall. Both wall faces immediately round the cut hole should be flat.
2. Drill 2 holes with a 7.5mm / 8mm masonry drill and insert the plastic plugs, provided, for the wall mounting plate.
3. Locate 2 No.14 x 50mm screws in the wall mounting plate (one at each side, in any of the 3 holes provided at each side) and screw home.

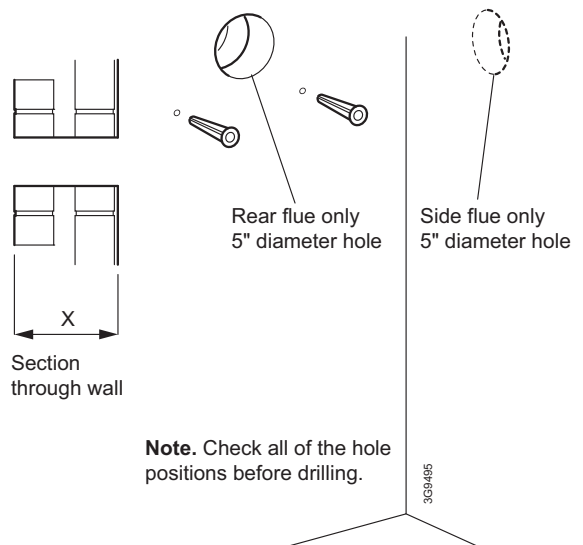

FLUE OUTLET



# INSTALLATION

## 22 SETTING THE FLUE - REAR - CONCENTRIC FLUE OPTION

### TELESCOPIC FLUE - Wall thickness of 195mm to 420mm

#### Notes.

a. If the stand-off frame is used it is essential to add 45mm to 'X' the measured wall thickness when marking the flue (this will allow for the fitted frame).

1. Measure and note wall thickness X. Refer to Frame 17.
2. Add 75mm to dimension X and set telescopic flue length as indicated in drawing.
3. Using a 3.5mm drill bit, drill one hole in outer air duct taking care not to pierce plastic inner flue.
4. Fix to length using self tappers provided.
5. Seal outer air duct using the tape provided.

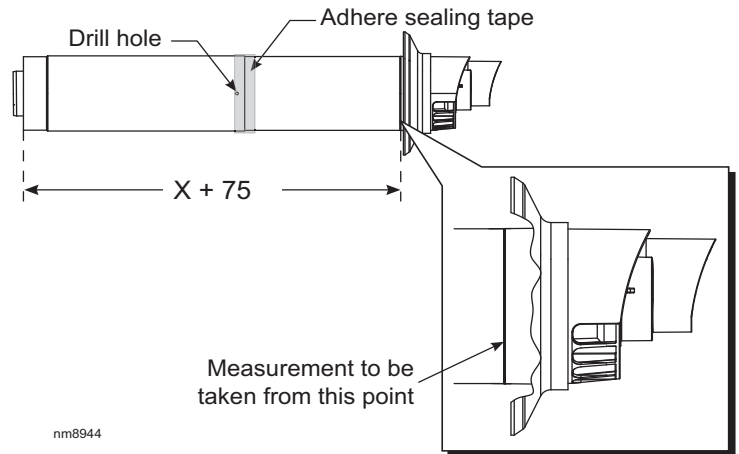

## 23 SETTING THE FLUE - SIDE - CONCENTRIC FLUE OPTION

### TELESCOPIC FLUE - Wall thickness of 150mm to 375mm

1. Measure and note wall thickness X. Refer to Frame 17.
2. Measure distance from side of boiler to inside of wall and add to wall thickness  $X=L$ . Refer to Frame 17.
3. Add 115mm to dimension L and set telescopic flue length as indicated in drawing.
4. Using a 3.5mm drill bit, drill one hole in outer air duct taking care not to pierce plastic inner flue.
5. Fix to length using self tappers provided.
6. Seal outer air duct using the tape provided.

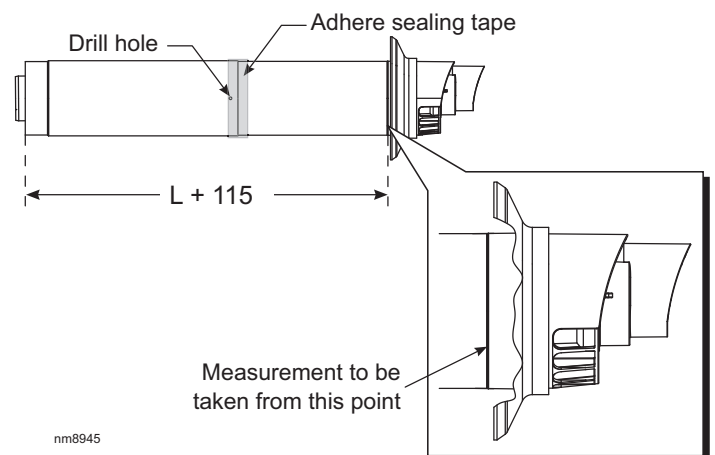

# INSTALLATION

## 24 CONDENSATE PIPE TERMINATION CONFIGURATIONS

Notes: ALL EXTERNAL PIPE RUNS MUST BE IN ACCORDANCE WITH BS 6798

### 1. INTERNAL TO SINK WASTE UPSTREAM OF SINK WASTE TRAP

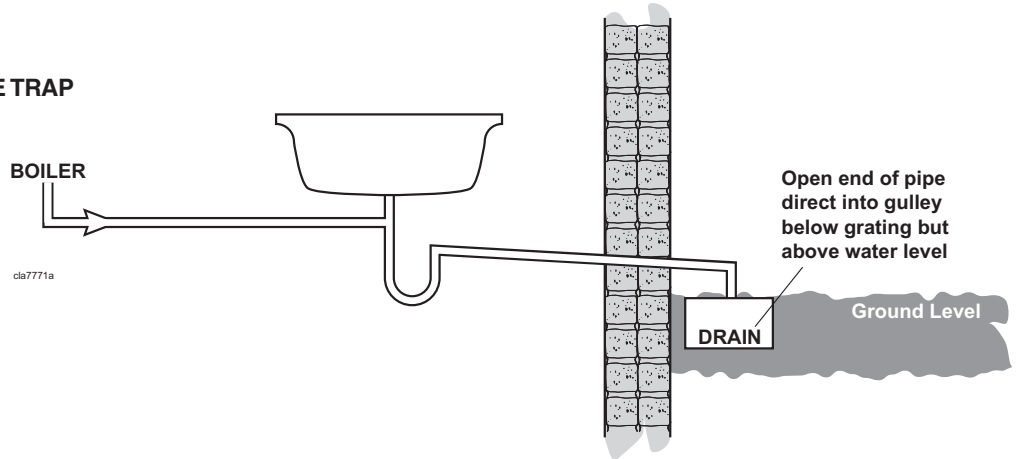

### 2. INTERNAL CONNECTION TO SOIL AND VENT STACK

\* Make connection to SVP using a solvent welded saddle

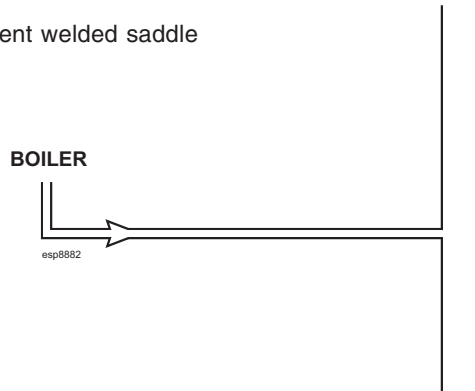

### 3. TERMINATION TO SOAK AWAY

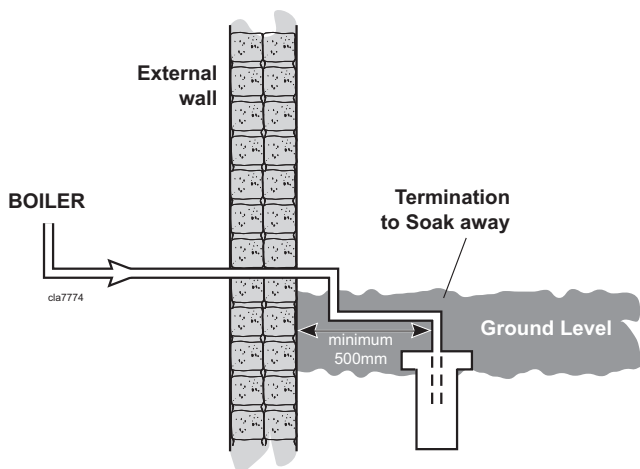

### 4. TERMINATION TO DRAIN / GULLY

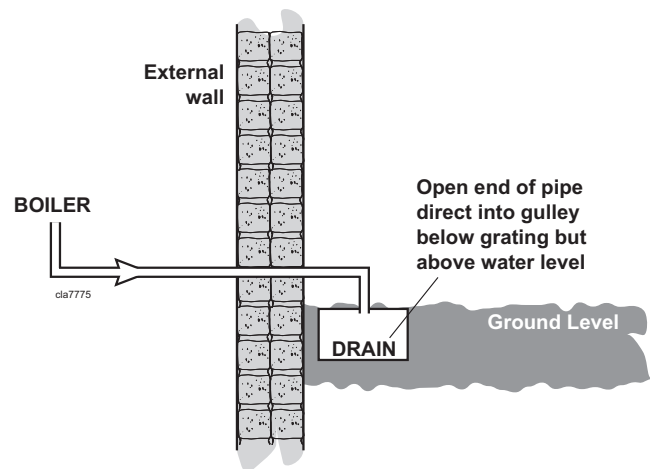

# INSTALLATION

## 25 CONNECTING THE CONCENTRIC FLUE OPTION TO THE BOILER

### Notes.

- Before fitting the flue turret fill the condensate trap within the boiler by pouring a cupful of water into the flue outlet (shown below). Take care to ensure that the water is only poured into the flue outlet, and does not spill into the boiler casing.
- During assembly check that flue seals do not become dislodged.

### NOTE. SIDE FLUE

Select flue orientation before inserting turret into boiler manifold.

DO NOT twist the turret once inserted.

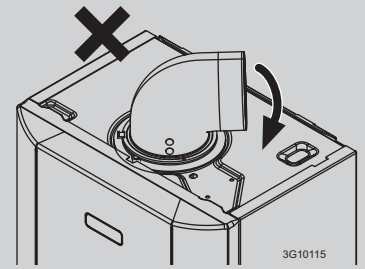

1. Ensure front panel is removed.
2. Locate the flue into the turret.
3. Insert the flue assembly through the prepared hole in the wall. Push through and pull back to seal against outside wall face.
4. Locate the flue turret into the flue manifold and secure by applying downward pressure.
5. Engage the clamp in its slide mechanism and push it horizontally backwards.
6. Locate BOTH plastic pegs BEFORE the front retaining clip is fully located.

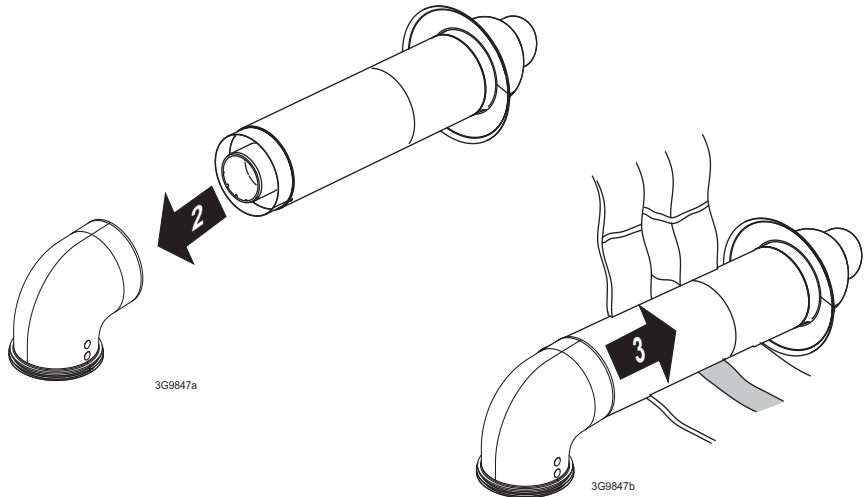

### Note - Flues over 1 metre long

It is recommended that a support bracket is fitted for every 1 metre of extension pipe used and a bracket should be used at every joint, to ensure pipes are held at the correct angle.

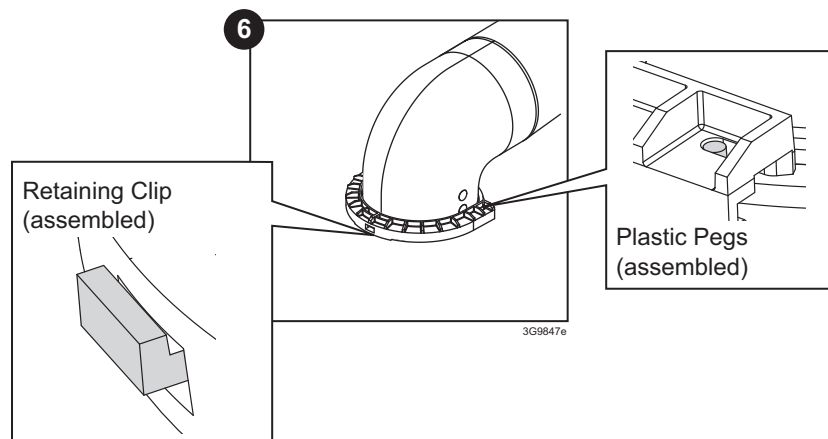
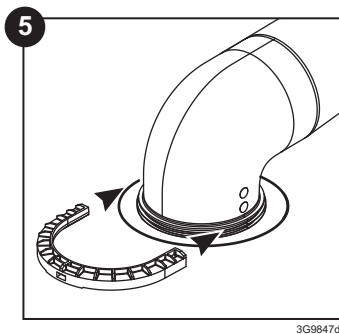
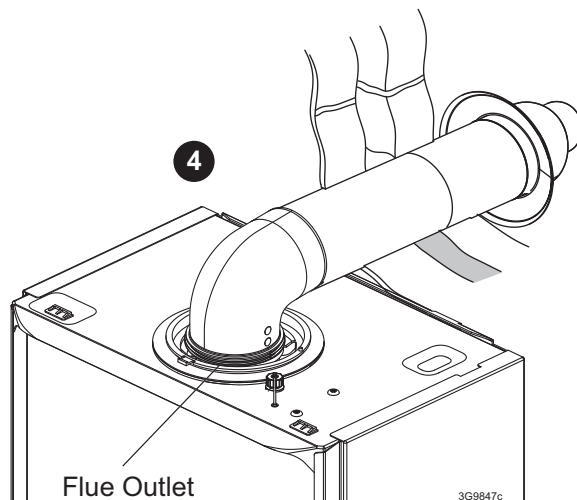

# INSTALLATION

## 26 WATER CONNECTIONS - CH

### NOTES.

Ensure all boss blanking plugs are removed before connecting hardware. Each valve must be fitted to the correct boss as shown in the picture.

Ensure each union is fitted with fibre seals provided.

Do not subject any of the isolating valves to heat as the seals may be damaged.

1. Connect the CH flow service valve and copper tail provided in the hardware pack to the threaded boss connection provided at the lower rear of the boiler.
2. Connect the CH return valve (black handle) and copper tail.
3. If connecting the boiler to heating loads in excess of 60,000 Btu/h, connecting flow and return heating system pipework must be sized in 28mm diameter at the point of pipe connection to the boiler tails. Use 22mm x 28mm pipe adaptors as appropriate.

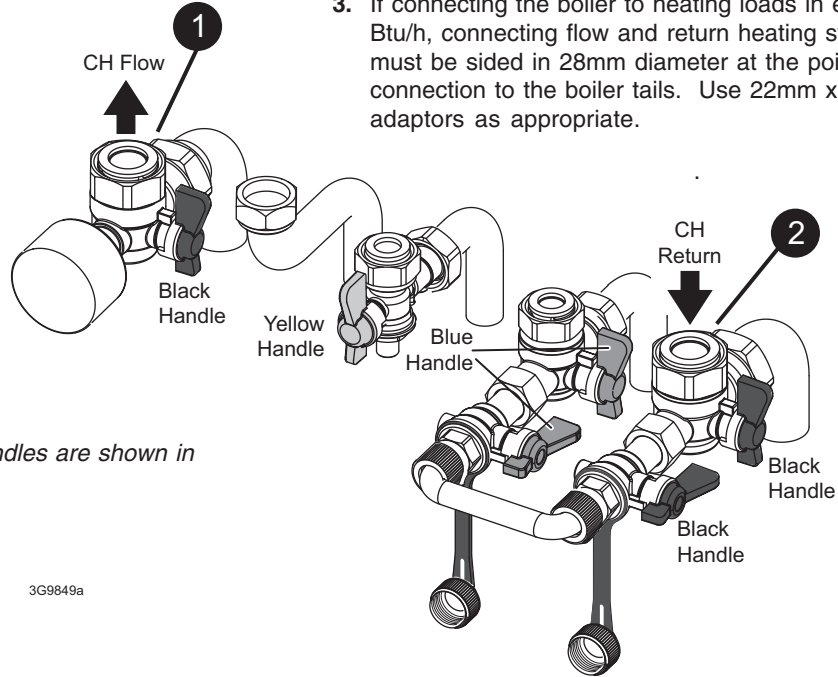

Note that all isolation handles are shown in the open position.

## 27 WATER CONNECTIONS - DHW

1. Fit the DHW inlet service valve (blue handle) and copper tail to the threaded boss connection ensuring the seal provided is correctly located.
2. Fit DHW outlet pipe tail to DHW outlet connection, ensuring the seal provided is correctly located.
3. Fit the filling loop provided between the DHW inlet valve and the CH return valve.

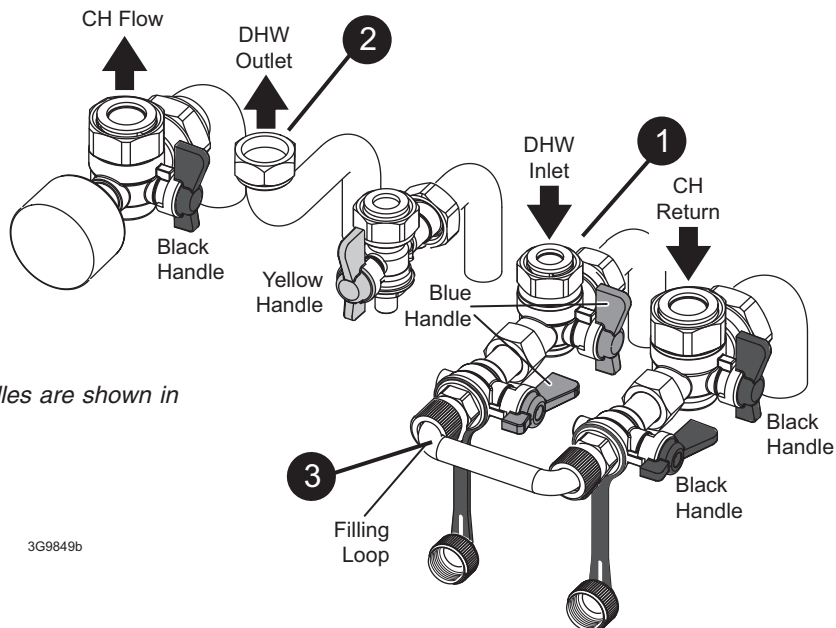

Note that all isolation handles are shown in the open position.

## 28 GAS CONNECTION

**IMPORTANT.** The gas service cock is sealed with a non-metallic blue fibre washer, which must not be overheated when making capillary connections. Refer to Frame 1 for details of the position of the gas connection.

For additional gas supply information refer to "Gas Supply" on page 8.

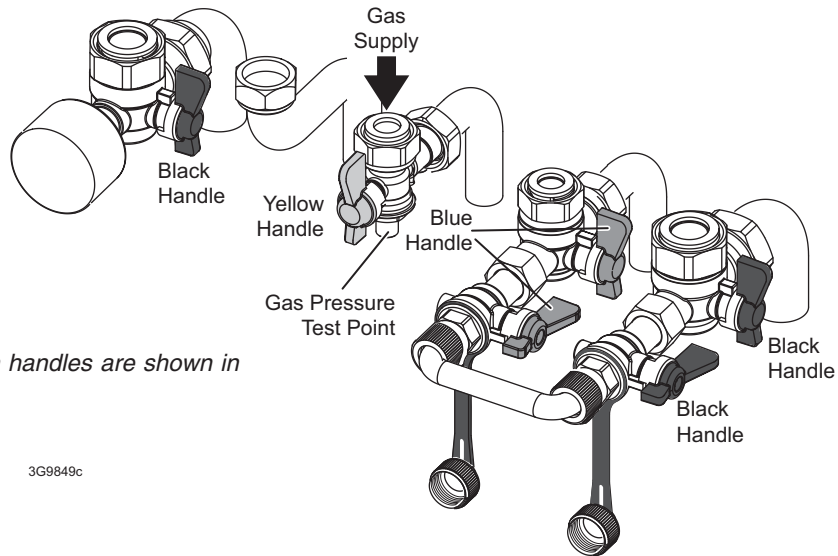

*Note that all isolation handles are shown in the open position.*

3G9849c

## 29 SAFETY VALVE DRAIN

The safety valve connection, located at the bottom right-hand side of the boiler, comprises a 15mm diameter stub pipe.

The discharge pipe should be positioned so that the discharge of water or steam cannot create a hazard to the occupants of the premises or damage the electrical components and wiring.

A purpose made safety valve drain pipe is provided with the boiler to allow safe discharge through a wall to the outside of the building. This is particularly relevant to 'high rise' installations but can be used for all installations.

*Note that all isolation handles are shown in the open position.*

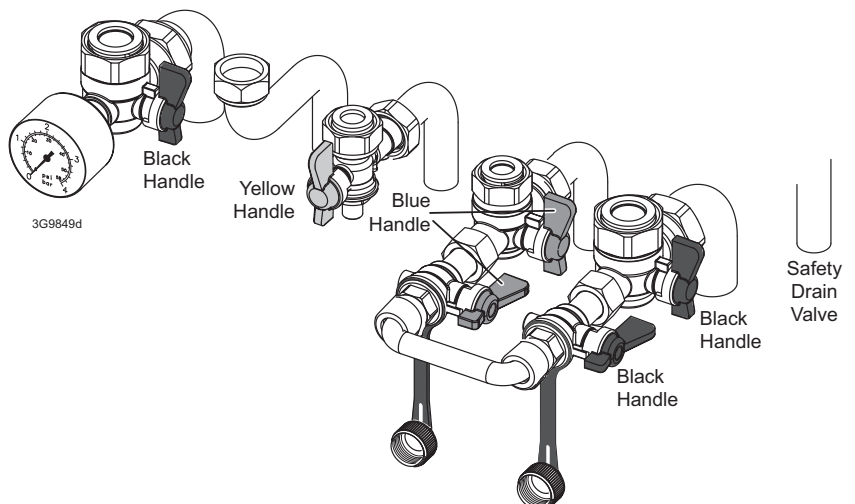
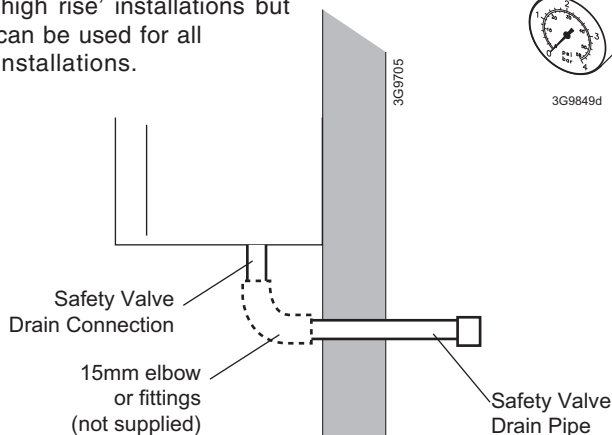

# INSTALLATION

## 30 FILLING

### IMPORTANT - when filling:

When filling, there may be a slight water leak from the air vent therefore electrical connections should be protected.

**Note.** The domestic hot water flow rate is automatically regulated to a maximum of 12.4 l/m (2.8 gpm).

1. Ensure Filling Loop is connected
2. Ensure dust cap on auto air vent is slackened off (refer to Frame 68).
3. Check all isolation handles are in the open position

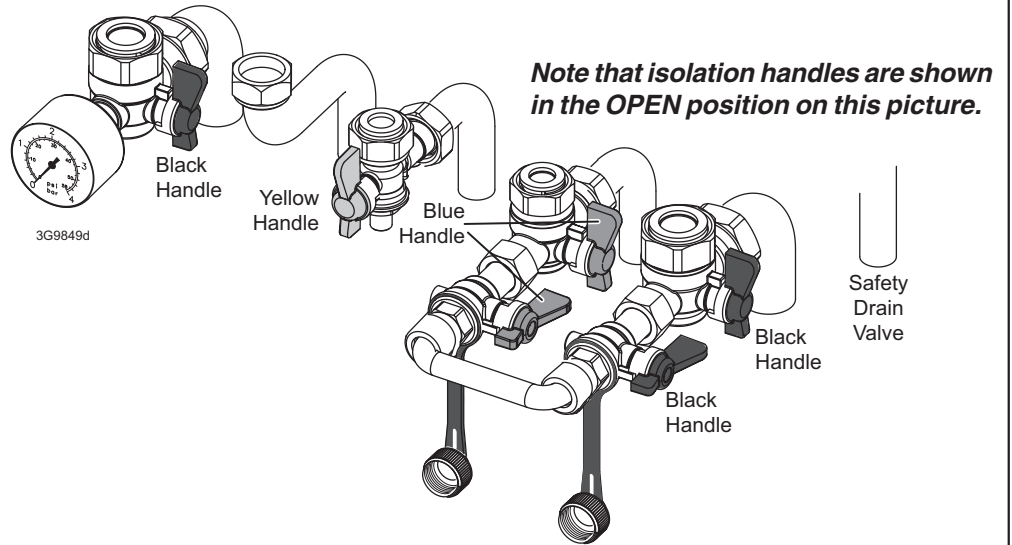

4. Once pressure gauge dial reads between 1 - 1.5 bar turn the filling loop isolation valves back to the closed position.

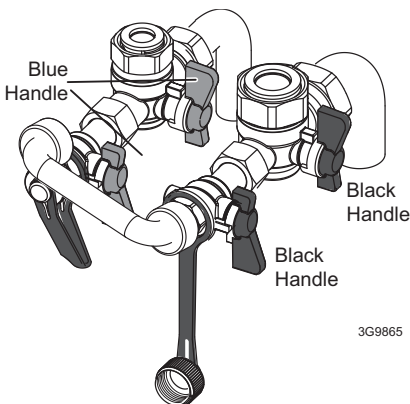
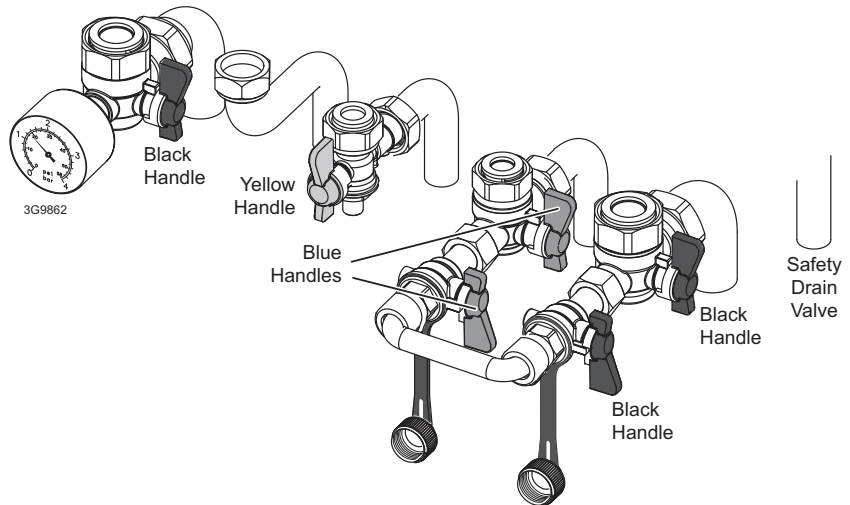

5. Disconnect filling loop at the LH side, ensuring washer is retained and screw on cap.

**Note.** Fully open all DHW taps and ensure water is flowing freely. Once satisfied close all taps.

## 31 ELECTRICAL CONNECTIONS

**WARNING.** This appliance MUST be earthed.

A mains supply of 230Vac ~ 50 Hz is required.

The fuse rating should be 3A. All external controls and wiring must be suitable for mains voltage.

Wiring external to the boiler MUST be in accordance with the current I.E.E. (BS.7671) Wiring Regulations and any local regulations.

Wiring should be 3 core PVC insulated cable, not less than 0.75mm<sup>2</sup> (24 x 0.2mm), and to BS 6500 Table 16. For IE reference should be made to the current ETCI rules for electrical installations.

Connection must be made in a way that allows complete isolation of the electrical supply such as a double pole switch having a 3mm (1/8") contact separation in both poles. The means of isolation must be accessible to the user after installation.

## 32 INTERNAL WIRING

The Keston 30C boiler comes pre-fitted with 1.8m of mains cable. This must be connected to a permanent live supply and NOT switched by thermostats/programmers. For installers wishing to change this cable refer to Frame 33.

The Keston 30C boiler comes pre-fitted with a link wire between the room thermostat/Timer connections on the terminal strip. This creates a permanent call for heat and must be removed when adding a room thermostat/programmer.

The terminal block cover carries two spare fuses for the main PCB.

To add thermostat/programmer:

1. Isolate the mains supply to the boiler.
2. Remove the front panel. Refer to Frame 44.
3. Swing the control box down into the servicing position. Refer to Frame 50.
4. Route incoming cables through the grommets in bottom panel (note, grommets are 'blind' and will require puncturing) and secure using clamps and screws provided in hardware pack.
5. Pull off rubber terminal block cover.
6. Connect wires to terminal block, as shown below
7. Re-assemble in reverse order.

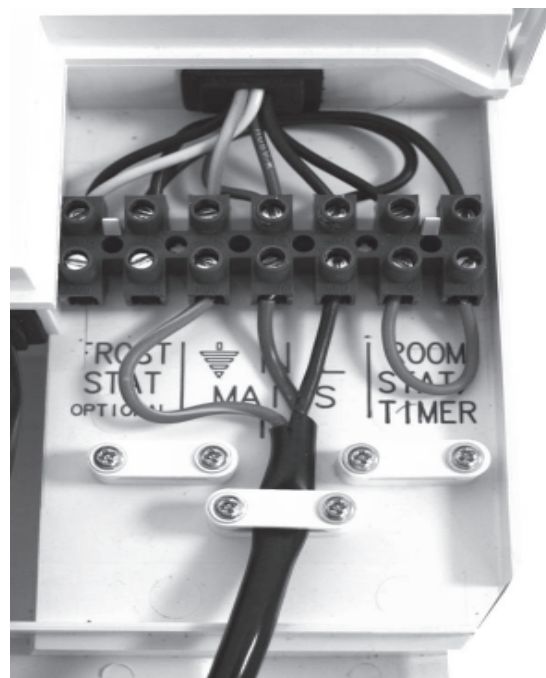
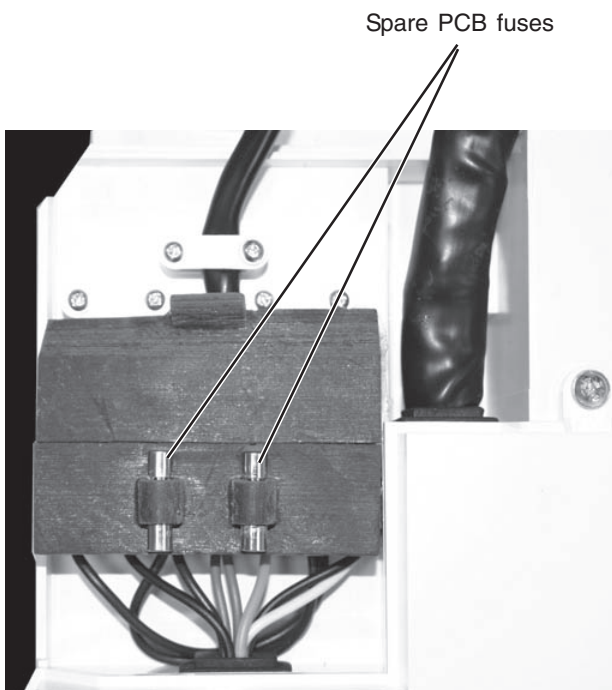

*continued . . . .*

## 32 INTERNAL WIRING... CONT'D

Keston offer 2 kits as follows:  
(see individual kits for installation instructions)

**Electronic Timer (7 day) kit** - 7 day electronic CH timer fits into the control box of the boiler. This can be fitted in conjunction with a room thermostat. Features English language installation help messages.

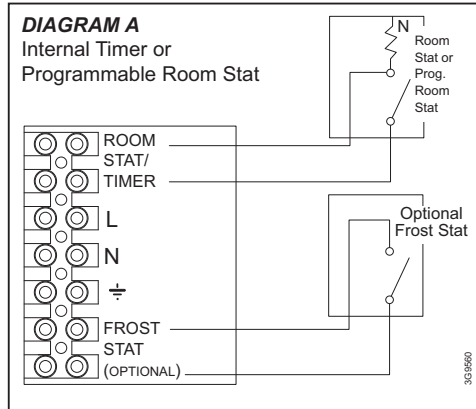

**(1) ROOM THERMOSTAT WITH INTERNAL BOILER TIMER OR  
(2) PROGRAMMABLE ROOM THERMOSTAT**

1. Remove link wire between room stat/timer terminals.
2. Connect room stat across terminals as shown in diagram A
3. If room stat has a neutral connection, connect this to terminal N (load) in the fused spur.

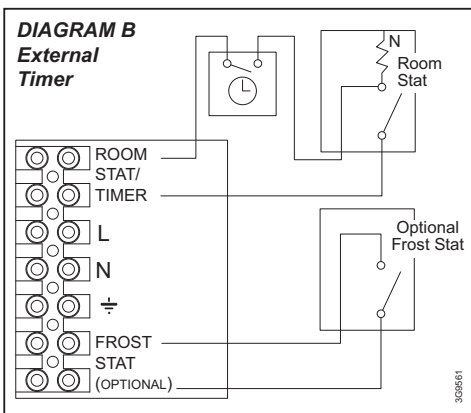

**ROOM THERMOSTAT + TIMER**

1. Remove link wire between room stat/timer terminals.
2. Connect room stat and programmer in series as shown in diagram B.
3. If room stat has a neutral connection, connect this to terminal N (load) in the fused spur.

**FROST THERMOSTAT**

If parts of the system are vulnerable to freezing or the programmer is likely to be left off during cold weather, a frost stat should be fitted in conjunction with a pipe thermostat.

1. Position the frost thermostat in a suitable position, i.e. area vulnerable to freezing.
2. Connect frost stat across terminals marked frost stat shown in diagrams A & B.

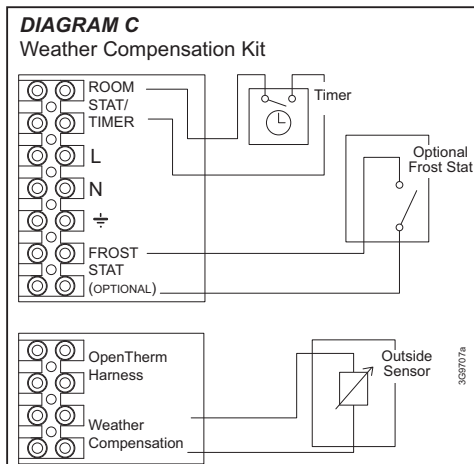

**WEATHER COMPENSATION KIT**

The two wires from the weather compensation kit (outside sensor), must be connected into the two right hand terminals as shown in diagram C.



## 33 REPLACING PRE-FITTED MAINS CABLE

If it is necessary to use an alternative mains cable to the one pre-fitted then use the following guide.

Replacement wiring should comply with notes in Frame 31.

1. Isolate the mains supply to the boiler.
2. Remove the front panel. Refer to Frame 44.
3. Swing the control box down into the service position. Refer to frame 50.
4. Remove the live, neutral and earth wires from the terminal block.
5. Loosen the cable clamp and withdraw the mains cable.
6. Route replacement cable back through the cable clamp and grommet and re-tighten to provide cord anchorage.
7. Connect the live, neutral and earth wires to the terminal strip.

When making the mains electrical connections to the boiler it is important that the wires are prepared in such a way that the earth conductor is longer than the current carrying conductors, such that if the cord anchorage should slip, the current carrying conductors become taut before the earthing conductor.

8. Swing the control box back up into the operating position and re-fit the front panel ensuring a good seal is made.

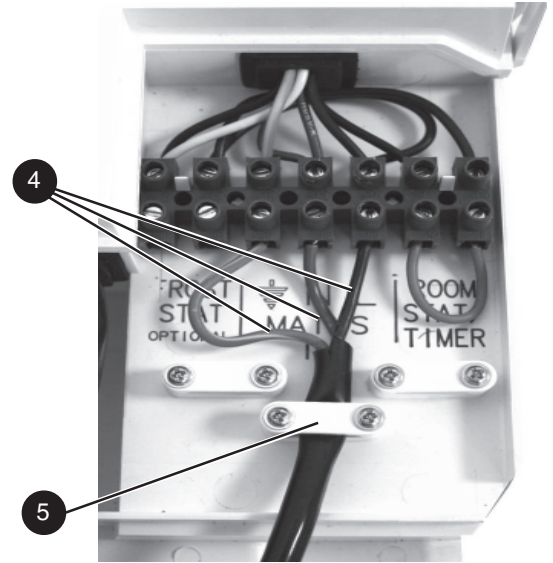

## 34 FITTING THE WEATHER COMPENSATION KIT - SUPPLIED AS STANDARD

This kit provides the facility to apply outside air temperature control to the boiler water flow temperature which provides energy savings. The outside sensor provided measures outside air temperature and sends a signal to the boiler, which adjusts the maximum boiler flow temperature in response. If outside air temperature is greater than the system design temperature, the boiler flow temperature is reduced providing running cost savings. The boiler will operate in the condensing mode more frequently increasing savings.

Once the sensor is fitted it is automatically detected.

The sensor operation may be configured by adjustment of the boiler operating parameters, if necessary.

### Kit Contents

- A. Outside Air Sensor

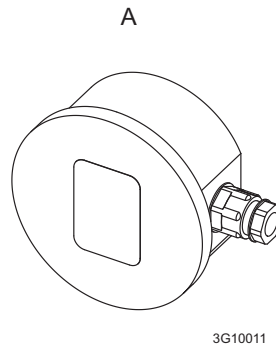

# INSTALLATION

## 35 FITTING THE KIT

**Note.** A timer should be fitted to the system so that CH will be switched off when appropriate.

### Fitting the sensor

The air sensor should be located on an external wall of the building to be heated. Fix the sensor to a north/north-east facing wall to avoid direct radiation from the sun. The air sensor should be located to avoid any heating effect from the boiler flue.

To fix the air sensor to the wall, unscrew the sensor box plastic cover and screw/plug the sensor body to the wall.

Wire a twin core 0.5mm<sup>2</sup> cable from the sensor to the boiler through an RH grommet located on the underside of the boiler. Cable length between sensor and boiler should be no greater than 20m. Note that this connection is safety extra low voltage. It is not necessary for the person carrying out the wiring to be approved to Part P of the Building Regulations.

Avoid running this cable alongside mains voltage cables.

### Wiring the Weather Compensation Kit to the Keston 30C.

1. Isolate the electricity supply to the boiler.
2. Remove the boiler front panel (refer to boiler installation instructions).
3. Hinge down the control box.
4. Connect the sensor wiring into the RHS of the 4 way terminal block and secure with a cable clamp.
5. Re-assemble in reverse order.

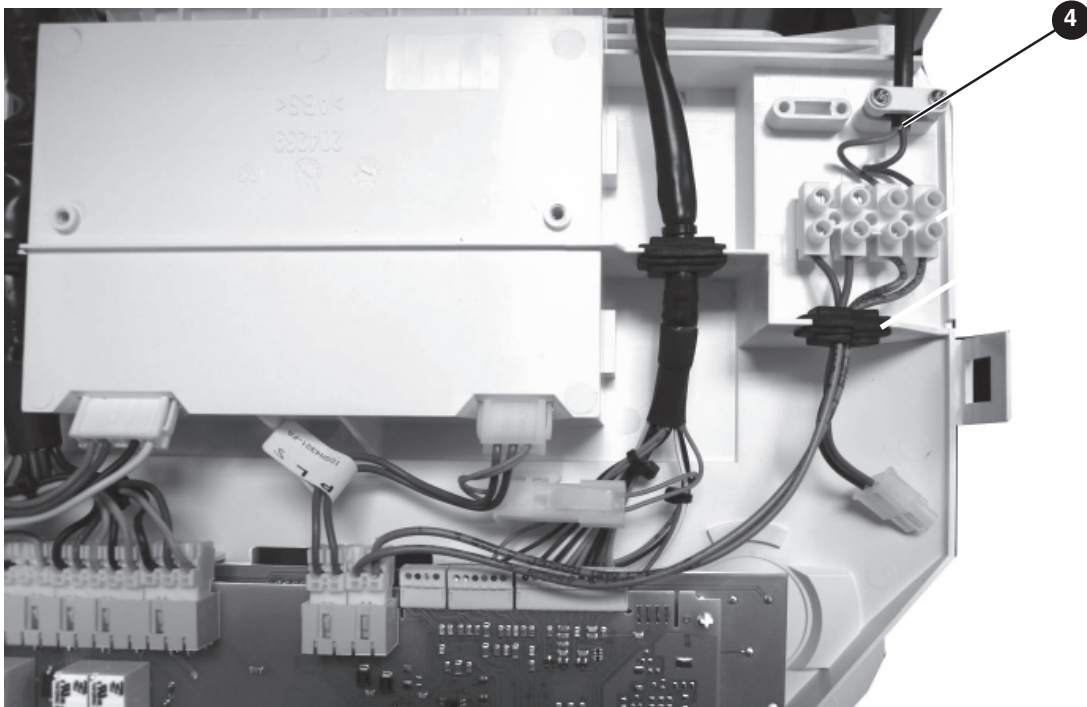

## 36 CH OPERATION

The On and Off time control of central heating should be controlled by a separate timer. This can be a standard unit or either of the options available from Keston 30C range.

During programmed On times the Central Heating Radiator Flow Temperature is controlled by the boiler relative to the Outside Temperature as shown in the following diagram.

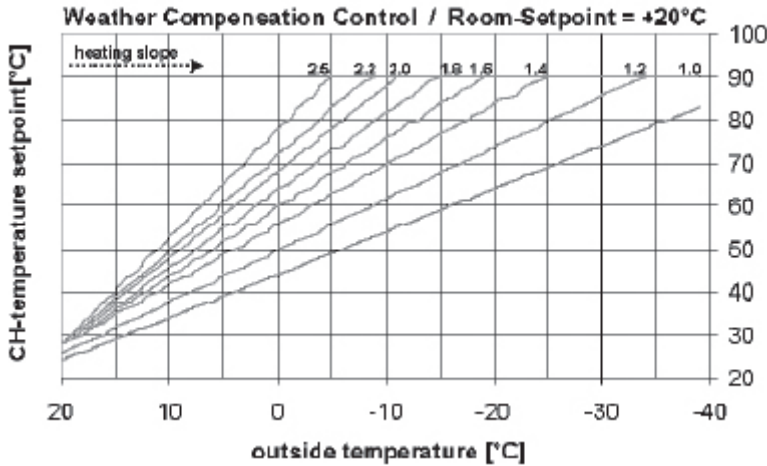

The Room temperature can be adjusted using the Central Heating Temperature Control Knob on the boiler as follows. Essentially rotating the knob clockwise increases the room temperature and rotating the knob anti-clockwise decreases the room temperature.

If the Central Heating Temperature Control Knob is rotated fully clockwise then for an Outside Temperature of 15°C a Flow Temperature of 40°C will be provided. For an Outside Temperature of 0°C a Flow Temperature of 78°C will be provided with the relationship varying lineally in between these 2 points (line on the graph 2.5)

If the Central Heating Temperature Control Knob is in its mid position then for an Outside Temperature of 15°C a Flow Temperature of 36°C will be provided. For an Outside Temperature of 0°C a Flow Temperature of 65°C will be provided with the relationship varying lineally in between these 2 points (line on the graph between 1.6 and 1.8)

If the Central Heating Temperature Control Knob is rotated fully anti-clockwise then for an Outside Temperature of 15°C a Flow Temperature of 30°C will be provided. For an Outside Temperature of 0°C a Flow Temperature of 44°C will be provided with the relationship varying lineally in between these 2 points (line on the graph 1.0)

## 37 EXTERNAL ELECTRICAL CONTROLS

### Wiring External to the Boiler

The fuse rating should be 3A.

Wiring external to the boiler **MUST** be in accordance with the current I.E.E. (BS.7671) Wiring Regulations and any local regulations.

### Frost Protection

If parts of the pipework run outside the house or if the boiler will be left off for more than a day or so then a frost thermostat should be wired into the system.

This is usually done at the programmer, in which case the programmer selector switches are set to OFF and all the other controls **MUST** be left in the running position.

The frost thermostat should be sited in a cold place but where it can sense heat from the system.

**Note.** *If the boiler is installed in a garage it may be necessary to fit a pipe thermostat, preferably on the return pipework.*

**Earths are not shown for clarity but must never be omitted.**

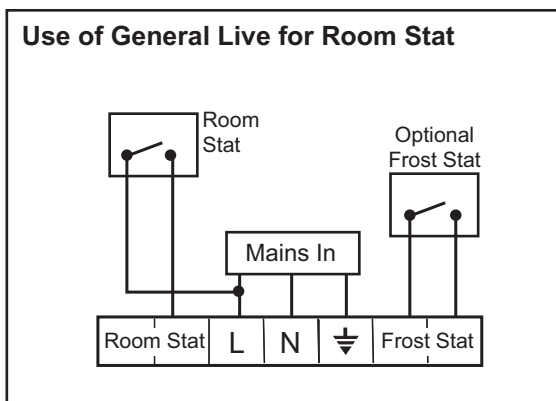
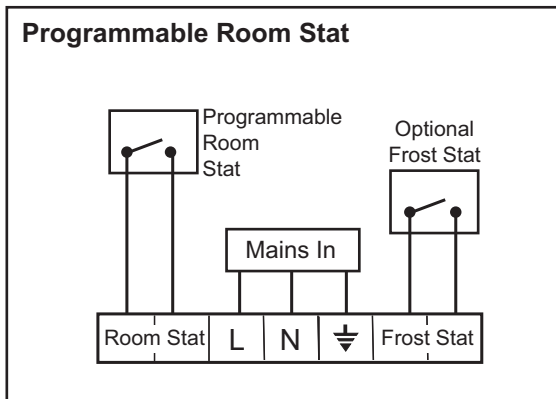

3G9990a

### OpenTherm Programmable Room Temperature Control

**Note.** *These terminals **MUST ONLY** be connected to an OpenTherm Controller, (such as the Keston Chronotherm Room Controller (c.17.4.21.00.0)). Connecting any other device / control wiring may destroy the primary PCB.*

1. Isolate the mains supply to the boiler.
2. Remove the front panel. Refer to Frame 44.
3. Swing the control box down into the servicing position. Refer to Frame 50.
4. Remove the control box cover. Refer to Frame 62, no's 3 and 4.
5. Unclip the 3 way in-line connector containing 2 purple wires and 2 red wires.
6. Connect this 3 way connector to the 3 way connector containing 2 purple wires wired from the 4 way terminal block.
7. Connect the two wires from the OpenTherm Programmable Room Temperature Control to the two LH connections of the terminal block as shown.
8. Re-assemble in reverse order.

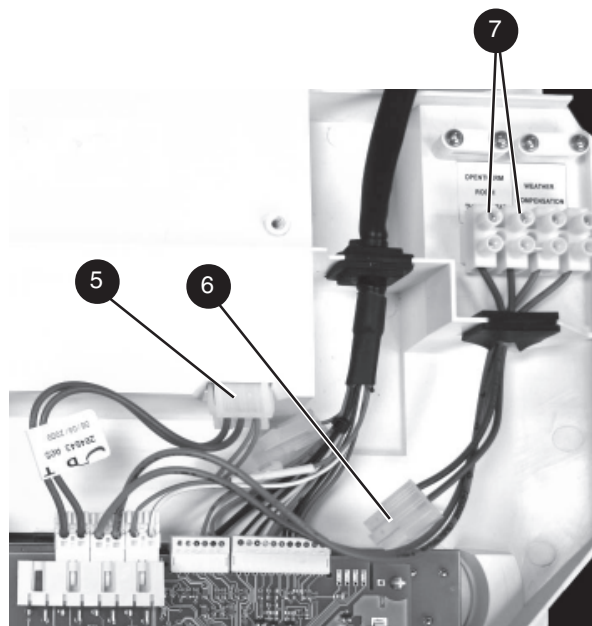



## 39 COMMISSIONING AND TESTING

### A. Electrical Installation

1. Checks to ensure electrical safety should be carried out by a competent person.
2. ALWAYS carry out the preliminary electrical system checks, i.e. earth continuity, polarity, resistance to earth and short circuit, using a suitable test meter.

### B. Gas Installation

1. The whole of the gas installation, including the meter, should be inspected and tested for tightness and purged in accordance with the recommendations of BS. 6891. In IE refer to IS.813:2002.
2. Purge air from the gas installation by the approved methods only.

**WARNING.** Whilst effecting the required gas tightness test and purging air from the gas installation, open all windows and doors, extinguish naked lights and **DO NOT SMOKE.**

### GENERAL

**Please Note:** The combustion for this appliance has been checked, adjusted and preset at the factory for operation on the gas type defined on the appliance data plate. No measurement of the combustion is necessary. **DO NOT** adjust the air/gas ratio valve.

Having checked:

- That the boiler has been installed in accordance with these instructions.
- The integrity of the flue system and the flue seals, as described in the Flue Installation section.

Proceed to put the boiler into operation as follows:

### CHECK THE OPERATIONAL (WORKING) GAS INLET PRESSURE

Set up the boiler to operate at maximum rate by opening hot tap to maximum flow.

With the boiler operating in the maximum rate condition check that the operational (working) gas pressure at the inlet gas pressure test point complies with the requirements - refer to "Gas Supply" on page 8.

Ensure that this inlet pressure can be obtained with all other gas appliances in the property working.

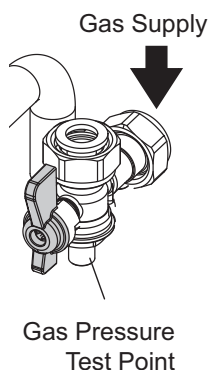

## 40 INITIAL LIGHTING

### Legend

- A. Pre-heat On/off
- B. DHW temperature control
- C. CH temperature control
- D. Off/Summer/Winter/Reset Control
- E. Boiler Status
- F. Burner 'on' indicator
- G. CH Flow Isolating Valve
- H. Pressure Gauge
- J. Gas Inlet Pressure Test Point
- K. Gas Service Cock
- L. DHW Inlet Valve
- M. CH Return Isolating Valve
- N. DHW Outlet

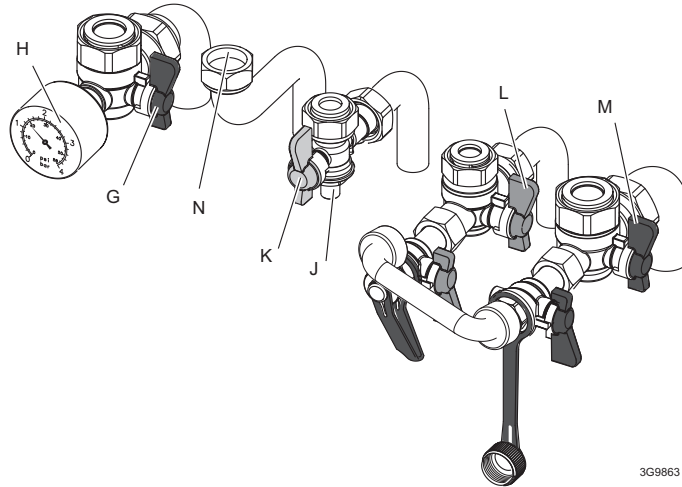
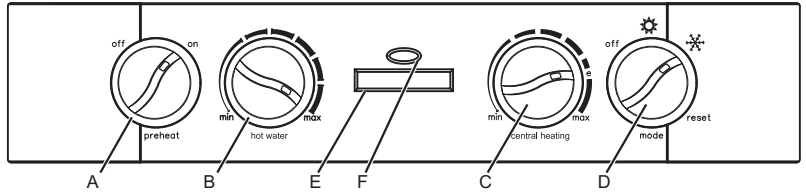

3G9863

1. Check that the system has been filled and that the boiler is not airlocked. Ensure the automatic air vent cap is open. Refer to Frame 30.

### Note.

*It is important the burner is not operated before the system is fully vented of air. If it is necessary to operate the appliance pump to assist venting of the air this must be done with the gas service cock turned off.*

2. Refit the boiler front panel. Refer to Frame 44.
3. Check that the drain cock is closed and that the CH and DHW isolating valves (M, L and G) are OPEN.
4. Check that the electrical supply is OFF.
5. Check that the boiler mode control knob (D) is off.
6. Check that the gas service cock (K) is OPEN.
7. Slacken the screw in the inlet pressure test point (J) and connect a gas pressure gauge via a flexible tube.
8. Switch the electricity supply ON and check all external controls are calling for heat.

### CENTRAL HEATING

9. Set the CH temp control (C) to max and turn the mode control knob (D) to ☼, ensure the timer/room stat are on. The boiler control will now go through its ignition sequence until the burner is established.
10. If the boiler does not light the following messages will be displayed in rotation **“Ignition Lockout” - “1 Check other gas appliances” - “2 Reset boiler” - “3 Contact installer”**. After 5 attempts the boiler will lock out and carry on displaying the messages. Reset the boiler (refer to Frame 40B). The boiler will repeat its ignition sequence. If reset occurs 5 times within 15 minutes then **“Too many resets”** will be shown. If power is removed this will be reset.

When the burner is established the BLUE 'Burner On' neon (F) will be illuminated, the LCD will display **“Central Heating”** and **“Radiator Temp XX°C”**.

### DOMESTIC HOT WATER

11. With the boiler firing, set the DHW Temp Control knob (B) to maximum and fully open a DHW tap.

The boiler will continue to run and the display (E) will show **“Hot Water” - “Temperature XX°C” - “High Efficiency”**.

12. Ensure that with the boiler operating the dynamic gas pressure is able to obtain maximum output. Refer to Table 2.

### IMPORTANT

**The gas input to the burner is regulated by the gas valve according to the air flow produced by the fan. It is NOT user-adjustable. Any interference to sealed settings on the gas valve will adversely affect operation and render our warranty void.**

For additional gas supply information refer to “Gas Supply” on page 8

13. Turn off the DHW tap.

*Note. The temperature displayed “XX°C” is that measured at that moment, not the set temperature.*

*Note. The boiler incorporates a fan overrun cycle which MUST NOT be prematurely interrupted by isolation of the mains electricity supply.*

continued. . . .

# INSTALLATION

## 40 INITIAL LIGHTING . . . . CONT'D

### THE DISPLAY

The user control has one neon and one display to inform the user about the status. The display will show the status of the boiler. The neon will show the status of the flame. If no flame is detected the neon is off. When the flame is detected the neon will be lit permanently.

The display scrolls through a maximum of 3 messages under any operational condition as shown below.

**Notes:** *Boiler frost protection - boiler fires if temperature is below 5° C.  
The temperatures shown below are for illustration purposes only. The measured temperatures will be shown on the boiler.*

### DISPLAY FUNCTIONS IN NORMAL OPERATION

NORMAL OPERATION	MESSAGE 1	MESSAGE 2	MESSAGE 3
Mode knob in standby position and no heat demand	Standby mode	For hot water turn mode knob clockwise	For central heating turn mode knob clockwise twice
Mode knob in summer position and no heat demand	Summer mode	For central heating turn mode knob clockwise	
Mode knob in winter position and no heat demand	Winter mode	Timer or room stat off	
Domestic hot water operation	Hot water	Temperature 64°C	High efficiency
Central heating operation	Central heating	Radiator Temp 80°C	High efficiency
Pre-heat operation	Pre heat	Temperature 59°C	High efficiency
Boiler frost protection	Boiler frost protection	Temperature 5°C	High efficiency
Pump overrun	Pump overrun		
Fan post-purge	Fan post-purge		

3CG9711

*Note. High efficiency will not be shown for central heating operation if the central heating flow temperature knob is set to greater than 73°C.*

### DISPLAY FUNCTIONS - SETTINGS CHANGED

NORMAL OPERATION	MESSAGE 1	MESSAGE 2	MESSAGE 3
Pre-heat knob moved to off position	Pre heat off		
Pre-heat knob moved to on position	Pre heat on		
DHW temperature knob moved	64°C DHW temp	Hot water temperature 64°C	May not be achieved for high flow rates in winter
CH temperature knob moved	80°C CH temp	Maximum radiator temperature 80°C	
Mode knob moved to standby position	Standby mode	Central heating off	Hot water off
Mode knob moved to summer position	Summer mode	Central heating off	Hot water on
Mode knob moved to winter position	Winter mode	Central heating on	Hot water on
Mode knob moved to reset position	Reset		

3CG9712



## 40 INITIAL LIGHTING . . . . CONT'D

### INSTALLER MODE

Installer Mode is entered as follows:

1. Turn the DHW temperature control knob full anti-clockwise.
2. Turn the CH flow temperature control knob full anti-clockwise.
3. Turn and hold the mode knob in the reset position for more than 5 secs and then turn it to the Winter or Summer position.

The boiler will display **"Installer mode"**.

If no faults have occurred the boiler will display **"No faults"**.

If any faults have occurred a list of faults up to a maximum of 10 including the type of fault and how long ago it occurred will be shown in the following format.

MESSAGE 1	MESSAGE 2	MESSAGE 3
LIST OF FAULTS		
Fault 1 (latest fault)	Low water pressure	2 days ago
Fault 2	No water flow lockout	78 days ago
Fault 3	Overheat lockout	384 days ago

The boiler will then display the current values of flow temperature, return temperature, domestic hot water temperature, DHW flow rate and diverter valve position in the following format:

MESSAGE 1
CURRENT VALUES
Flow temp 80°C
Return temp 60°C
DHW temp 64°C
DHW flow rate 8 l/min
Diverter valve DHW position

**Note.**

*If you would like to hold one of the values on the display to watch its behaviour then turn the reset knob to the reset position while it is displayed and hold it there.*

*Finally the display will operate in one of two modes. If there is a fault then more extensive corrective actions will be shown than are usually displayed for the end user. If there is not a fault then the information displayed for current operating states will also be more extensive than is usually displayed for the end-user (pre-purge, ignition and post purge for example).*

*Installer mode automatically ends after 10 mins or by moving the mode knob to the standby position.*

## 40B RESET PROCEDURE

To reset boiler, turn the mode control knob (D) to reset position and immediately turn knob back to required setting. The boiler will repeat the ignition sequence.

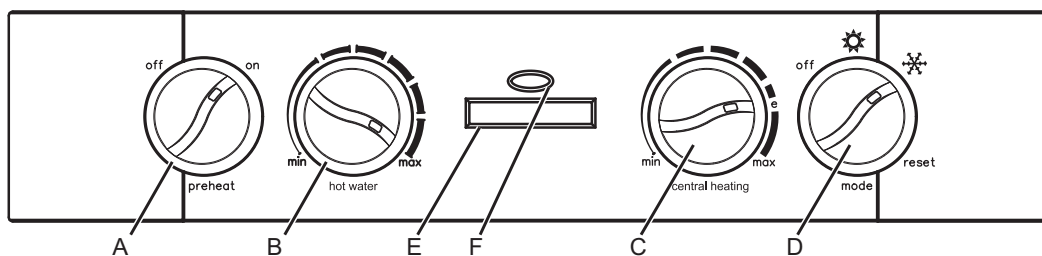

**Legend**

- |                            |                                    |
|----------------------------|------------------------------------|
| A. Pre-heat On/off         | D. Off/Summer/Winter/Reset Control |
| B. DHW temperature control | E. Boiler Status                   |
| C. CH temperature control  | F. Burner 'on' indicator           |

## 41 GENERAL CHECKS

Make the following checks for correct operation in:

### DOMESTIC HOT WATER (DHW) MODE

1. Fully open all DHW taps in turn and ensure that water flows freely and that the mode knob is either in summer or winter position. The boiler will display

**“Hot Water” - “Temperature XX°C” - “High Efficiency”**

where the temperature shown is the current Domestic Hot Water temperature.

When the burner is lit the light above the display will be on.

2. Close all taps except the furthest one from the boiler and check that the boiler is firing at maximum rate.

This is factory set to give a DHW temperature rise of approximately 35°C at the flow rate stated on page 6 under “operation”.

3. Reduce the DHW draw-off rate to about 3 l/min (0.7gpm) and check that the boiler modulates to deliver DHW at approximately 64°C (with the DHW temperature control knob set to maximum).
4. Close the DHW tap and check that the main burner extinguishes. The pump should overrun for 60 seconds during which the boiler will display **“Pump overrun”**. The fan will then continue to run for a further 3 minutes during which the boiler will display **“Fan Post Purge”** after which the boiler will display one of the following **“Standby mode” - “Summer mode” - “Winter Mode”** depending on the position of the mode knob.

**Note.** On systems in excess of 2 bar inlet pressure a water pressure governor may be required to prevent water noise.

### CH & DHW MODE

1. Ensure the CH controls are calling for heat and that the boiler mode knob is in the winter position and the CH flow temperature control knob is in the maximum position. The Boiler will display

**“Central Heating” - “Radiator Temp XXC”**

where the temperature shown is the current flow temperature.

When the burner is lit the light above the display will be on.

2. Fully open the DHW tap and check that hot water is delivered. The boiler will display **“Hot water” - “Temperature XX°C” - “High Efficiency”**
3. Gas Rate  
Check the boiler gas rate when the boiler is at full DHW output. Check at the gas meter, with no other appliance in use. Refer to Tables 2 and 3 for gas rates.
4. Close the DHW tap. The burner should remain on and the boiler will display **“Central heating” - “Radiator temp XXC”**.
5. Set the central heating external controls to off. The burner will go off and the fan and pump continue to run for 4 minutes. The boiler will display **“Pump overrun”** after which the boiler will display one of the following: **“Standby mode” - “Summer mode” - “Winter mode”** depending on the position of the mode knob.
6. Check the correct operation of the timer (if fitted) and all other system controls. Operate each control separately and check that the main burner responds.

*Note. The temperature displayed “XX°C” is that measured at that moment, not the set temperature.*

### WATER CIRCULATION SYSTEM

1. With the system COLD, check that the initial pressure is correct to the system design requirements.  
For pre-pressurised systems, this should be 1.0 bar.
2. With the system HOT, examine all water connections for soundness. The system pressure will increase with temperature rise but should not exceed 2.5 bar.
3. With the system still hot, turn off the gas, water and electricity supplies to the boiler and drain down to complete the flushing process.

**Note:** A flushing solution should be used during the flushing procedure. Flushing solutions: Fernox Superfloc, Sentinel X300 (new systems) or X400 (existing systems). Refer to Frame 5.

4. Refill and vent the system, add inhibitor (see Frame 5), clear all air locks and again check for water soundness.
5. Reset the system initial pressure to the design requirement.

6. Balance the system. Refer to Frame 4.
7. Check the condensate drain for leaks and check that it is discharging correctly.
8. Finally, set the controls to the User's requirements.

#### Notes.

1. If the pump has not operated in the last 24 hours it will run briefly to prevent seizure
2. If the diverter valve has not operated in the last 24 hours it will be operated briefly to prevent seizure. These two operations will not occur at the same time.

### WATER TEMPERATURES

Temperatures can be selected using the CH and DHW thermostats.

Knob Setting	CH Flow Temp °C (°F)	DHW Outlet Temp °C (°F)
Max	80 (176)	64 (147)
Min	30 (86)	40 (104)

## 42 HANDING OVER

**After completing the installation and commissioning of the system the installer should hand over to the householder by the following actions:**

1. Make the householder aware that the user instructions are located in the pocket in the drop down door and explain his/her responsibilities under the relevant national regulations.
2. Explain and demonstrate the lighting and shutting down procedures.
3. The operation of the boiler and the use and adjustment of all system controls should be fully explained to the householder, to ensure the greatest possible fuel economy consistent with the household requirements of both heating and hot water consumption.

Advise the User of the precautions necessary to prevent damage to the system and to the building, in the event of the system remaining inoperative during frosty conditions.

4. Explain the function and the use of the boiler heating and domestic hot water controls.

Explain that due to system variations and seasonal temperature fluctuations DHW flow rates/temperature rise will vary, requiring adjustment at the draw off tap. It is therefore necessary to draw the users attention to the section in the Users Instructions titled "Control of Water Temperature" and the following statement:

**"Additionally, the temperature can be controlled by the user via the draw-off tap: the lower the rate the higher the temperature, and vice versa".**

5. Explain the function of the boiler fault mode.  
Emphasise that if a fault is indicated, the boiler should be turned off and a Gas Safe Registered Engineer consulted. In IE contact a Registered Gas Installer (RGII).
6. Explain and demonstrate the function of time and temperature controls, radiator valves etc., for the economic use of the system.

7. If a timer is fitted draw attention to the timer Users Instructions and hand them to the householder.

8. Loss of system water pressure

Explain that the dial underneath the boiler indicates the central heating system pressure and that if the normal COLD pressure of the system is seen to decrease over a period of time then a water leak is indicated. Explain the re-pressurising procedure and if unable to re-pressurise or if the pressure continues to drop a registered local heating installer should be consulted.

9. Explain boiler reset procedure (refer to Frame 41B).

10. After installation and commissioning please complete the



Commissioning Checklist before

handover to the customer. For IE, it is necessary to complete a "Declaration of Conformity" to indicate compliance to I.S. 813:2002.

### IMPORTANT

11. A comprehensive service should be carried out ANNUALLY.  
Stress the importance of regular servicing by a Gas Safe Registered Engineer. In IE servicing work must be carried out by a Registered Gas Installer (RGII).
12. Inform the householder of the guarantee form and the requirement to register it to receive the full benefit of the warranty.

## 43 SERVICING SCHEDULE

For the very latest copy of literature for specification & maintenance practices, visit our website [www.keston.co.uk](http://www.keston.co.uk), where you will be able to download the relevant information.

**WARNING.** Always turn OFF the gas supply at the gas service cock, and switch OFF and disconnect the electricity supply to the appliance before servicing.

**Combustion testing must be carried out by a competent person using a combustion analyser conforming to BS7927.**

To ensure the continued safe and efficient operation of the appliance it is recommended that it is checked at regular intervals and serviced as necessary. The frequency of servicing will depend upon the installation condition and usage but should be carried out at least annually.

It is the law that any service work must be carried out by a Gas Safe Registered Engineer. In IE service work must be carried out by a Registered Gas Installer (RGI).

### INSPECTION

1. Light the boiler and carry out a pre-service check, noting any operational faults.
2. Check the flue terminal (and terminal guard if fitted) is undamaged and clear of any obstruction.
3. Check all water and gas joints for signs of leakage. Remake any suspect joints ensuring a gas tightness check is carried out if applicable and the water system is correctly refilled, vented and re-pressurised.

### CLEANING PROCEDURE

**Note.** In order to carry out either servicing or replacement of components the boiler front panel must be removed. Refer to Frame 44.

1. Clean the main burner. Refer to frame 46.
2. Clean the heat exchanger & condensate trap/siphon. Refer to Frames 47 & 48.
3. Check the main injector for blockage or damage. Refer to Frame 45.
4. Check that the flue terminal is unobstructed and that the flue system is sealed correctly.

ALSO IF THE DHW FLOW RATE IS IN QUESTION :-

5. Check the DHW filter for blockage. Refer to Frame 74.

The cleaning procedures are covered more fully in Frames 45-50 and MUST be carried out in sequence.

### IMPORTANT.

6. After completing the servicing or exchange of components always test for gas tightness.
7. When work is complete the front panel MUST be correctly refitted, ensuring that a good seal is made.

**Do NOT OPERATE the boiler if the front panel is not fitted.**

8. If, for any reason, the condensate trap/siphon has been removed ensure the trap is refilled with water before reassembling.
9. Check the gas consumption.
10. Check combustion by connecting the flue gas analyser to the flue gas sampling point as shown in the diagram and measure CO & CO<sub>2</sub>.

If the CO/CO<sub>2</sub> ratio is greater than 0.004 AND the integrity of the complete flue system and combustion circuit seals have been verified and the inlet gas pressure (and gas rate) have been verified, then contact Keston.

11. Complete the service section in the Benchmark Commissioning Checklist.

### GENERAL

**Please Note:** During routine servicing, and after any maintenance or change of part of the combustion circuit, the following must be checked:

- The integrity of the flue system and the flue seals,
- The integrity of the boiler combustion circuit and the relevant seals
- The operational (working) gas inlet pressure at maximum rate.
- The gas rate
- The combustion performance.

### COMPETENCE TO CARRY OUT THE CHECK OF COMBUSTION PERFORMANCE

**Please Note:** BS 6798:2009 Specification for installation and maintenance of gas-fired boilers of rated input not exceeding 70kW net advises that:

- The person carrying out a combustion measurement should have been assessed as competent in the use of a flue gas analyser and the interpretation of the results.
- The flue gas analyser used should be one meeting the requirements of BS7927 or BS-EN50379-3 and be calibrated in accordance with the analyser manufacturers requirements, and
- Competence can be demonstrated by satisfactory completion of the CPA1 ACS assessment, which covers the use of electronic portable combustion gas analysers in accordance with BS7967, Parts 1 to 4.

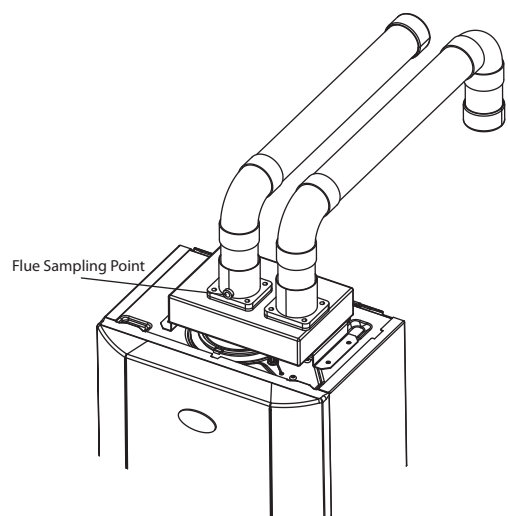

## SERVICING

### 44 BOILER FRONT PANEL REMOVAL / REPLACEMENT

#### REMOVAL

1. Loosen the two screws retaining the front panel.
2. Pull the two spring clips down to disengage and pull panel forward and upward and remove.

#### REPLACEMENT

3. Hook the panel onto the top retaining clips.
4. Push the panel until the 2 bottom spring clips engage ensuring the 4 control knobs line up with the holes in the front panel.
5. Re-tighten the two retaining screws.

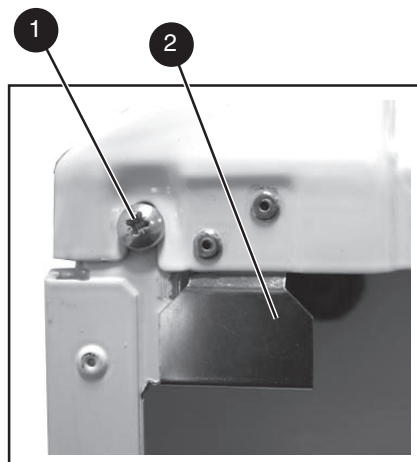

view from bottom of boiler

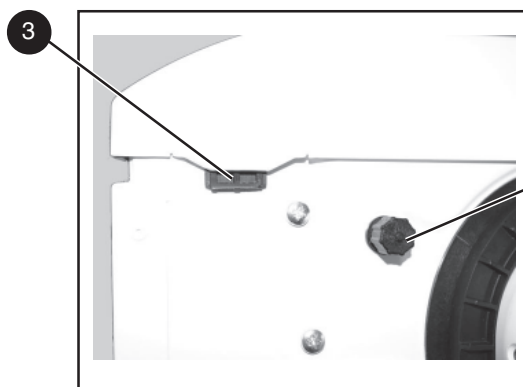

view from top of boiler

### 45 FAN AND VENTURI ASSEMBLY REMOVAL AND CLEANING

1. Disconnect the electrical leads from the fan.
2. Undo the gas pipe union connection to the injector housing.
3. Remove the extended nut on the fan mounting bracket.
4. Lift off fan and venturi assembly.
5. Inspect the injector for blockage or damage.
6. Inspect fan outlet sealing gasket and replace if necessary.

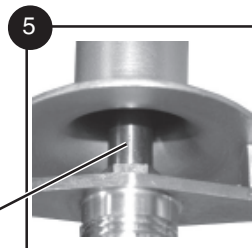
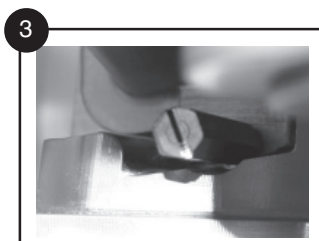

Injector

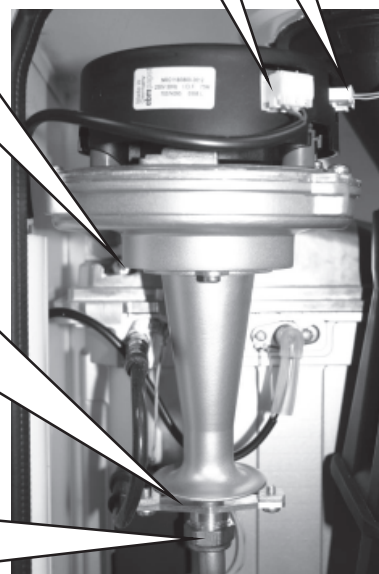
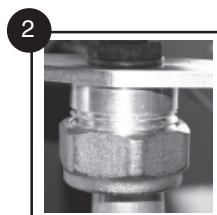

## 46 BURNER REMOVAL AND CLEANING

1. Ensure the sump is fully drained
2. Undo the two screws and remove the sump cover retaining the lower flue manifold.
3. Lift the manifold to clear the bottom sealing gasket and remove manifold.
4. Remove the 2 burner front fixing screws and loosen the 2 rear extended nuts by at least ten turns.
5. Lift off the burner from the combustion chamber. To facilitate the removal angle the burner as shown.

### IMPORTANT

The burner head is a ceramic plaque construction. Care must be taken to ensure that **the burner is not placed down upon its face** as this may cause damage to the ceramic.

6. Brush off any deposits that may be on the ceramic with a SOFT brush.
7. Inspect the sealing gasket around the burner for any signs of damage. Replace as necessary.

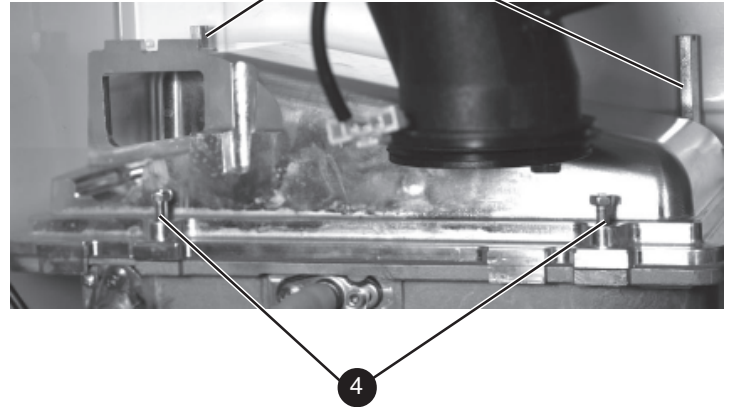
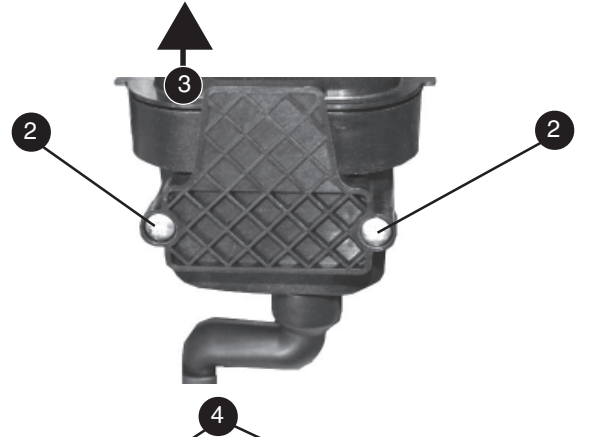

## 47 CLEANING THE CONDENSATE TRAP/SIPHON

1. Remove the cleaning plug taking care with any residual condensate.
2. Pull off the rubber pipe noting the position and flush out any deposits with clean water.
3. Replace the cleaning plug and refill the siphon with water.
4. Replace the rubber pipe connector with the twin wall seal fitted to the condensate siphon.

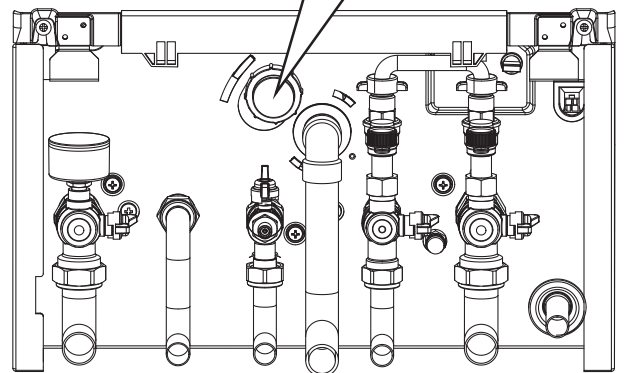
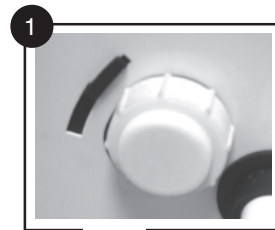
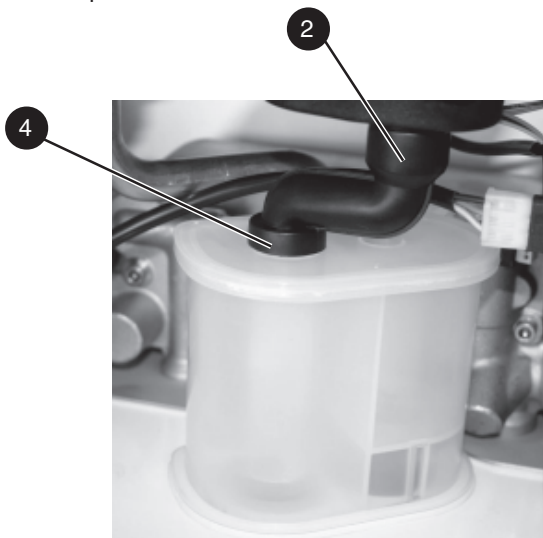

3G9690

## 48 CLEANING THE HEAT EXCHANGER

**Note:** Ensure the condensate trap/siphon is fully drained before cleaning. Refer to Frame 61.

1. Remove ignition and flame detection electrodes. Refer to Frames 56 & 57.
2. It is advisable to replace the sump cover prior to the water flush process.
3. Thoroughly flush the heat exchanger by pouring water into the top of the combustion chamber ensuring the full top area is covered.
4. Remove the sump cover and clean loose deposits from the sump.
5. Inspect the ignition and detection electrodes. Ensure that they are clean and in good condition - replace if necessary.
6. Re-fit the ignition and flame detection electrodes, ensuring that both earth tabs are fitted to ignition electrode.
7. Check that the ignition and detection gaps are correct. Refer to Frames 56 & 57.

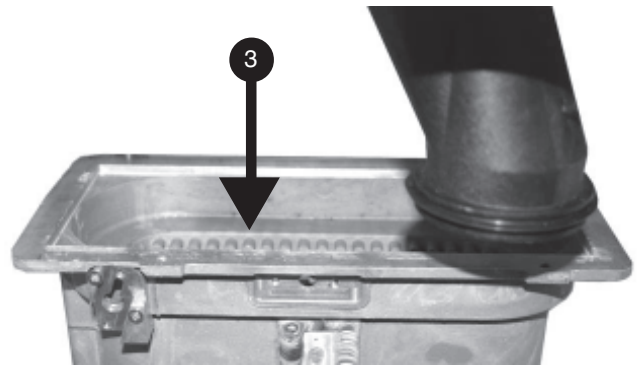
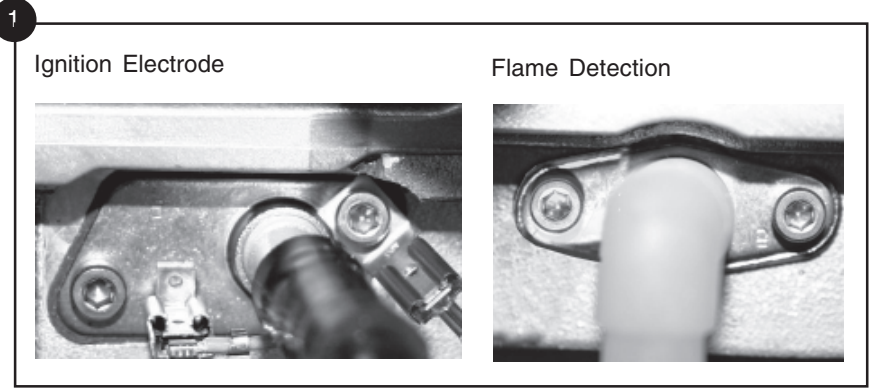

## 49 REASSEMBLY

**Reassemble the boiler in the following order:**

1. Ensure that the condensate trap/siphon is full of water.
  2. Refit the burner ensuring the sealing gasket is correctly positioned and free from damage (tighten the 4 fixing screws in the sequence shown below).
  3. Refit the fan / venturi assembly ensuring the retaining tabs are correctly positioned and the sealing gasket is correctly positioned and free from damage.
  4. Reconnect the fan electrical leads.
  5. Remove the sump cover and refit the lower flue manifold as shown.
  6. Refit the sump cover.
  7. Refit the boiler front panel.
- IMPORTANT.** Ensure that the boiler front panel is correctly fitted and that a good seal is made.
8. Swing the control box back into its working position and secure.
  9. Turn on the gas supply at the gas service cock.
  10. Reconnect the electrical supply.

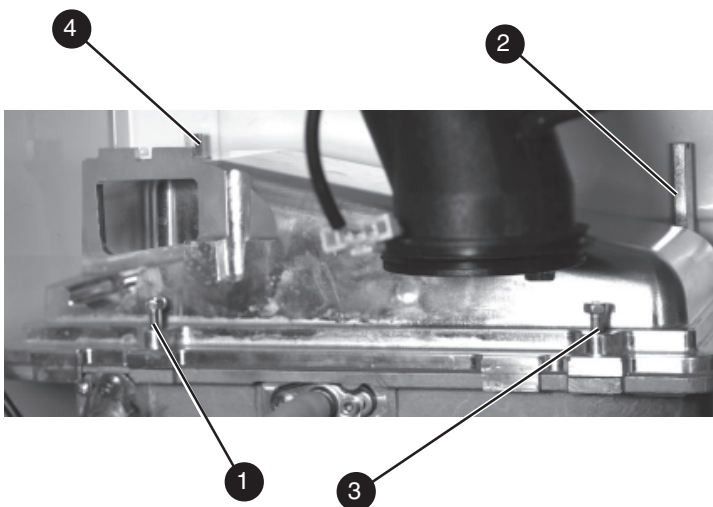

## 50 REPLACEMENT OF COMPONENTS

### GENERAL

#### When replacing ANY component

1. Isolate the electricity supply.
2. Turn off the gas supply.
3. Remove the boiler front panel. Refer to Frame 44.
4. Release the retaining clip and swing the control box down into its servicing position.

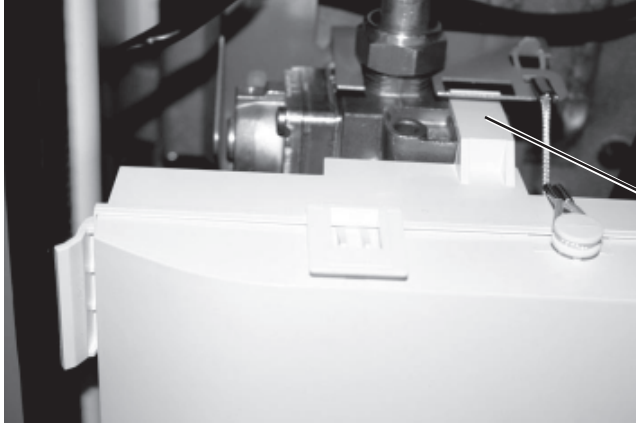

After replacing ANY component check operation of the boiler, including gas tightness, gas rate and combustion test.

### IMPORTANT.

When work is complete, the front panel must be correctly refitted - ensuring that a good seal is made.

### Notes.

1. In order to assist fault finding, the control panel has an LED diagnostic display. The key to boiler fault conditions is shown in Frame 80.
2. In order to replace components in Frames 66-78 it is necessary to drain the boiler. Refer to Frame 65.

**THE BOILER MUST NOT BE OPERATED WITHOUT THE FRONT PANEL FITTED**

## 51 FAN REPLACEMENT

1. Refer to Frame 50.
2. Disconnect the electrical leads from the fan.
3. Undo the gas pipe union connection to the injector housing.
4. Remove the extended nut retaining the fan mounting bracket.
5. Lift and remove the fan and venturi assembly.
6. Remove the screw and twist venturi anti-clockwise to remove venturi assembly, *noting the orientation of the venturi in relation to the fan body.*
7. Transfer the venturi assembly to the new fan, replacing the 'o' ring if evidence of damage or deterioration is visible.
8. Fit the new fan / venturi assembly ensuring the retaining tabs are correctly positioned and the fan outlet sealing gasket is correctly positioned and free from damage. Refit the extended nut.
9. Reassemble the boiler in reverse order, taking care not to overtighten the screw on the fan mounting bracket.
10. Check the operation of the boiler. Refer to Frames 40 & 41.

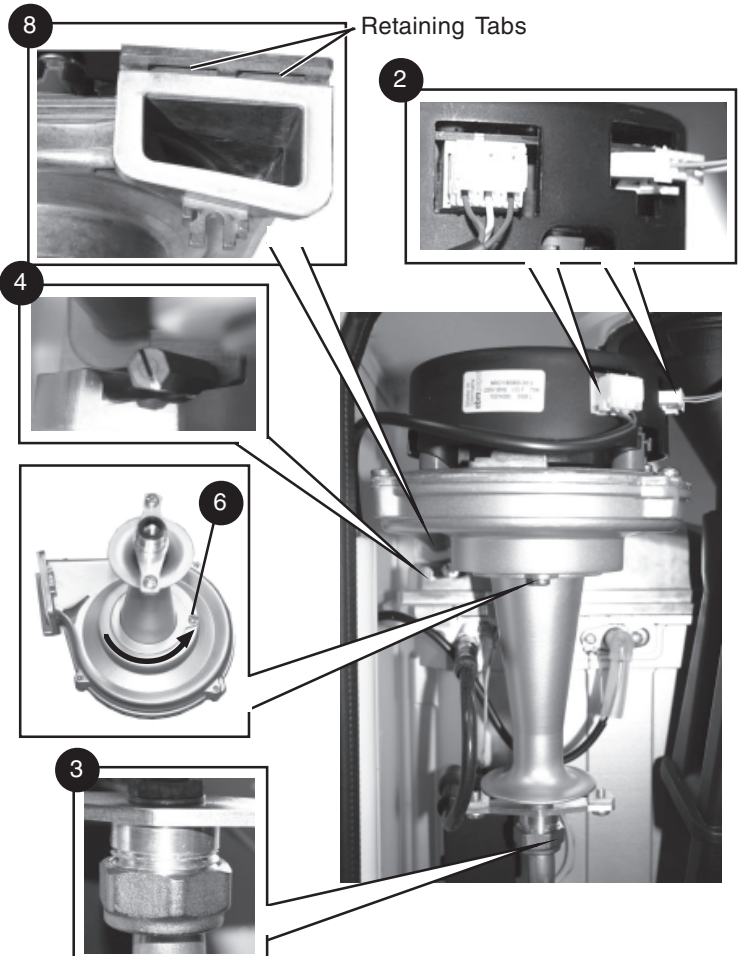



## 52 BURNER INJECTOR REPLACEMENT

1. Refer to Frame 50.
2. Disconnect the electrical leads from the fan.
3. Undo the gas pipe union connection to the injector housing.
4. Loosen the screw retaining the fan mounting bracket.
5. Lift and remove the fan and venturi assembly.
6. Remove the 2 injector housing screws.
7. Withdraw the injector housing.
8. Fit the new injector housing complete with injector.
9. Reassemble in reverse order, ensuring that the new gas seal supplied is located correctly in the injector housing.
10. Check operation of the boiler. Refer to Frames 40 & 41.

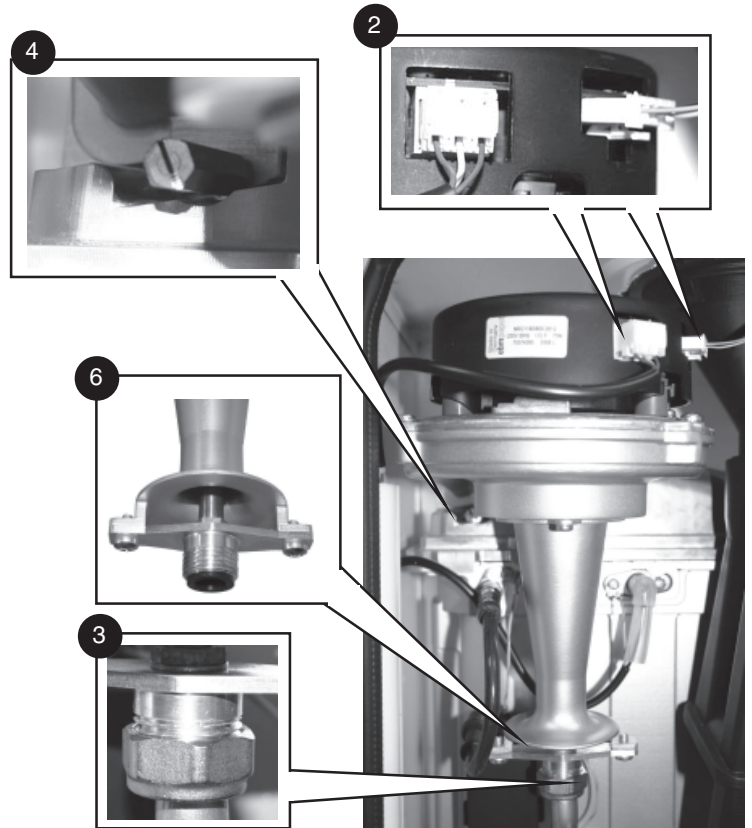

## 53 BURNER REPLACEMENT

1. See Frame 46.
2. Refer to Frame 50.
3. Disconnect 2 flag terminals from the flue thermostat.
4. Undo the two screws and remove the sump cover.
5. Lift the manifold to clear the bottom sealing gasket and remove manifold.
6. Remove the 2 front fixing screws and loosen the 2 rear extended nuts.
7. Lift off the burner from the combustion chamber. To facilitate the removal angle the burner as shown.
8. Fit the new burner, replacing any damaged or deteriorating sealing gasket.
9. Reassemble in reverse order. Refer to Frame 49.
10. Check the operation of the boiler. Refer to Frames 40 & 41.

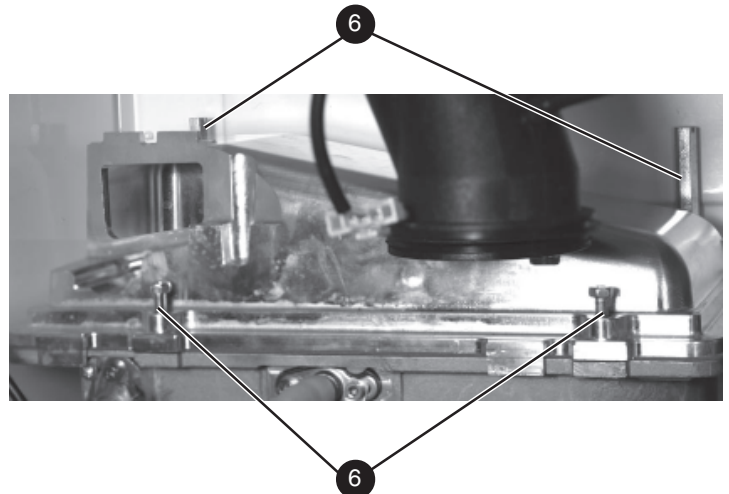
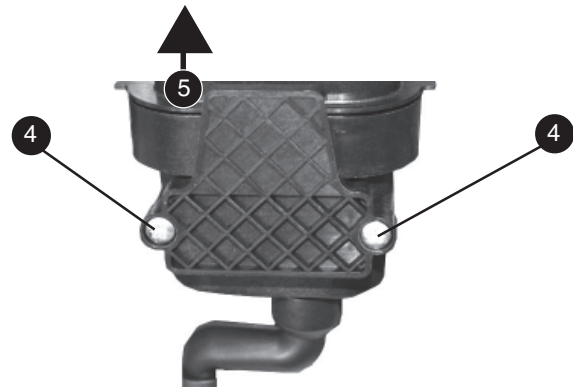

## 54 CONTROL THERMISTOR & RETURN THERMISTOR RENEWAL

1. Refer to Frame 50.
2. Unclip the control thermistor from the flow pipe and withdraw it from the boiler.
3. Unclip the return thermistor from the return pipe and withdraw it from the boiler.
4. Disconnect the electrical leads from the thermistors.
5. Reconnect the electrical leads to the new thermistors and reassemble in reverse order, ensuring that the thermistors are securely fitted to the pipes on the thermistor locator tabs as shown.
6. Check the operation of the boiler. Refer to Frames 40 & 41.

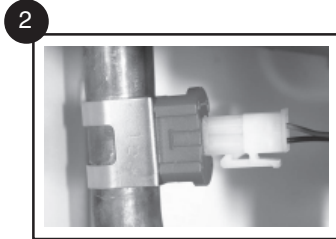
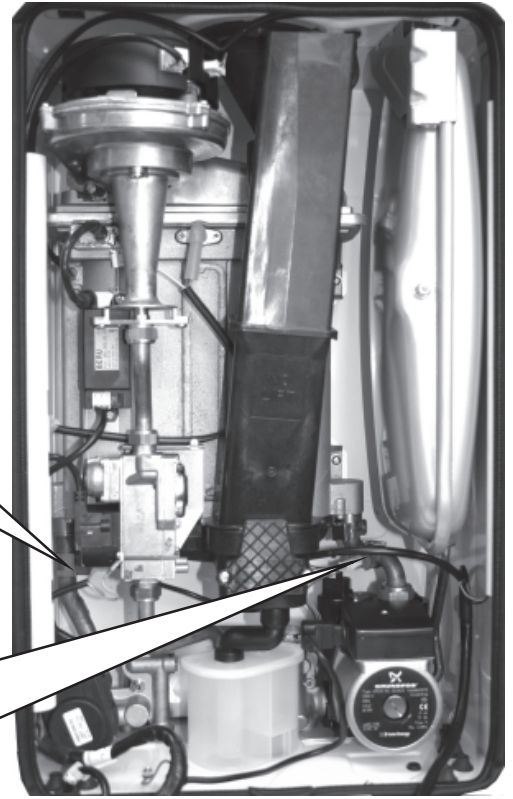

## 55 FLUE THERMOSTAT REPLACEMENT

1. Refer to Frame 50.
2. Undo the two screws and remove the sump cover plate.
3. Disconnect the two flag terminals from the flue thermostat.
4. Lift the manifold to clear the bottom sealing gasket and remove manifold.
5. Unscrew the two M3.5 screws that connect the thermostat to the manifold.
6. Replace thermostat with new part and then refit the two screws, remembering to fit rubber gasket and sealing clamp.

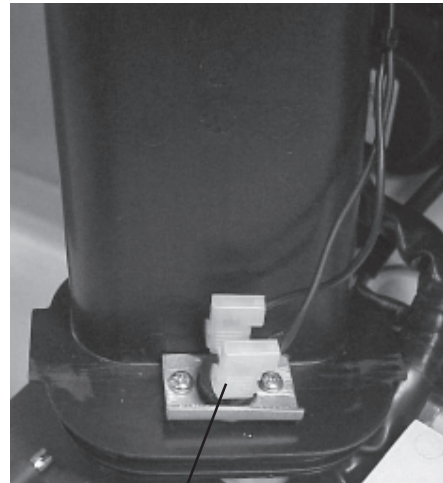

Flue Thermostat

**56 IGNITION ELECTRODE REPLACEMENT**

1. Refer to Frame 50.
2. Remove the burner. Refer to Frame 53.
3. Unplug the ignition lead from the electrode.
4. Remove the earth lead from the ignition electrode.
5. Remove the 2 screws holding the ignition electrode to the combustion chamber.
6. Remove the electrode.
7. Fit the new ignition electrode, using the new gasket supplied. Check dimensions as shown.
8. Reassemble in reverse order.
9. Check the operation of the boiler. Refer to Frames 40 & 41.

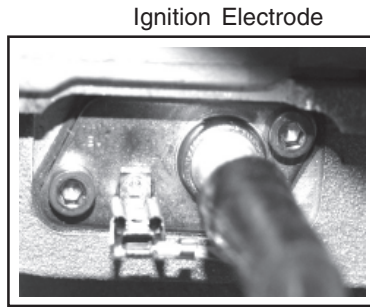

Ignition Electrode

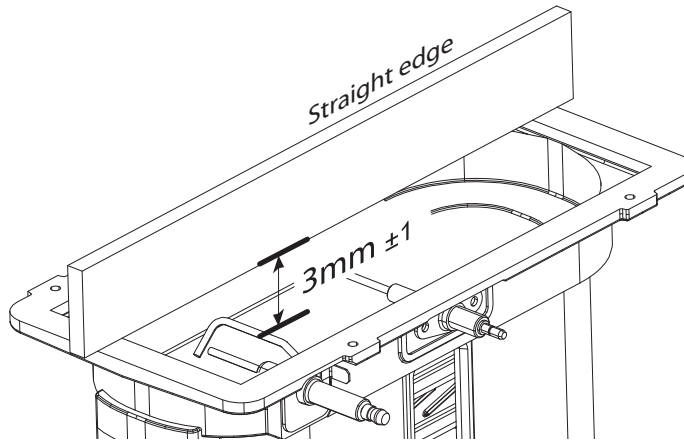
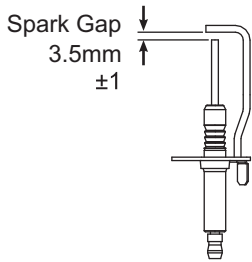
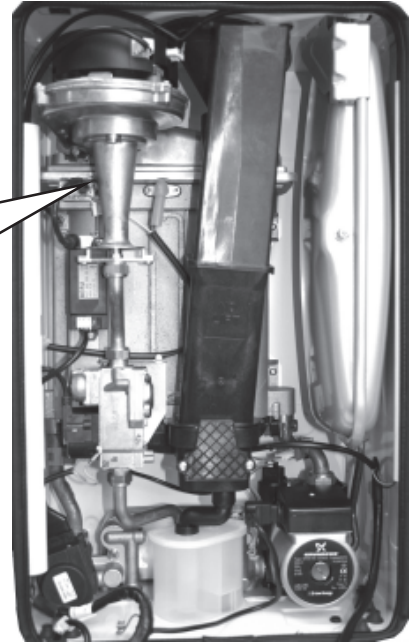

**57 FLAME DETECTION ELECTRODE REPLACEMENT**

1. Refer to Frame 50.
2. Remove the burner. Refer to Frame 53.
3. Unplug the flame detection lead from the electrode.
4. Remove the 2 screws retaining the detection electrode.
5. Remove the electrode.
6. Fit the new flame detection electrode, using the new gasket supplied.
7. Reassemble in reverse order.
8. Check the operation of the boiler. Refer to Frames 40 & 41.

Flame Detection Electrode

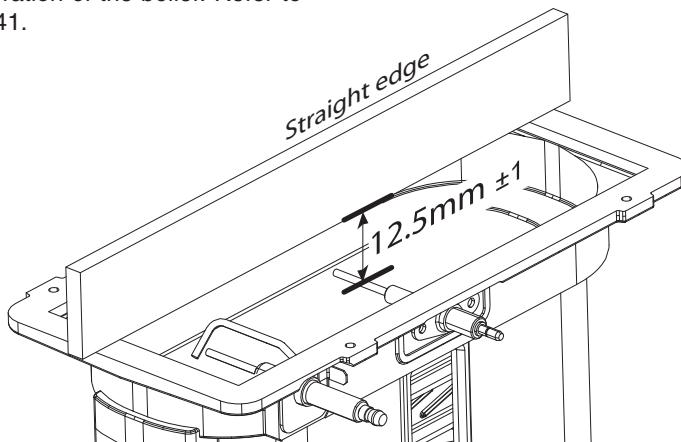
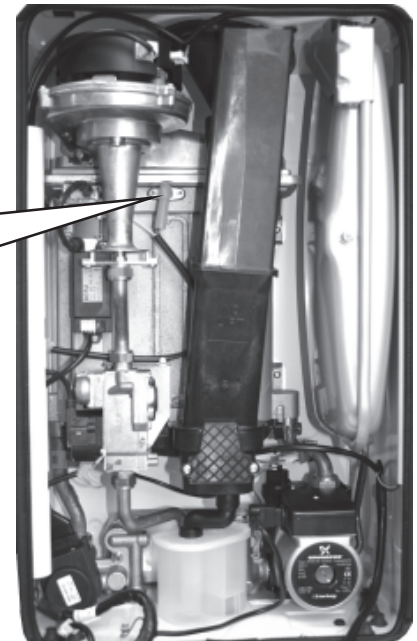
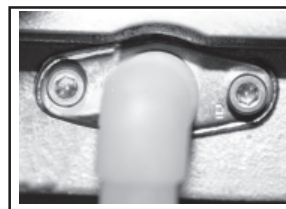

## 58 SPARK GENERATOR REPLACEMENT

1. Refer to Frame 50.
2. Disconnect the leads from the spark generator.
3. Remove the M5 screws securing the spark generator to the boiler chassis.
4. Fit the new spark generator and re-assemble in reverse order ensuring the two earth leads are correctly replaced.
5. Check operation of the boiler. Refer to Frames 40 & 41.

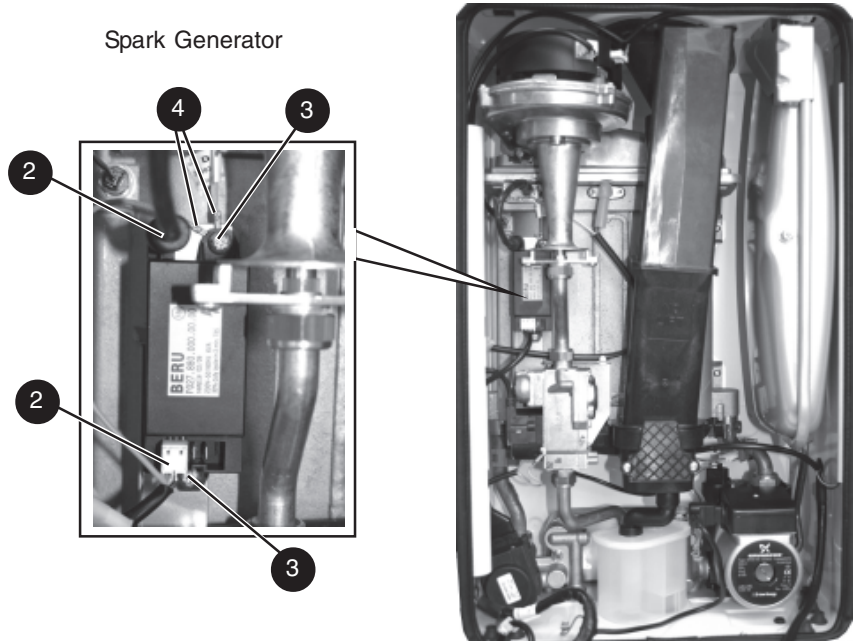

## 59 GAS CONTROL VALVE REPLACEMENT

1. Refer to Frame 50.
2. Unplug the electrical plug connection from the gas control valve and disconnect the earth wire.
3. Undo the union nut on the outlet of the gas control valve.
4. Undo the gas inlet pipe union at the inlet to the gas control valve.
5. Loosen the back nut retaining the valve to the bracket and withdraw the valve forwards.
6. Fit the new gas control valve ensuring the two sealing washers are in place and reconnect gas and electrical connections.
7. Check operation of the boiler. Refer to Frames 40 & 41.

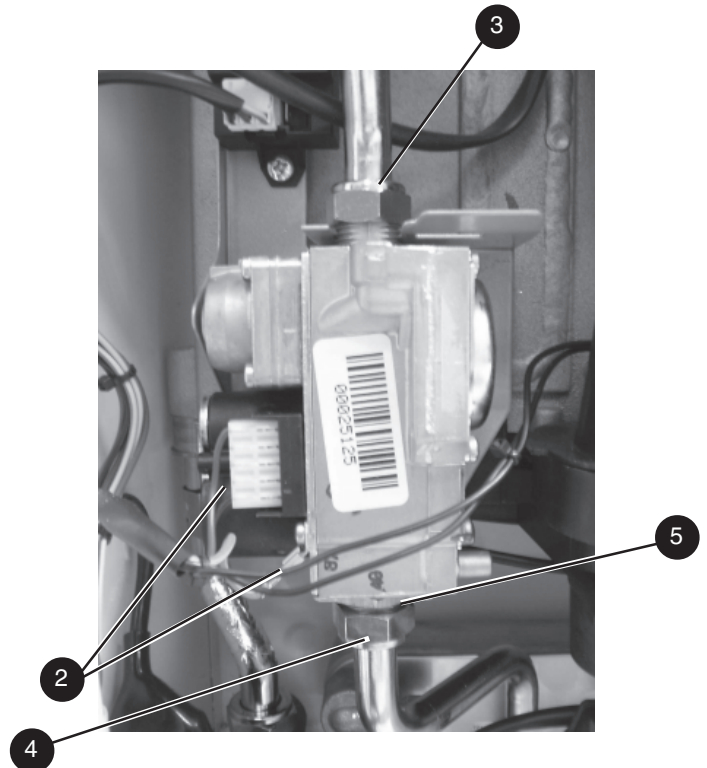

## 60 DIVERTER VALVE ACTUATOR REPLACEMENT

1. Refer to Frame 50.
2. Remove the electrical plug.
3. Using a suitable tool pull out the retaining clip and lift the diverter head from the brass body.
4. Fit new actuator head and reassemble in reverse order.
6. Check operation of the boiler. Refer to Frames 40 & 41.

Diverter Valve Actuator

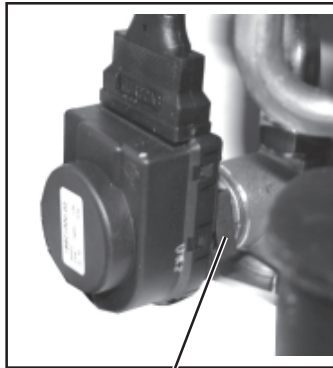

Retaining Clip

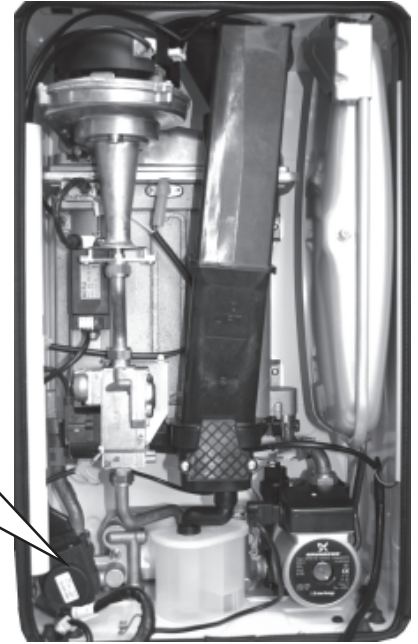

## 61 CONDENSATE TRAP/SIPHON REPLACEMENT

1. Refer to Frame 50.

**Note:** Ensure condensate trap is fully drained before removal.

2. Pull off the rubber pipe at the sump drain.
3. Disconnect the condensate drain pipe.
4. Remove the cleaning plug
5. Turn the siphon clockwise to disengage and lift to remove.
6. Reassemble in reverse order.
7. When reassembling ensure the trap is full of water.
8. Check operation of the boiler. Refer to Frames 40 & 41.

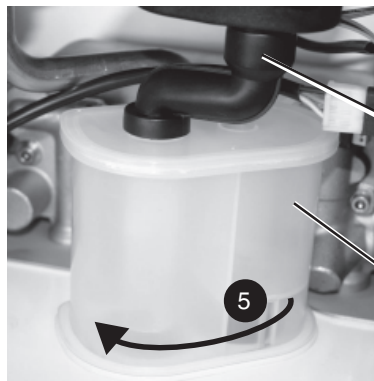

Siphon

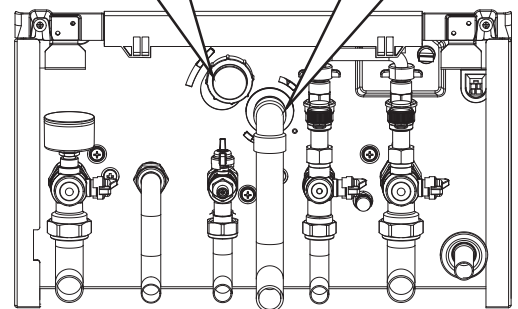
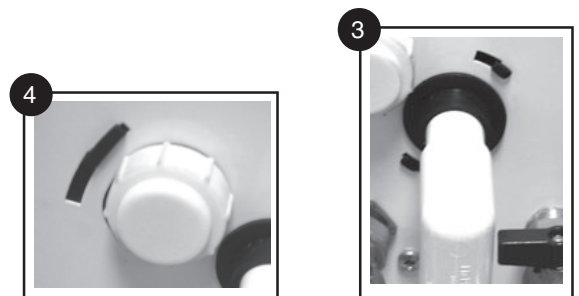

3G9690

## 62 MAIN PCB REPLACEMENT

**Note.** Fit the earth strap provided with the PCB to your wrist and secure to a suitable earth on the boiler chassis.

1. Refer to Frame 50.
2. Note the control knob positions.
3. Remove the 2 screws retaining the control box cover.
4. Carefully lift the 4 retaining clips and remove control box cover.
5. Unplug all lead connections to the PCB including the ribbon cable (to facilitate ribbon cable removal, ease side clips apart and pull upwards), also where applicable, push the small plastic clip with an electrical screwdriver to facilitate plug removal.
6. Spring out the two side retaining clips and pull the PCB upwards to clear the 4 corner retaining posts.
7. Take the new Primary PCB and attach the appropriate Boiler Chip Card (BCC).

**Note.** Ensure the correct orientation of BCC by placing "TOP" side up as shown.

8. Re-connect all plug connections.
9. Reassemble in reverse order.
10. Turn power back on to the boiler, after a few moments the display will start alternating between "c" and "0". Turn the reset knob fully clockwise and when the display shows " - " turn the knob fully anti-clockwise IMMEDIATELY.  
Finally move the knob into the required position (Standby, Summer or Winter).
11. Check operation of the boiler. Refer to Frames 40 & 41.

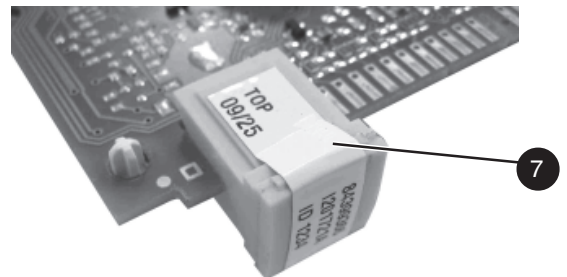
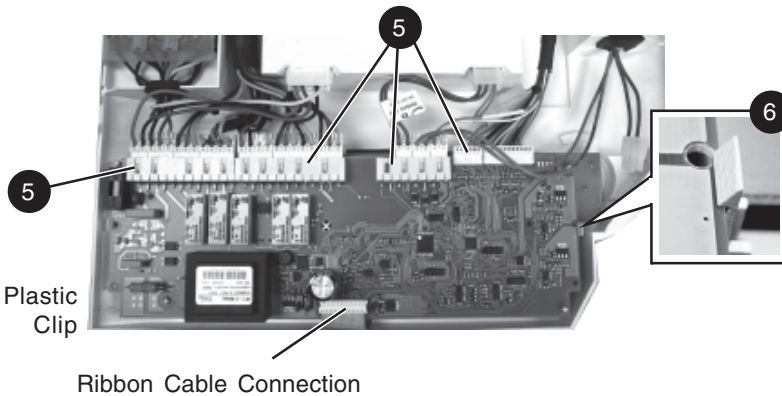
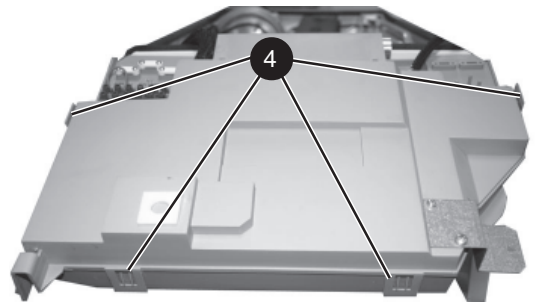
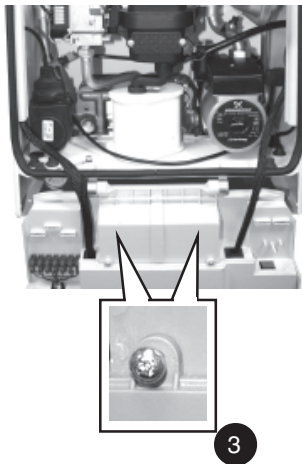

## 63 USER CONTROL PCB REPLACEMENT

**Note.** Fit the earth strap provided with the PCB to your wrist and a suitable earth on the boiler chassis.

1. Refer to Frame 50.
2. Remove the main PCB, refer to Frame 62.
3. Unclip the PCB and lift to clear the mounting posts.
4. Fit the new PCB ensuring the 4 potentiometer spindles line up with the control knobs which must be in a vertical position.
5. Reassemble in reverse order.
6. Check operation of the boiler. Refer to Frames 40 & 41.

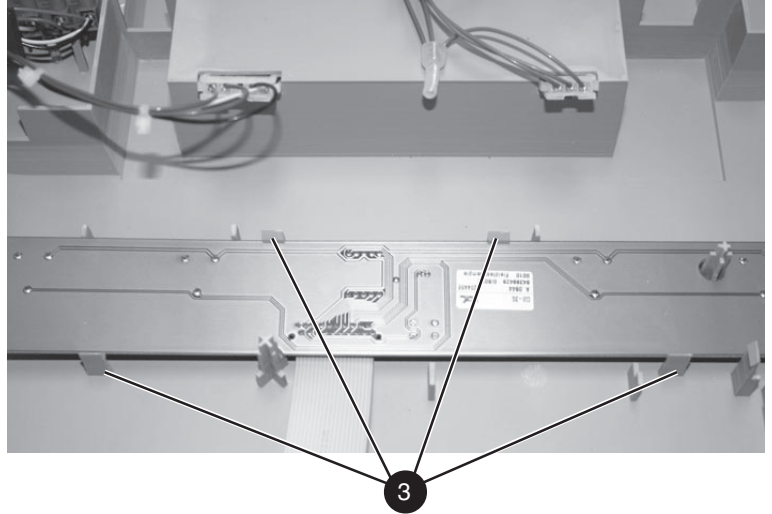

**4**

**PCB**

**Control Knobs (to be in vertical position)**

**Potentiometer spindle**

## 64 DHW FLOW TURBINE SENSOR REPLACEMENT

1. Refer to Frame 50.
2. Remove condensate trap/siphon. Refer to Frame 61.
3. Lift off the flow turbine sensor plastic retaining clip.
4. Unplug the electrical connection and transfer to new turbine sensor.
5. Reassemble in reverse order.
6. Check operation of the boiler. Refer to Frames 40 & 41.

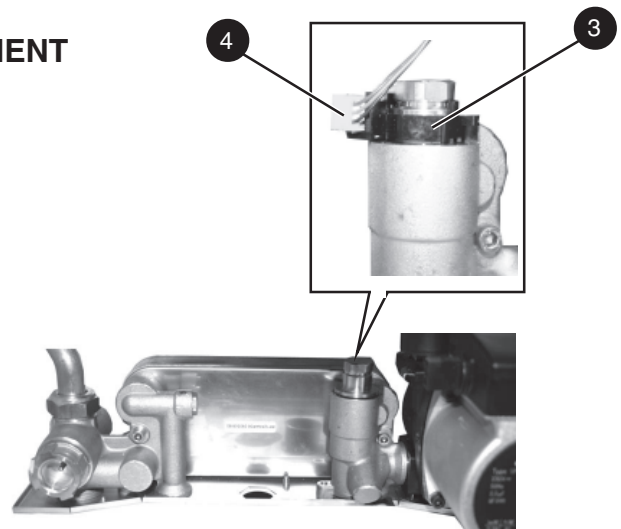

## 65 DRAINING THE BOILER

### CENTRAL HEATING CIRCUIT

1. Refer to Frame 50.
2. Close all the CH water isolating valves on the boiler inlet.
3. To drain the primary heat exchanger circuit: Open the drain valve and attach a length of hose to the CH drain point.
4. After replacing any component on the boiler, remove the hose, close the drain valve and open all system isolating valves (re-pressurise as appropriate by re-connecting the filling loop, refer to Frame 30) before proceeding to check operation of the boiler.
5. Disconnect filling loop. Refer to Frame 30.
6. Check operation of the boiler. Refer to Frames 40 & 41.

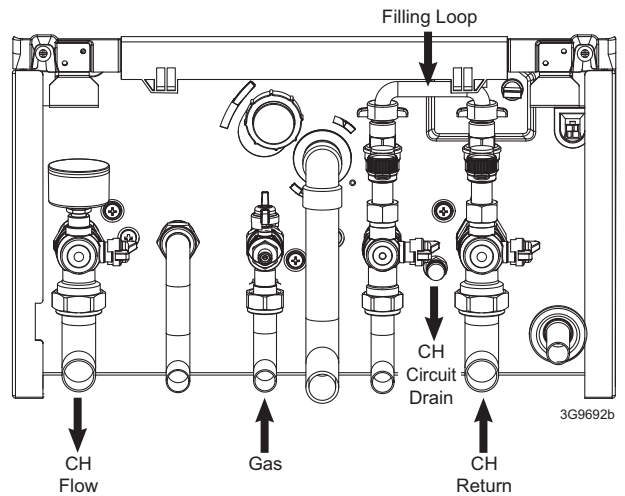

### DOMESTIC HOT WATER CIRCUIT

1. Refer to Frame 50.
2. Close all the DHW water isolating valves on the boiler inlet.
3. To drain the domestic hot water circuit: As there is no direct drain for the domestic hot water circuit, depending on the location of the boiler, opening the lowest hot water tap may drain this circuit. However it must be noted that some residual water will be experienced during replacement of components.
4. After replacing any component on the boiler, close tap, close the drain valve and open all system isolating valves (re-pressurise as appropriate by re-connecting the filling loop, refer to Frame 30) before proceeding to check operation of the boiler.
5. Disconnect filling loop. Refer to Frame 30.
6. Check operation of the boiler. Refer to Frames 40 & 41.

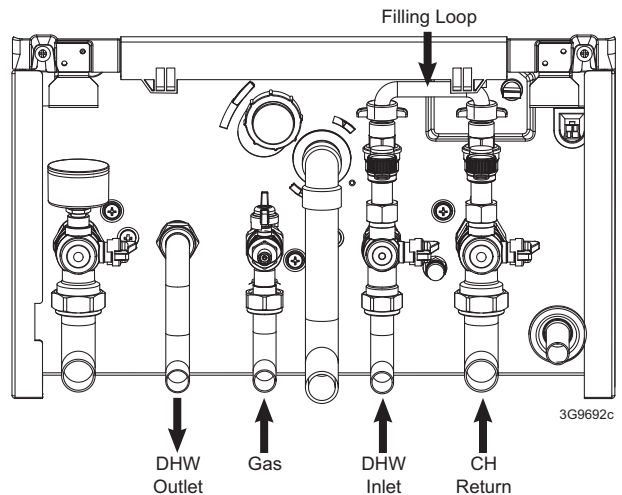

## 66 PRESSURE GAUGE RENEWAL

1. Refer to Frame 50.
2. Drain the heating system. Refer to Frame 65.
3. Unscrew the pressure gauge and discard.
4. Fit new pressure gauge, using suitable jointing compound.
5. Refill the boiler. Refer to Frame 30.
6. Check operation of the boiler. Refer to Frames 40 & 41.

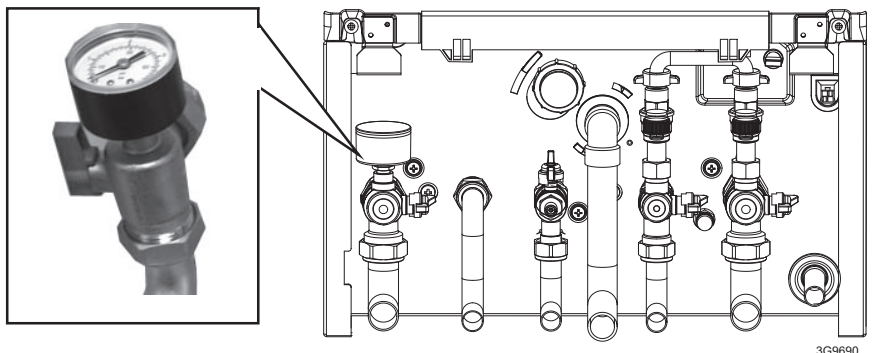



## 67 SAFETY RELIEF VALVE RENEWAL

1. Refer to Frame 50.
2. Drain the boiler. Refer to Frame 65.
3. Remove the condensate trap/siphon. Refer to Frame 61.
4. Remove expansion vessel. Refer to Frame 78.
5. Disconnect the electrical connection from the return thermistor.
6. Disconnect the 22mm pipe connection at the rear of the pump outlet.
7. Pull off the clip retaining the pipe to the heat exchanger swinging the pipe to clear the pump and remove pipe.
8. Undo the safety valve union connection.
9. Withdraw the clip securing the safety valve.
10. Lift safety valve from boiler.
11. Fit the new safety valve and reassemble in reverse order ensuring the new 'o' ring is fitted to the top of the return pipe.
12. Refill boiler. Refer to Frame 30. Check operation of boiler. Refer to Frames 40 & 41.

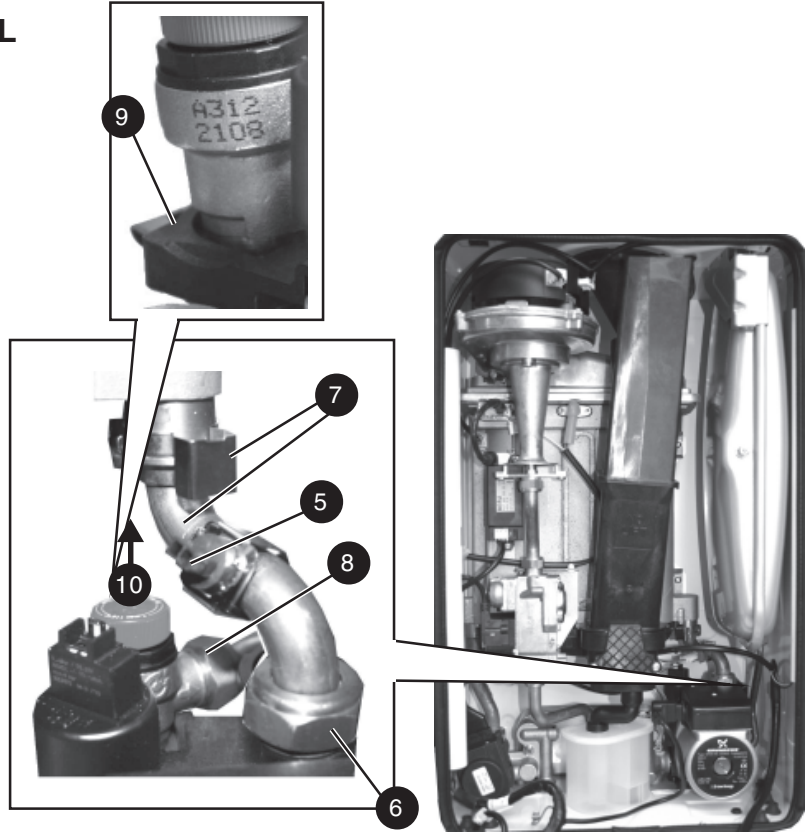

## 68 PUMP AUTOMATIC AIR VENT REPLACEMENT

1. Refer to Frame 50.
2. Drain the boiler. Refer to frame 65.
3. Remove the expansion vessel. Refer to Frame 78.
4. Firstly, increase access area by disconnecting the 22mm pipe connection at top of pump chamber and bottom of heat exchanger and remove pipe Refer to Frame 67 (no's 5,6 & 7).
5. The automatic air vent head is retained in the pump body with a bayonet connection. The air vent head and float assembly is removed by turning the head anti-clockwise (viewed from above) and pulling upwards.
6. Reassembly is the reverse of the above. Ensure the air vent head 'o' ring seal is in place when refitting and the new 'o' ring is fitted to the return pipe top connection.
7. Ensure the air vent cap is loose.
8. Refill the boiler. Refer to Frame 30. Check for leaks around the new air vent joint.
9. Check the operation of the boiler. Refer to Frames 40 & 41.

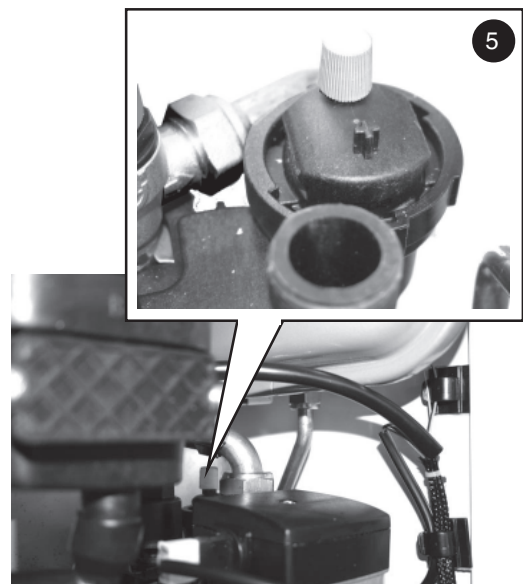

# SERVICING

## 69 DHW FLOW TURBINE CARTRIDGE REPLACEMENT

1. Refer to Frame 50.
2. Drain the boiler. Refer to Frame 65.
3. Remove condensate trap/siphon. Refer to Frame 61.
4. Remove the DHW flow turbine sensor. Refer to Frame 64.
5. Unscrew the top connection to access the internal part.
6. Fit the new turbine cartridge.
7. Refit the turbine flow sensor
8. Reassemble in reverse order.
9. Refill the boiler. Refer to Frame 30.
10. Check operation of the boiler. Refer to Frames 40 & 41.

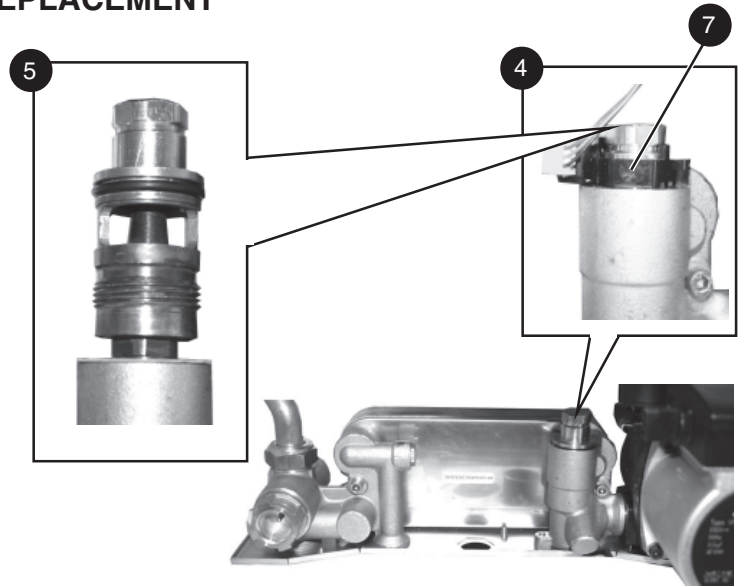

## 70 DIVERTER VALVE INTERNAL CARTRIDGE REPLACEMENT

### FRONT CARTRIDGE REPLACEMENT

1. Refer to Frame 50.
2. Drain the boiler. Refer to Frame 65.
3. Remove the diverter valve head. Refer to Frame 60.
4. Unscrew the top connection to access the internal cartridge.
5. Fit the new valve mechanism ensuring the correct fit of the pin.
6. Reassemble in reverse order.
7. Refill the boiler. Refer to Frame 30.
8. Check operation of the boiler. Refer to Frames 40 & 41.

### REAR CARTRIDGE REPLACEMENT

1. Refer to Frame 50.
2. Drain the boiler. Refer to Frame 65.
3. Remove the diverter valve head. Refer to Frame 60.
4. Remove the flow pipe. Refer to Frame 77 no. 12.
5. Disconnect the CH flow pipe and DHW outlet pipe union connections underneath the boiler. Refer to Frame 65.
6. Remove the plate heat exchanger LH fixing screw. Refer to Frame 71.
7. Remove the screw retaining the brass block to the bottom of the boiler casing and lift the brass block clear of the boiler.
8. Unscrew the rear cartridge connection.
9. Fit the new valve mechanism ensuring the correct fit of the pin.
10. Reassemble in reverse order.
11. Refill the boiler. Refer to Frame 30.
12. Check operation of the boiler. Refer to Frames 40 & 41.

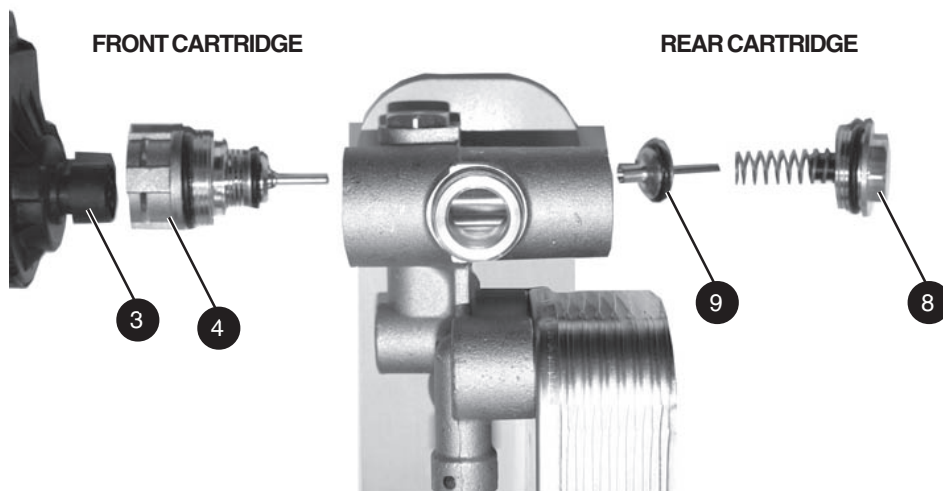

# SERVICING

## 71 DHW PLATE HEAT EXCHANGER REPLACEMENT

1. Refer to Frame 50.
2. Drain the boiler. Refer to Frame 65.
3. Remove condensate trap/siphon. Refer to Frame 61.
4. Remove the diverter valve actuator. Refer to Frame 60.
5. Remove the 2 allen screws securing the plate heat exchanger to the brass housings.
6. Manoeuvre the plate heat exchanger out of the top LH or centre of the controls area.
7. Fit the new plate heat exchanger, using the new o-rings supplied.
8. Reassemble in reverse order.
9. Refill the boiler. Refer to Frame 30.
10. Check operation of the boiler. Refer to Frames 40 & 41.

**Note.** The mounting pins are offset so the correct position can be defined from the location of the holes on the brass mounting.

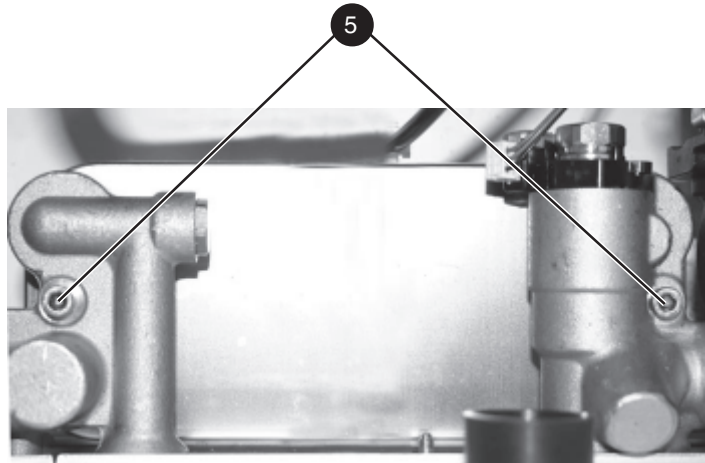

## 72 PUMP HEAD REPLACEMENT

1. Refer to Frame 50.
2. Drain the boiler. Refer to Frame 65.
3. Disconnect the electrical plug from the pump.
4. Remove the 4 Allen screws retaining the pump head.
5. Remove the pump head.
6. Fit the new pump head.
7. Reassemble in reverse order.
8. Refill the boiler. Refer to Frame 30.
9. Check operation of the boiler. Refer to Frames 40 & 41.

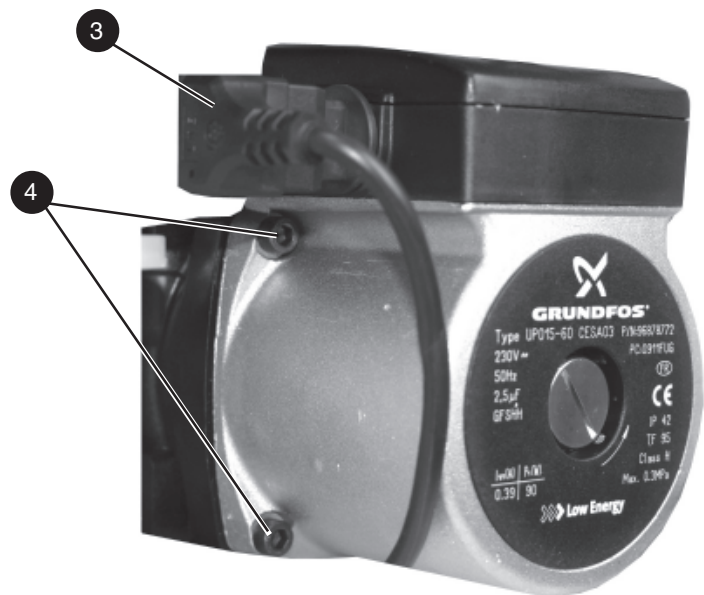

## 73 CH WATER PRESSURE SENSOR REPLACEMENT

1. Refer to Frame 50.
2. Drain the boiler. Refer to Frame 65.
3. Remove condensate trap/siphon. Refer to Frame 61.
4. Using a suitable tool pull out the retaining clip.
5. Pull the pressure sensor upwards to remove.
6. Unplug the electrical connection and transfer to the new pressure sensor.
7. Push the new pressure sensor onto the rear pump housing and fit retaining clip.
8. Reassemble in reverse order.
9. Refill the boiler. Refer to Frame 30.
10. Check Operation of the boiler. Refer to Frames 40 & 41.

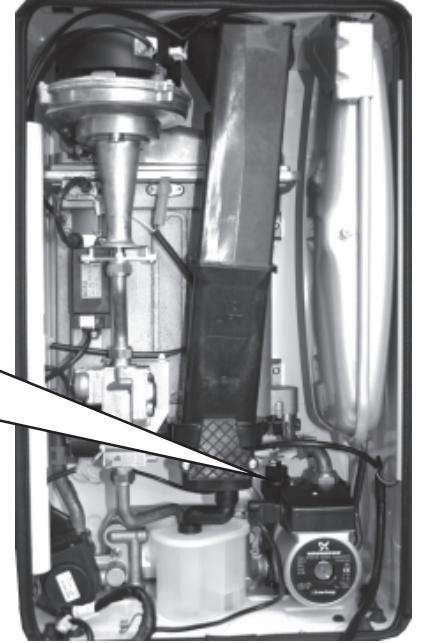
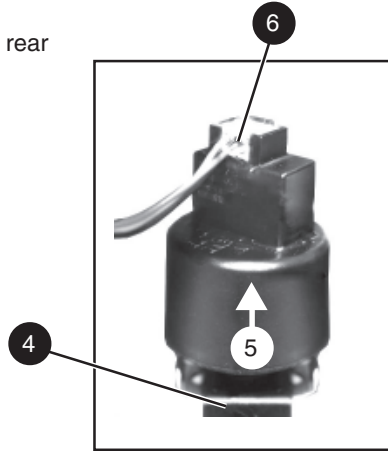

## 74 DHW FILTER CLEANING / REPLACEMENT

1. Refer to Frame 50.
2. Isolate the mains cold water supply to the boiler.
3. Drain the boiler DHW circuit. Refer to frame 65.
4. Remove the DHW flow turbine cartridge. Refer to Frame 69.
5. Unscrew the flow regulator housing.
6. Remove the filter.
7. Clean or replace filter as necessary.
8. Reassemble in reverse order.
9. Refill the boiler. Refer to Frame 30.
10. Check Operation of the boiler. Refer to Frames 40 & 41.

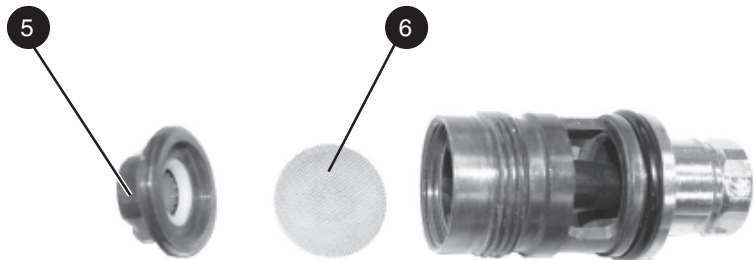

## 75 DHW FLOW REGULATOR CLEANING / REPLACEMENT

1. Refer to Frame 50.
2. Isolate the mains cold water supply to the boiler.
3. Drain the boiler DHW circuit. Refer to Frame 65.
4. Remove the DHW flow turbine cartridge. Refer to Frame 69.
5. Unscrew the flow regulator housing.
6. Inspect the flow regulator for any blockage and remove if necessary.
7. Reassemble in reverse order.
8. Refill the boiler. Refer to Frame 30.
9. Check Operation of the boiler. Refer to Frames 40 & 41.



## 76 NO FLOW THERMISTOR REPLACEMENT

1. Refer to Frame 50.
2. Drain down the boiler. Refer to Frame 65.
3. Unplug the electrical lead.
4. Unscrew the thermistor (to facilitate removal a 13mm socket spanner should be used).
5. Fit the new thermistor using the sealing washer provided.
6. Reassemble in the reverse order.
7. Refill the boiler. Refer to Frame 30.
8. Check the operation of the boiler. Refer to Frames 40 & 41.

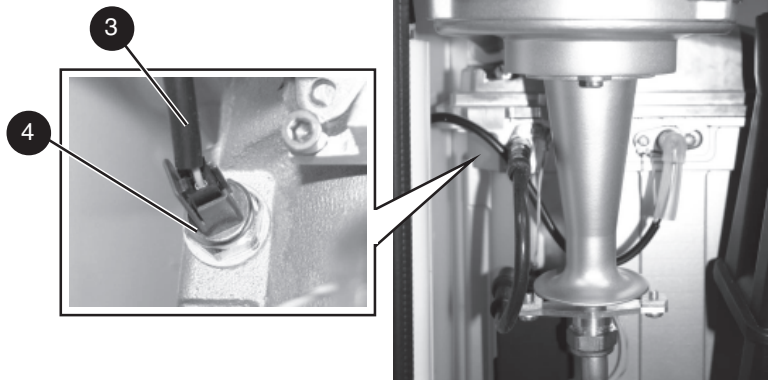

## 77 HEAT ENGINE RENEWAL

Refer also to Frames 6 & 7 - 'Boiler Exploded View'

### IMPORTANT

Before starting the removal procedure, protect the gas and electrical controls with a waterproof sheet or plastic bag.

1. Refer to Frame 50.
2. Drain the boiler. Refer to Frame 65.
3. Remove the fan / venturi assembly and place on one side. Refer to frame 51.
4. Remove the burner and place on one side. Refer to Frame 53.
5. Remove the ignition and detection electrodes and diverter actuator head. Refer to Frames 56, 57 and 60.
6. Remove the spark generator. Refer to Frame 58.
7. Remove the gas valve. Refer to Frame 59.
8. Remove the expansion vessel. Refer to Frame 78.
9. Remove the no flow thermistor. Refer to Frame 76.
10. Remove the 2 M5 screws retaining the gas valve mounting bracket and transfer bracket to the new heat exchanger.
11. Undo the inlet pipe union nut and remove the retaining spring clip and remove pipe.
12. Undo the flow pipe union nut and remove pipe.
13. Remove the condensate rubber pipe. Refer to Frame 61, no. 2.
14. Remove the two heat exchanger fixing screws.
15. Remove the Heat exchanger.
16. Reassemble in reverse order, ensuring the heat exchanger LH retaining bracket is correctly positioned. Replace any new 'o' rings supplied with new heat exchanger and replacing gaskets or seals if any sign of damage is evident. When replacing the spring clips located on both the flow and return pipe connections, ensure clip is oriented to correctly match connecting pipe diameters.
17. Ensure the trap/siphon is filled with water. Refer to Frame 61.
18. Refill the boiler. Refer to Frame 30.
19. Check operation of the boiler. Refer to Frames 40 & 41.

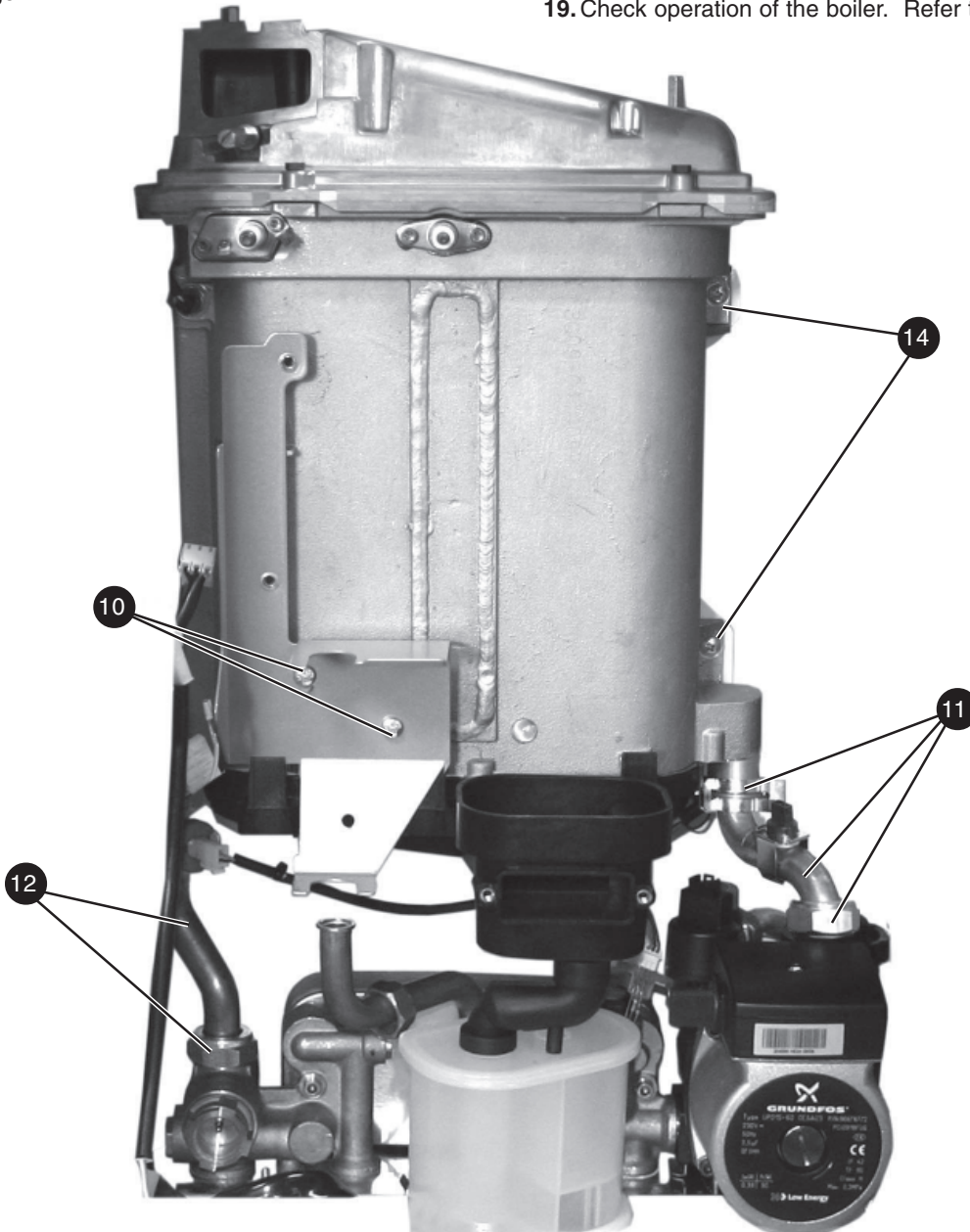

## 78 EXPANSION VESSEL RECHARGING & REPLACEMENT

### RECHARGING

1. Refer to Frame 50.
2. Remove the charge point cover.
3. Recharge the tank pressure to 0.75 bar.
4. Re-assemble in reverse order
5. Check operation of the boiler. Refer to Frames 40 & 41.

### REPLACEMENT

6. Refer to Frame 50.
7. Drain the boiler CH circuit. Refer to Frame 65.
8. Unscrew the union nut on the vessel water connection pipe.
9. Support the expansion vessel and unscrew the 2 screws from the securing clamp, located on the top of the boiler, and remove. (Note the position of the bracket on the vessel)
10. Remove the expansion vessel.
11. Fit the new expansion vessel.
12. Reassemble in reverse order.
13. Refill the boiler. Refer to Frame 30.
14. Check operation of the boiler. Refer to Frames 40 & 41.

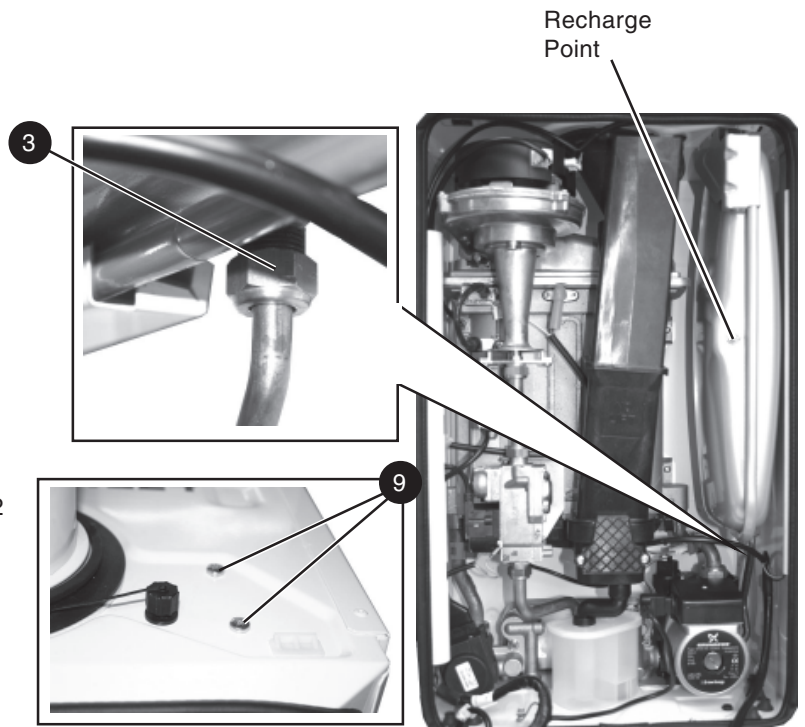

## 79 BOILER SEALING PANEL SEAL REPLACEMENT

1. Refer to Frame 50.
2. Remove the old seal from the casing and thoroughly clean the casing surfaces.
3. Fit the new seal, ensuring the bottom joint provides an air tight seal.
5. Reassemble in reverse order.
6. Check operation of the boiler. Refer to Frames 40 & 41.

**Note.** *Ensure that the boiler front panel is correctly sealed, compressing the seal to make an airtight joint.*

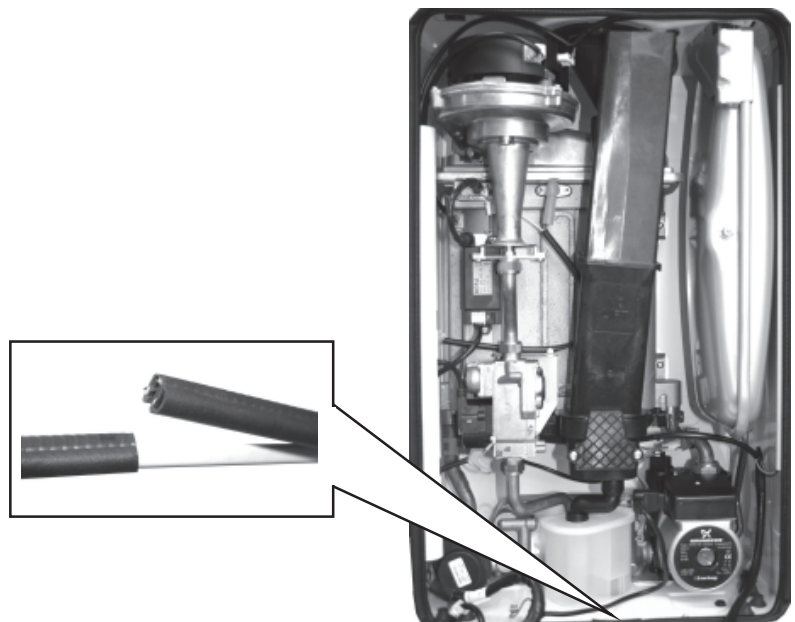

# FAULT FINDING

## 80 FAULT FINDING CHART MAIN MENU

*Note. Boiler status display information is shown in shaded boxes below. Up to six messages will be displayed in rotation.*

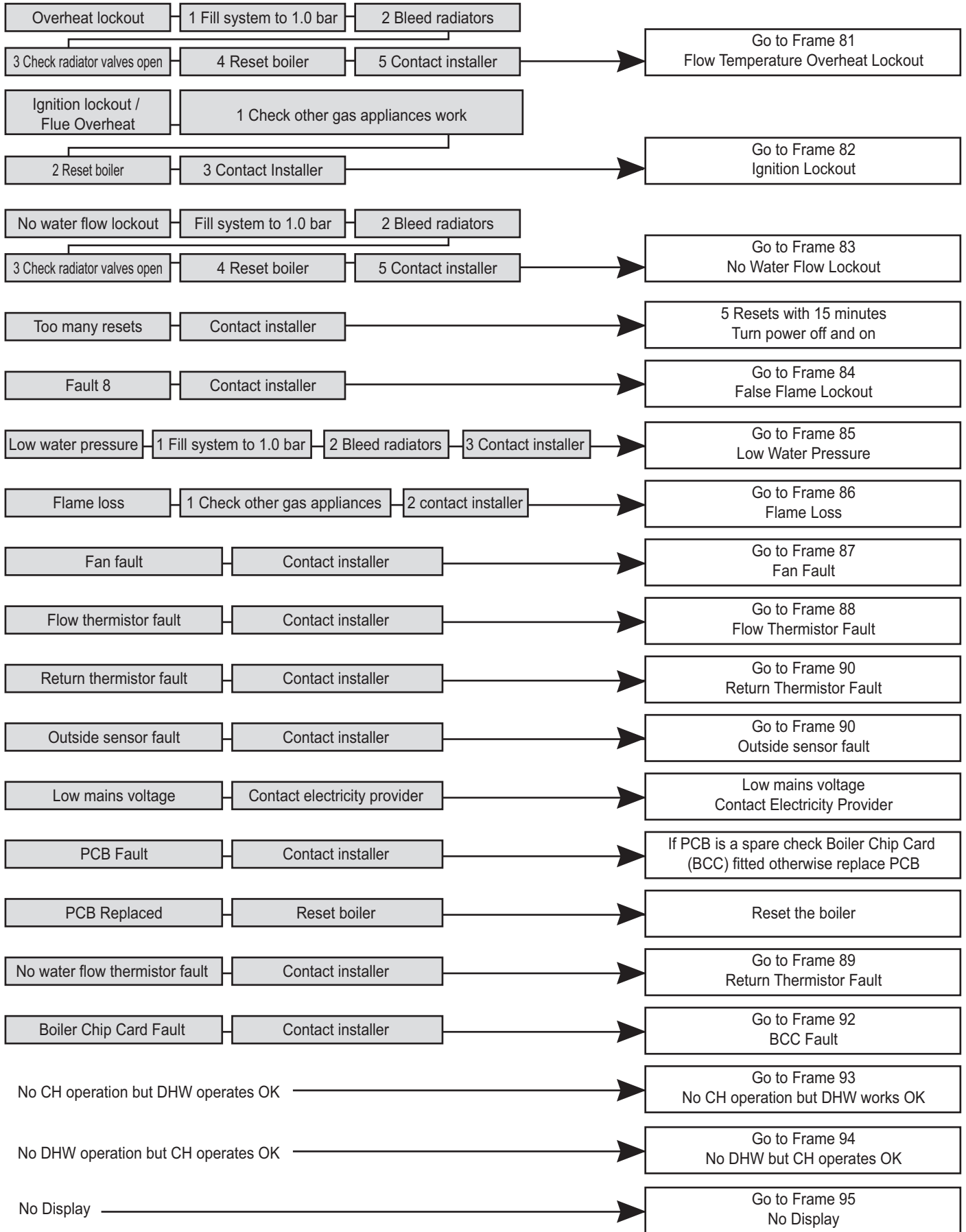

**RESET PROCEDURE** - To reset boiler, turn mode knob to reset position and immediately turn knob back to required setting.



## FAULT FINDING

### 81 OVERHEAT LOCKOUT - 1 FILL SYSTEM TO 1.0 BAR - 2 BLEED RADIATORS - 3 CHECK RADIATOR VALVES OPEN - 4 RESET BOILER - 5 CONTACT INSTALLER

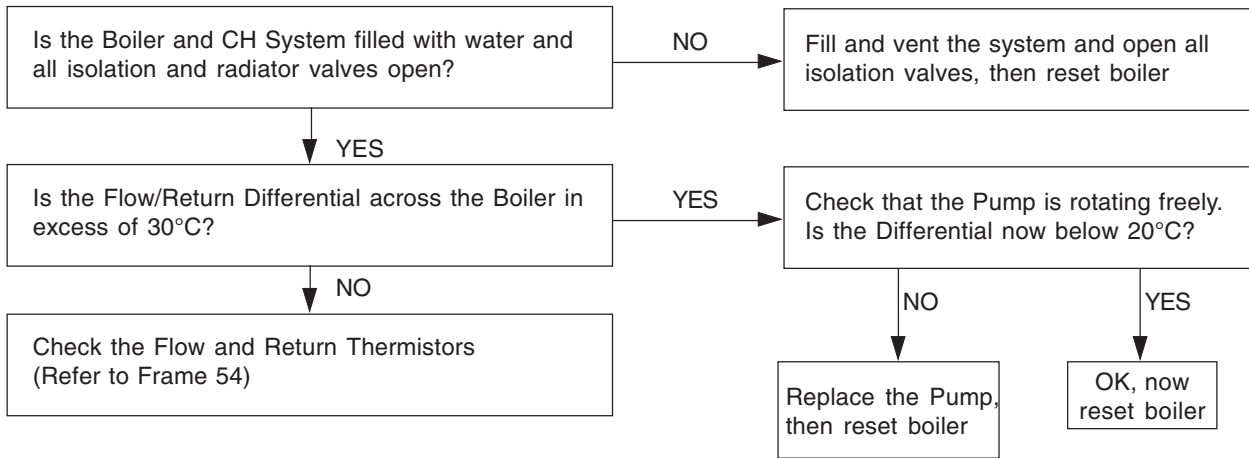

**RESET PROCEDURE** - To reset boiler, turn mode knob to reset position and immediately turn knob back to required setting.

## FAULT FINDING

### 82 IGNITION LOCKOUT / FLUE OVERHEAT - 1 CHECK OTHER GAS APPLIANCES WORK - 2 RESET BOILER - 3 CONTACT INSTALLER

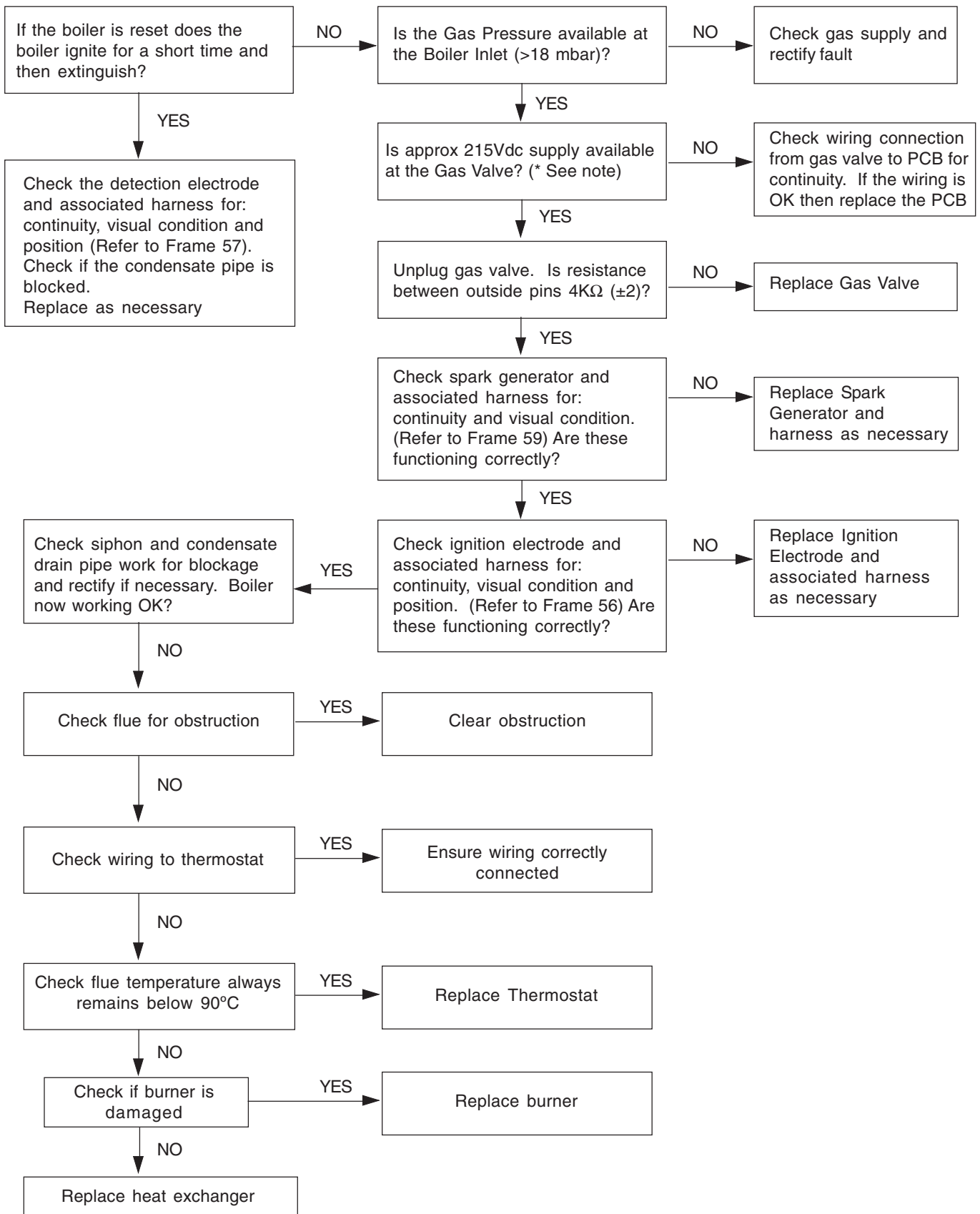

**\* Note:** due to the wave form of the rectified voltage, the reading will vary depending on the type of meter used to measure the value. In general terms a reading greater than 150V indicates that the correct voltage is supplied to the gas valve.

**RESET PROCEDURE** - To reset boiler, turn mode knob to reset position and immediately turn knob back to required setting.

## FAULT FINDING

### 83 NO WATER FLOW LOCKOUT - 1 FILL SYSTEM TO 1.0 BAR - 2 BLEED RADIATORS - 3 CHECK RADIATOR VALVES OPEN - 4 RESET BOILER - 5 CONTACT INSTALLER

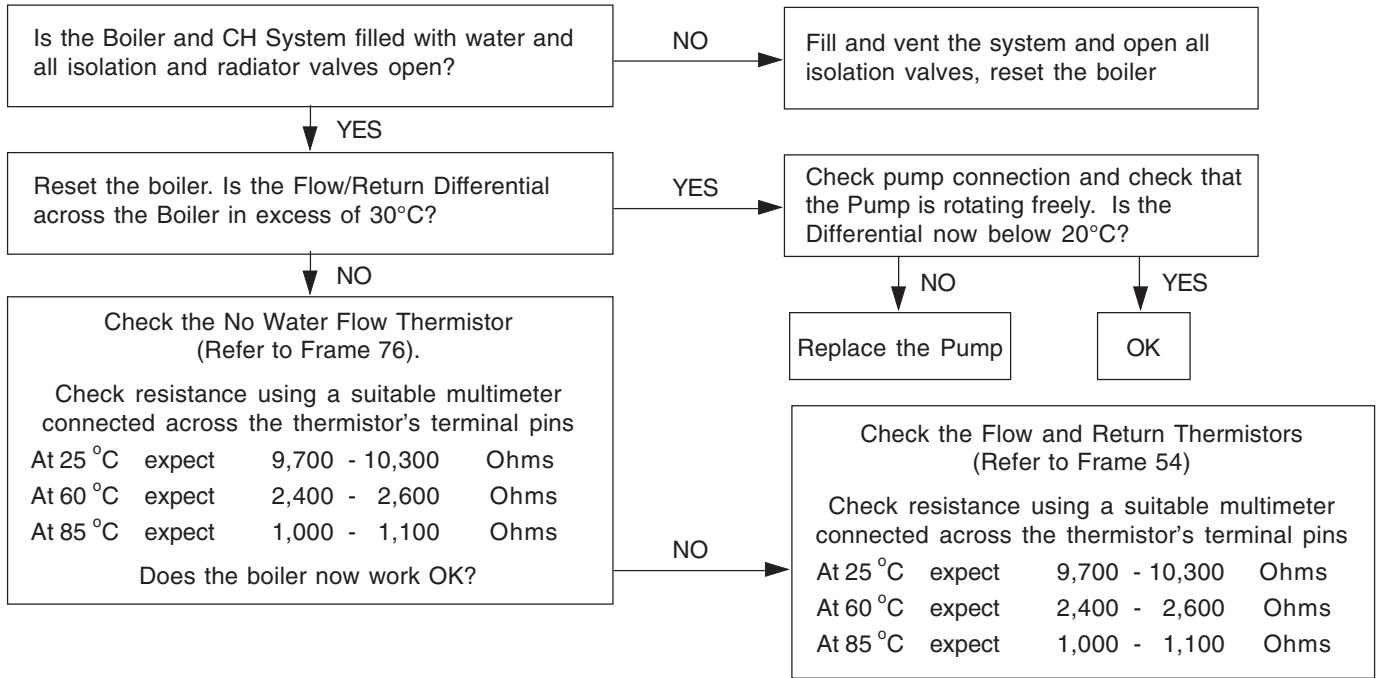

**RESET PROCEDURE** - To reset boiler, turn mode knob to reset position and immediately turn knob back to required setting.

### 84 FAULT 8 - CONTACT INSTALLER (FALSE FLAME LOCKOUT)

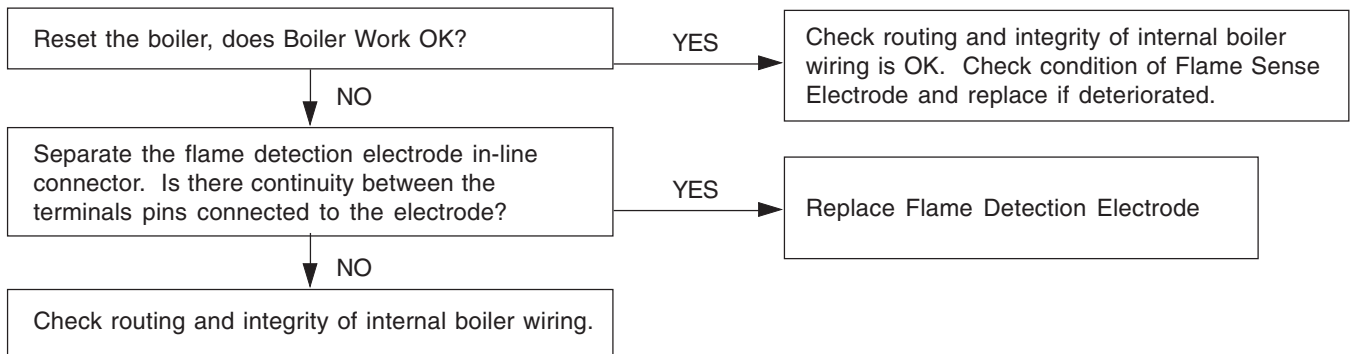

**RESET PROCEDURE** - To reset boiler, turn mode knob to reset position and immediately turn knob back to required setting.

### 85 LOW WATER PRESSURE - 1 FILL SYSTEM TO 1.0 BAR - 2 BLEED RADIATORS - 3 CONTACT INSTALLER

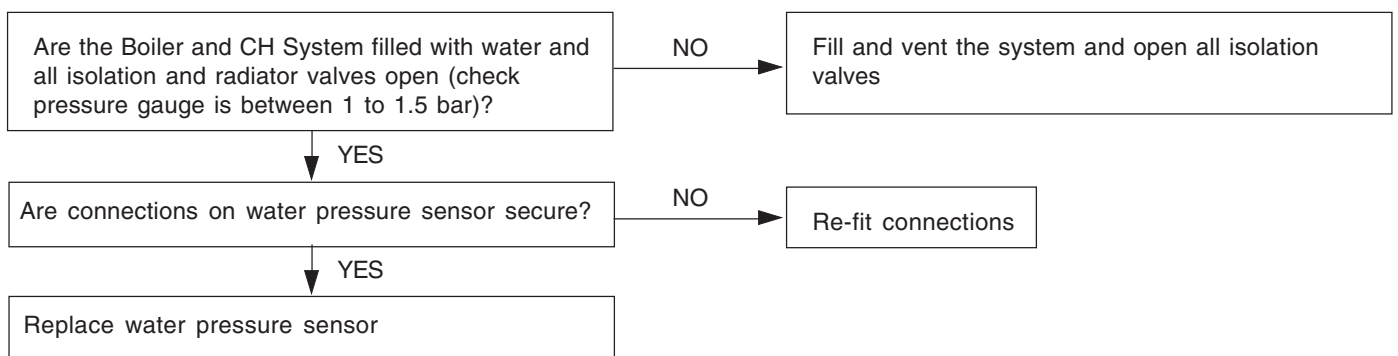

## FAULT FINDING

### 86 FLAME LOSS - 1 CHECK OTHER GAS APPLIANCES WORK - 2 CONTACT INSTALLER

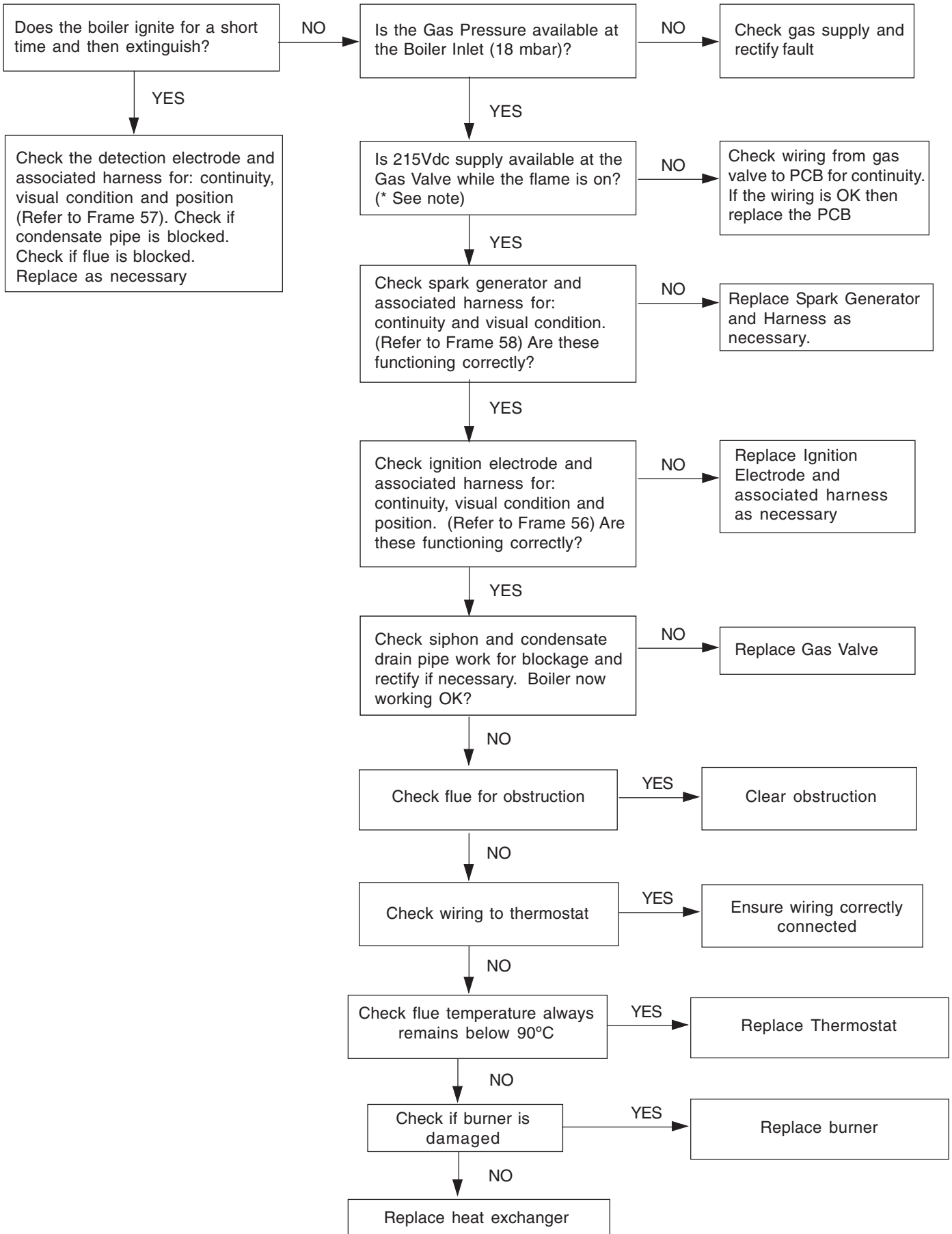

*\* Note: due to the wave form of the rectified voltage, the reading will vary depending on the type of meter used to measure the value. In general terms a reading greater than 150V indicates that the correct voltage is supplied to the gas valve.*

## FAULT FINDING

### 87 FAN FAULT - CONTACT INSTALLER

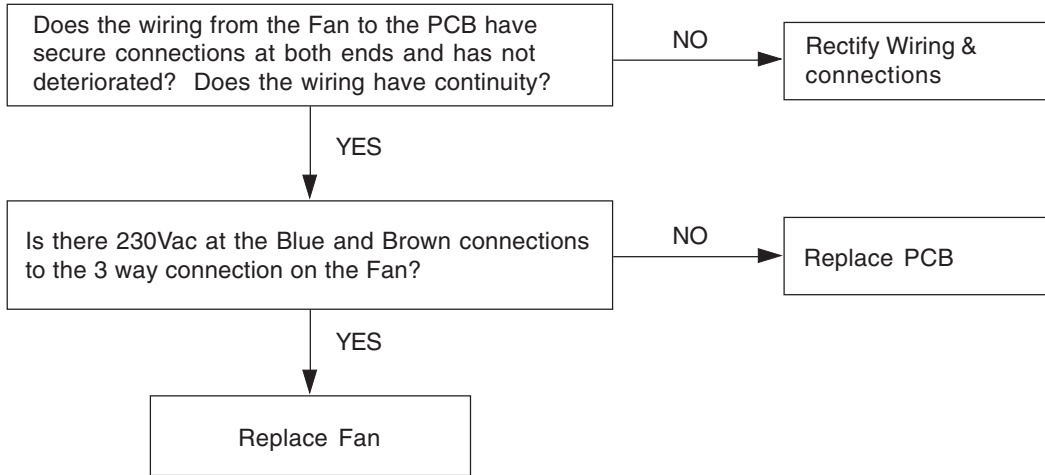

### 88 FLOW THERMISTOR FAULT - CONTACT INSTALLER

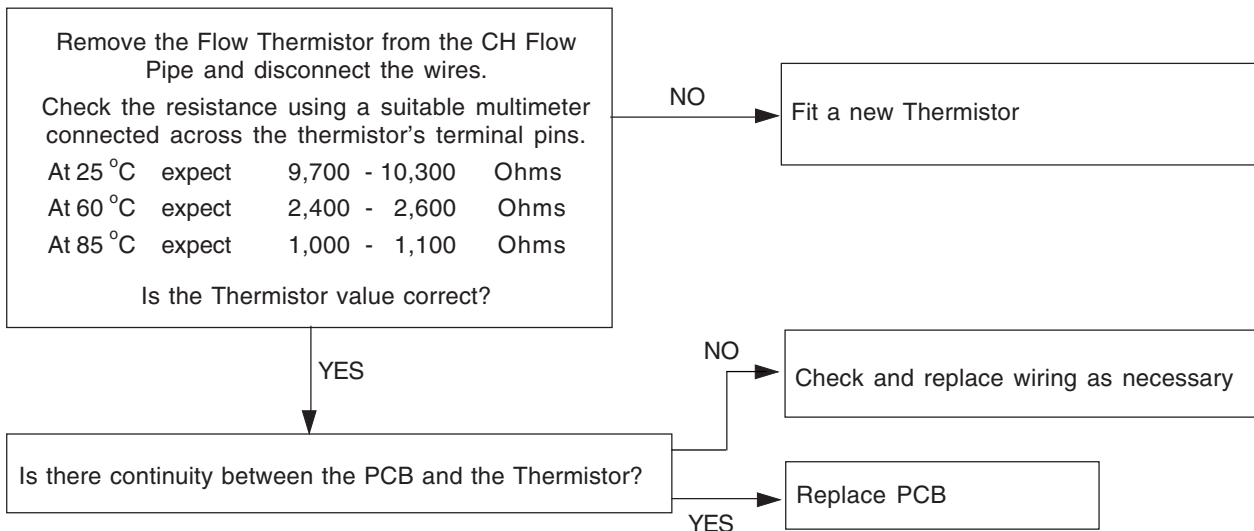

### 89 RETURN THERMISTOR FAULT - CONTACT INSTALLER

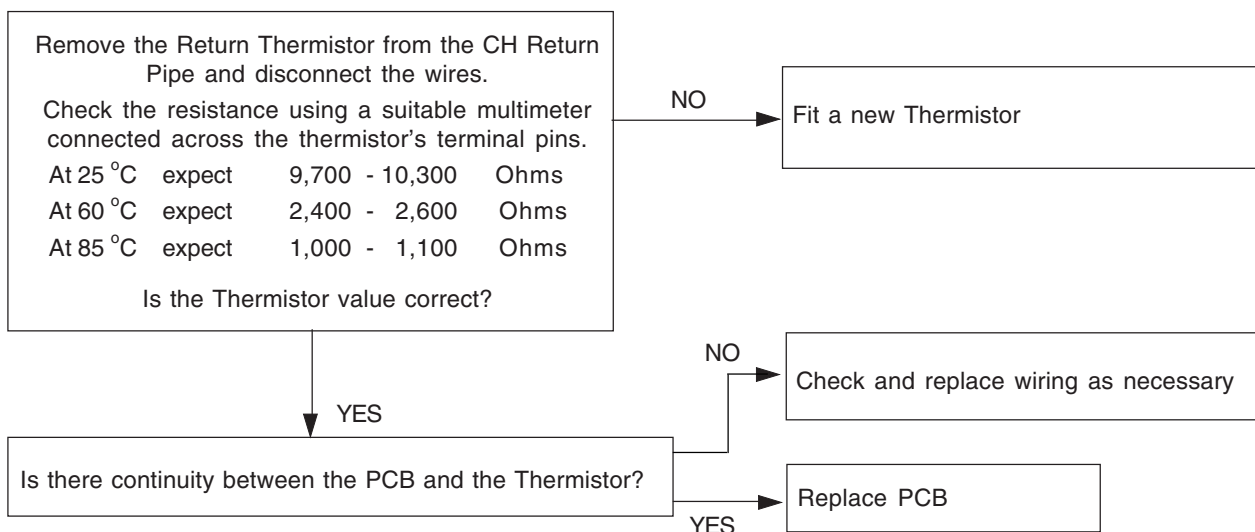



## FAULT FINDING

### 92 BOILER CHIP CARD FAULT - CONTACT INSTALLER

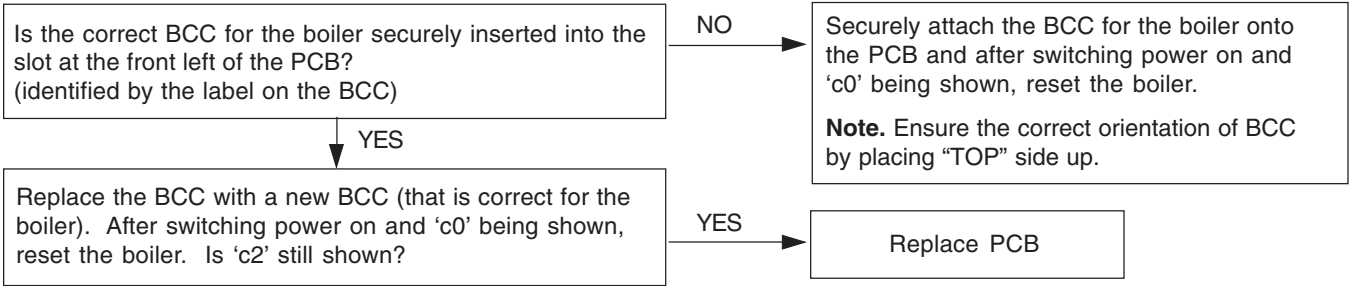

**RESET PROCEDURE** - To reset boiler, turn mode knob to reset position and immediately turn knob back to required setting.

### 93 NO CH OPERATION BUT DHW WORKS OK

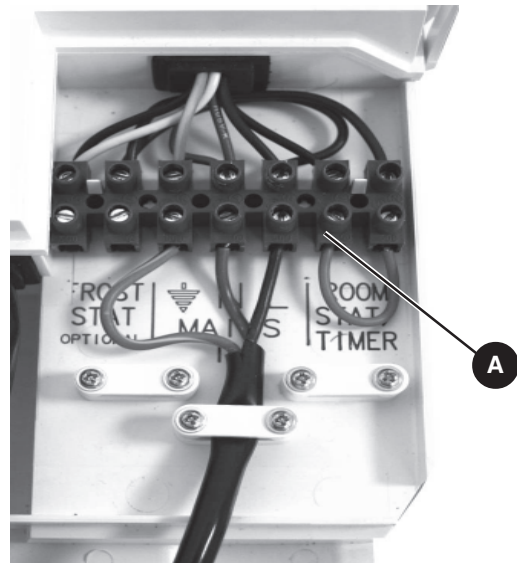
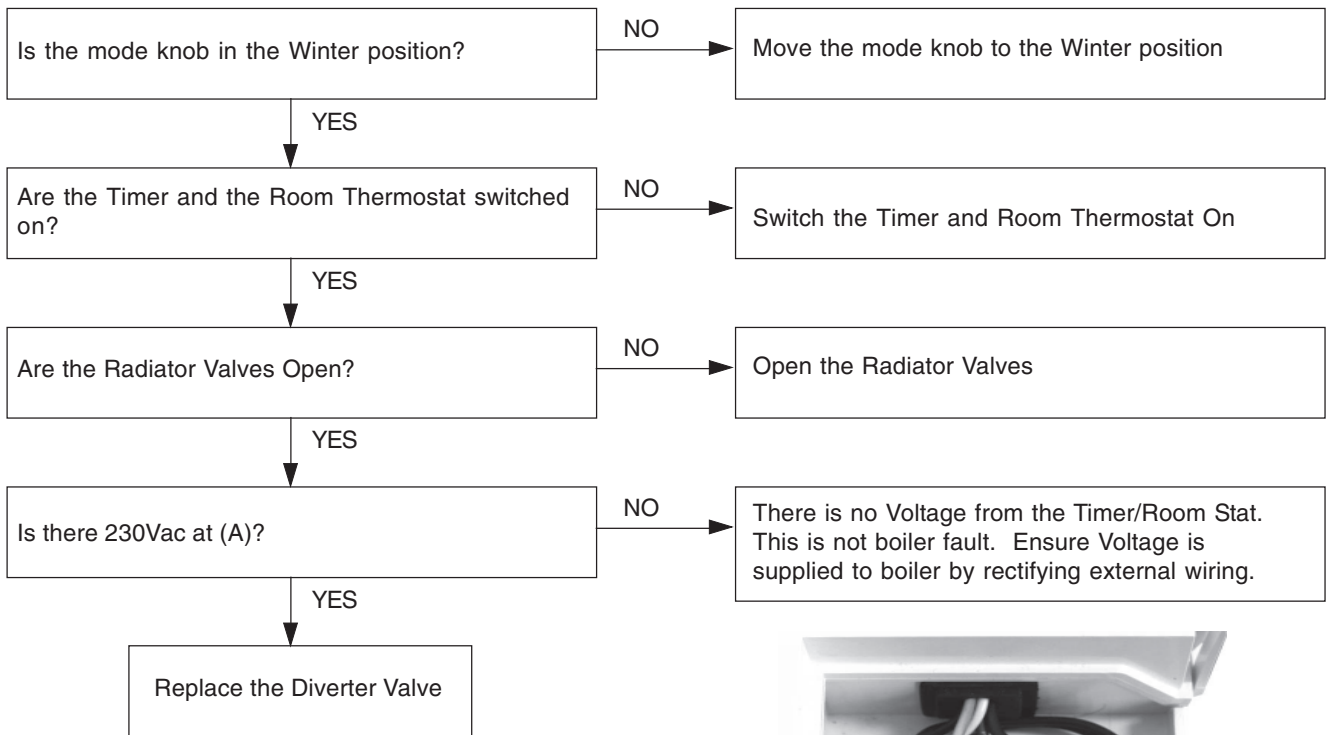





## SHORT LIST OF PARTS

The following are parts commonly required due to damage or expendability. Their failure or absence is likely to affect safety or performance of this appliance.

The list is extracted from the British Gas List of Parts, which contains all available spare parts.

The full list is held by British Gas Services, Keston distributors and merchants.

When ordering spares please quote:

1. Boiler model
2. Appliance G.C. No.
3. Description.
4. Quantity.
5. Product number.

When replacing any part on this appliance use only spare parts that you can be assured conform to the safety and performance specification that we require. Do not use reconditioned or copy parts that have not been clearly authorised by Keston.

Key No.	G.C. Part No.	Description	Qty./boiler	Product Number
107		Filling Loop	1	KS301175530
108		Pump Head Kit	1	KS301175670
110		Automatic Air Vent	1	KS301174894
111		Diverter Valve Head	1	KS301174813
112		Diverter Valve Cartridges	1	KS301175668
113		Pressure Relief Valve	1	KS301175413
118		Expansion Vessel	1	KS301175551
121		Plate Heat Exchanger	1	KS301175418
127		Flow Sensor (Hall Effect)	1	KS301175590
128		DHW Flow Turbine	1	KS301175661
131		Water Pressure Sensor	1	KS301175596
135		Pressure Gauge	1	KS301175679
205		Gas Valve kit	1	KS301175562
211		Injector & Housing	1	KS301175611
215		Fan Kit	1	KS301175569
217		Burner	1	KS301175571
229		Siphon Trap Kit	1	KS301175583
232		Turret Manifold Gasket	1	KS301175620
302		Primary PCB	1	KS301175939
302B		Boiler Chip Card (BCC)	1	KS301175937
303		CUI Board	1	KS301175713
304		Control Thermistor (Flow/Return)	2	KS301175589
306		Ignition Electrode Kit	1	KS301175591
307		Detection Electrode Kit	1	KS301175592
308		Spark Generator	1	KS301175593
309		Thermistor - No Flow	1	KS301175594
313		Ignition lead	1	KS301175598
320		Detection Lead	1	KS301175604
328		Fuse - PCB	1	KS301175627
403		Heat Engine Gasket Kit	1	KS301175618
504		Front Panel	1	KS301175723
512		Front Panel Door	1	KS301175722
332		Flue Thermostat	1	KS301175949

# SHORT LIST OF PARTS

## 96 SHORT LIST

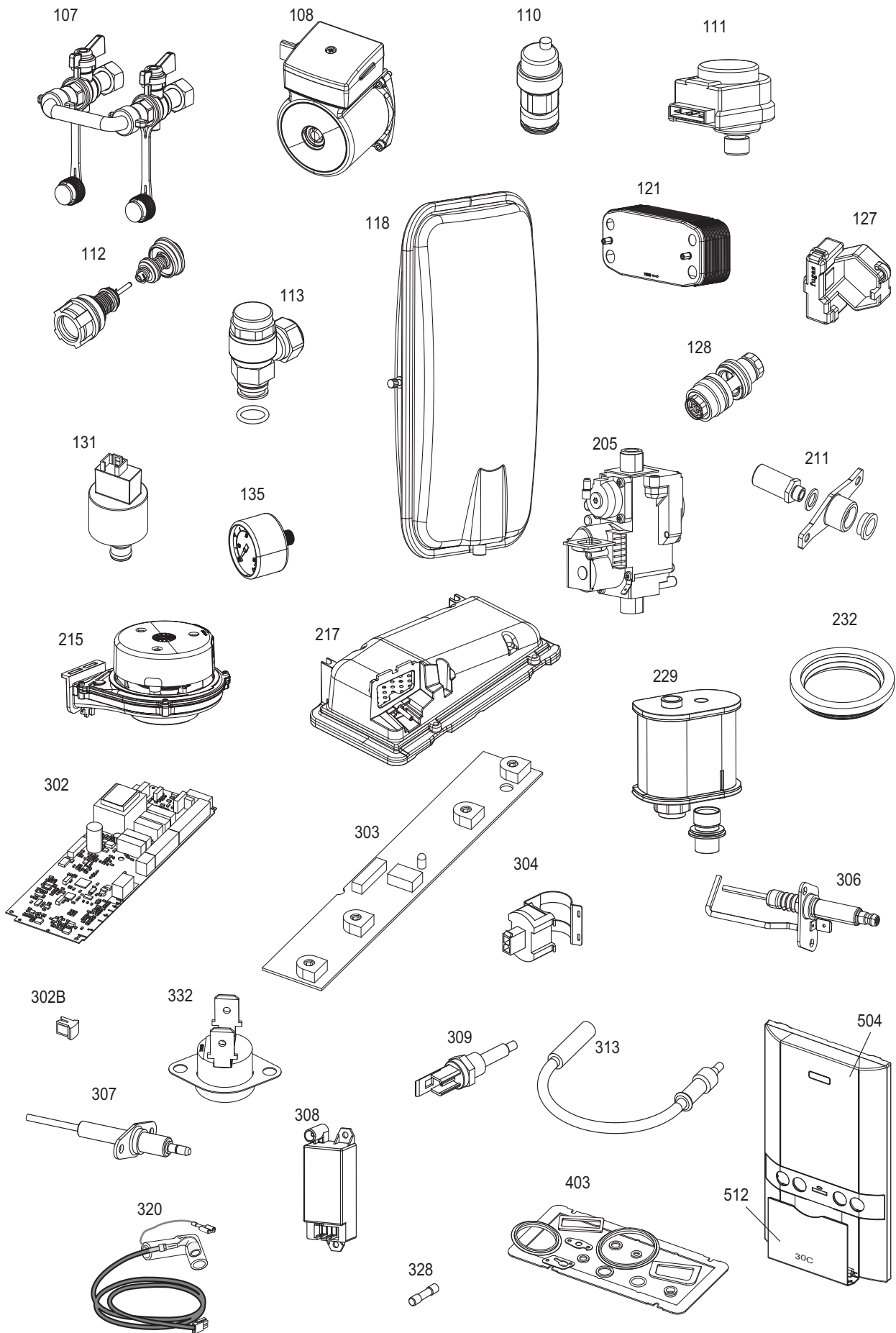

3G9977a

# Code Of Practice

For the installation, commissioning and servicing of domestic heating and hot water products

Benchmark places responsibilities on both manufacturers and installers.\* The purpose is to ensure that customers\*\* are provided with the correct equipment for their needs, that it is installed, commissioned and serviced in accordance with the manufacturer's instructions by competent persons and that it meets the requirements of the appropriate Building Regulations. Installers are required to carry out work in accordance with the following:

## Standards of Work

- Be competent and qualified to undertake the work required.
- Install, commission, service and use products in accordance with the manufacturer's instructions provided.
- Ensure that where there is responsibility for design work, the installation is correctly sized and fit for purpose.
- Meet the requirements of the appropriate Building Regulations. Where this involves notifiable work be a member of a Competent Persons Scheme or confirm that the customer has notified Local Authority Building Control (LABC), prior to work commencing.
- Complete all relevant sections of the Benchmark Checklist/Service Record when carrying out commissioning or servicing of a product or system.
- Ensure that the product or system is left in a safe condition and, whenever possible, in good working order.
- Highlight to the customer any remedial or improvement work identified during the course of commissioning or servicing work.
- Refer to the manufacturer's helpline where assistance is needed.
- Report product faults and concerns to the manufacturer in a timely manner.

## Customer Service

- Show the customer any identity card that is relevant to the work being carried out prior to commencement or on request.
- Give a full and clear explanation/demonstration of the product or system and its operation to the customer.
- Hand over the manufacturer's instructions, including the Benchmark Checklist, to the customer on completion of an installation.
- Obtain the customer's signature, on the Benchmark Checklist, to confirm satisfactory demonstration and receipt of manufacturer's instructions.
- Advise the customer that regular product servicing is needed, in line with manufacturers' recommendations, to ensure that safety and efficiency is maintained.
- Respond promptly to calls from a customer following completion of work, providing advice and assistance by phone and, if necessary, visiting the customer.
- Rectify any installation problems at no cost to the customer during the installer's guarantee period.



\*The use of the word "installer" is not limited to installation itself and covers those carrying out installation, commissioning and/or servicing of heating and hot water products, or the use of supporting products (such as water treatment or test equipment).

\*\*Customer includes householders, landlords and tenants.

# INSTALLER NOTIFICATION GUIDELINES

A change to Building Regulations (England and Wales) requires the installer to notify when installing a heating appliance, as from 1st April 2005.

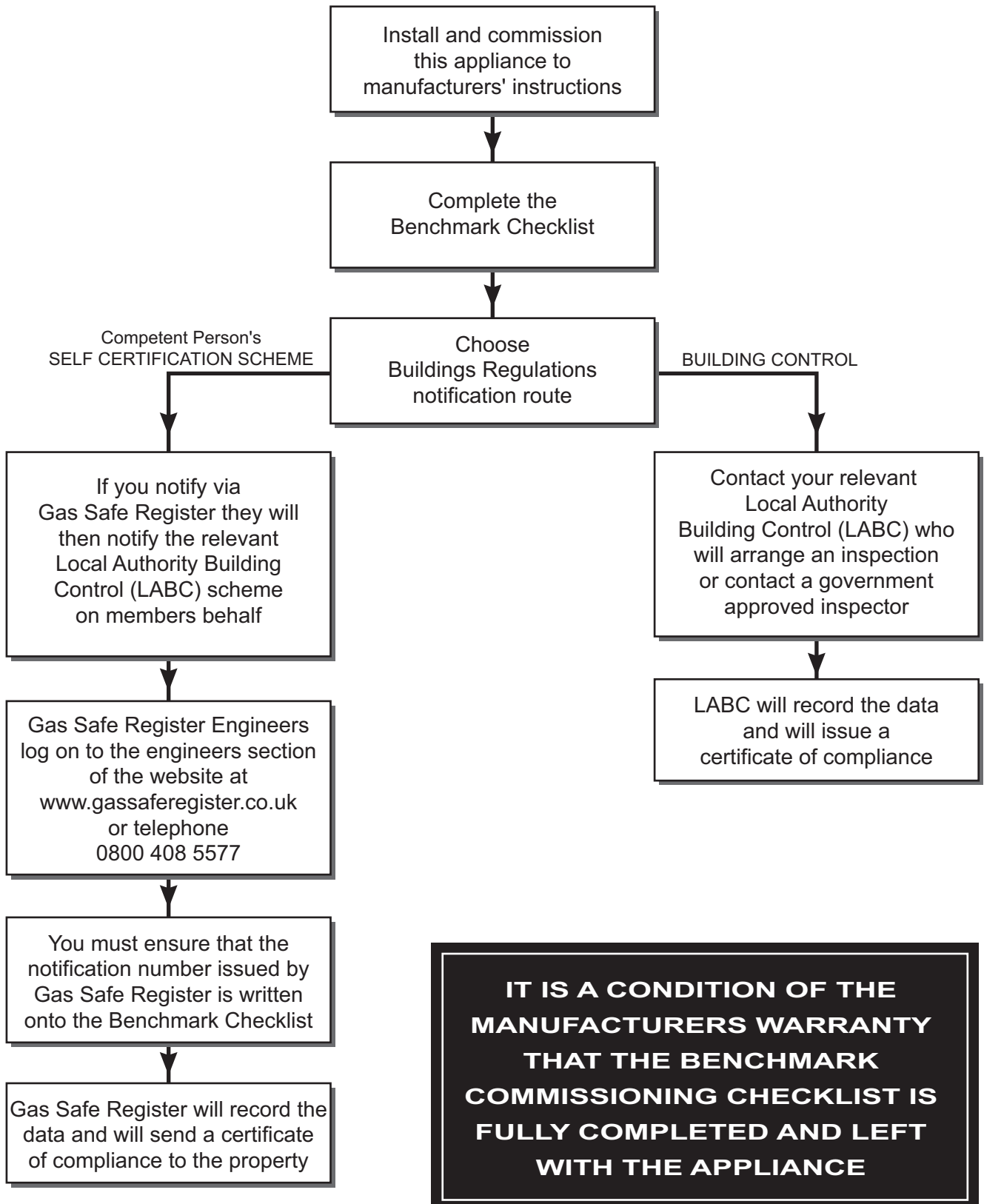

**THIS PAGE INTENTIONALLY LEFT BLANK**



# SERVICE RECORD

It is recommended that your heating system is serviced regularly and that the appropriate Service Record is completed.

## Service Provider

Before completing the appropriate Service Record below, please ensure you have carried out the service as described in the manufacturer's instructions.

Always use the manufacturer's specified spare part when replacing controls.

### SERVICE 1

Date

Energy Efficiency Checklist completed?

Yes  No

Engineer Name

Company Name

Telephone Number

Gas Safe Register ID Number

Comments

Signature

### SERVICE 2

Date

Energy Efficiency Checklist completed?

Yes  No

Engineer Name

Company Name

Telephone Number

Gas Safe Register ID Number

Comments

Signature

### SERVICE 3

Date

Energy Efficiency Checklist completed?

Yes  No

Engineer Name

Company Name

Telephone Number

Gas Safe Register ID Number

Comments

Signature

### SERVICE 4

Date

Energy Efficiency Checklist completed?

Yes  No

Engineer Name

Company Name

Telephone Number

Gas Safe Register ID Number

Comments

Signature

### SERVICE 5

Date

Energy Efficiency Checklist completed?

Yes  No

Engineer Name

Company Name

Telephone Number

Gas Safe Register ID Number

Comments

Signature

### SERVICE 6

Date

Energy Efficiency Checklist completed?

Yes  No

Engineer Name

Company Name

Telephone Number

Gas Safe Register ID Number

Comments

Signature

### SERVICE 7

Date

Energy Efficiency Checklist completed?

Yes  No

Engineer Name

Company Name

Telephone Number

Gas Safe Register ID Number

Comments

Signature

### SERVICE 8

Date

Energy Efficiency Checklist completed?

Yes  No

Engineer Name

Company Name

Telephone Number

Gas Safe Register ID Number

Comments

Signature

### SERVICE 9

Date

Energy Efficiency Checklist completed?

Yes  No

Engineer Name

Company Name

Telephone Number

Gas Safe Register ID Number

Comments

Signature

### SERVICE 10

Date

Energy Efficiency Checklist completed?

Yes  No

Engineer Name

Company Name

Telephone Number

Gas Safe Register ID Number

Comments

Signature

**Keston Boilers**, 34 West Common Road, Hayes, Bromley, Kent, BR2 7BX.  
Telephone: 0208 462 0262 Fax: 0208 462 4459.

June 2010 UIN 205531 A03

**KESTON**

**Keston** pursues a policy of continuing improvement in the design and performance of its products. The right is therefore reserved to vary specification without notice.