

Installation Manual

Gas condensing boiler

Eurocondense five 400 kW
Eurocondense five 470 kW
Eurocondense five 540 kW
Eurocondense five 610 kW

Dear Customer,

Thank you very much for buying this appliance.

Please read through the manual carefully before using the product, and keep it in a safe place for later reference. In order to ensure continued safe and efficient operation we recommend that the product is serviced regularly. Our service and customer service organisation can assist with this.

We hope you enjoy years of problem-free operation with the product.

Contents

1	Safety	7
1.1	General safety instructions	7
1.2	Intended use	9
1.3	Liabilities	10
1.3.1	Manufacturer's liability	10
1.3.2	Installer's liability	10
1.3.3	User's liability	10
2	About this manual	11
2.1	General	11
2.2	Additional documentation	11
2.3	Symbols used	11
2.3.1	Symbols used in the manual	11
3	Technical specifications	13
3.1	Homologations	13
3.1.1	Regulations and standards	13
3.1.2	Manufacturer's Declaration	13
3.2	Technical data	14
3.2.1	Technical data – Boiler space heaters in accordance with ErP guideline	14
3.2.2	Technical data	14
3.2.3	Technical data for the auxiliary contactor for the pump PHS	15
3.2.4	Tables of sensor values	16
3.2.5	Pressure drop secondary circuit	17
3.2.6	Dimensions and connections	18
3.2.7	Wiring diagram	20
4	Description of the product	22
4.1	Operating principle	22
4.1.1	Description of the function of the air pressure monitor	22
4.1.2	Circulating pump	22
4.2	Main components	23
4.2.1	Boiler	23
4.3	Control panel description	24
4.3.1	Operating elements	24
4.3.2	Displays	24
4.4	Accessories and options	24
4.4.1	Room device RGP	24
4.4.2	Installation of extension modules	25
5	Before installation	26
5.1	Regulations governing installation	26
5.2	Corrosion protection	26
5.3	Supply air openings	26
5.4	Treating and preparing the heating water	26
5.4.1	Introduction	26
5.4.2	Protecting the heat generator	26
5.5	Heating water requirements	27
5.5.1	Addition of a product to treat the heating water	28
5.5.2	Softening/partial softening	28
5.5.3	Full desalination/partial desalination	29
5.5.4	Maintenance	30
5.6	Determining the system volume	30
5.7	Practical information for qualified heating specialists	30
5.8	Use of antifreeze agents with Potterton heat generators	30
5.9	Choice of the location	32
5.9.1	Notes for installation location	32
5.9.2	Combustion air openings	32
5.9.3	Space requirement	33
5.10	Transport	34
5.10.1	General	34
5.10.2	Unpacking	34
5.10.3	Moving by crane	35
5.10.4	Moving by one pallet truck	35

5.10.5	Moving by two pallet trucks	36
5.10.6	Transport on rollers	36
5.10.7	Moving the boiler in tight spaces	37
5.11	Connecting diagrams	40
5.11.1	Application examples	40
5.11.2	Legend	44
6	Installation	46
6.1	General	46
6.2	Assembly	46
6.2.1	Positioning and levelling the boiler	46
6.2.2	Mounting the cover panels for transport openings	47
6.2.3	Installing siphon and condensate piping	47
6.2.4	Converting the flue gas connection	49
6.2.5	Flue gas connections and air supply ducts	51
6.3	Hydraulic connections	52
6.3.1	Connecting the heating circuit	52
6.3.2	Safety valve	52
6.3.3	Condensate connection	52
6.4	Gas connection	53
6.4.1	Gas connection	53
6.4.2	Check tightness	53
6.4.3	Venting the gas line	53
6.5	Air supply/flue gas outlet connections	54
6.5.1	Cleaning and inspection openings	54
6.6	Electrical connections	54
6.6.1	Electrical connection (general)	54
6.6.2	Cable lengths	55
6.6.3	Strain reliefs	55
6.6.4	Circulating pumps	55
6.6.5	Appliance fuses	55
6.6.6	Connecting sensors/components	55
6.6.7	Replacing cables	56
6.6.8	Protection against contact	56
6.6.9	Electrical connection of the auxiliary contactor for the pump PHS	56
6.7	Filling the system	57
7	Commissioning	58
7.1	General	58
7.2	Checklist for commissioning	58
7.3	Commissioning procedure	59
7.3.1	Commissioning menu	59
7.4	Gas settings	59
7.4.1	Factory settings	59
7.4.2	CO ₂ content	59
7.4.3	Manual adjustment of burner output (controller stop function)	59
7.4.4	Adjusting CO ₂ content	60
7.5	Final instructions	61
7.5.1	Instruction of the customer	61
7.5.2	Documents	62
8	Operation	63
8.1	Use of the control panel	63
8.1.1	Changing parameters	63
8.1.2	Programming procedure	64
8.2	Start-up	64
8.2.1	Checking water pressure	64
8.2.2	Switching on	64
8.2.3	Setting necessary parameters	65
8.2.4	Setting the heating mode	65
8.2.5	Adjusting domestic water mode	66
8.2.6	Adjusting comfortable room setpoint	66
8.2.7	Setting reduced room setpoint	66
8.2.8	Emergency mode (Manual control)	66
8.2.9	Chimney sweep function	67
8.2.10	Restoring factory settings	67

9	Settings	68
9.1	List of parameters	68
9.2	Description of the parameters	90
9.2.1	Time and date	90
9.2.2	Operator section	90
9.2.3	Wireless	92
9.2.4	Time programs	92
9.2.5	Holiday programs	93
9.2.6	Heating circuits	93
9.2.7	Domestic water	100
9.2.8	Consumer circuits/swimming pool circuit	103
9.2.9	Swimming pool	103
9.2.10	Primary contr/system pump	104
9.2.11	Boiler	104
9.2.12	Cascade	108
9.2.13	Solar	109
9.2.14	Solid fuel boiler	112
9.2.15	Buffer storage tank	112
9.2.16	DHW storage tank	114
9.2.17	Configuration	119
9.2.18	LPB system	126
9.2.19	Modbus	128
9.2.20	Fault	128
9.2.21	Maintenance / special operation	128
9.2.22	Configuration of extension modules	131
9.2.23	Input/output test	135
9.2.24	Status	135
9.2.25	Diagnostics cascade/heat generation/consumers	139
9.2.26	Burner control	140
9.2.27	Info option	140
10	Maintenance	141
10.1	General	141
10.1.1	General instructions	141
10.1.2	Inspection and service as required	141
10.1.3	Lifetime of safety-relevant components	142
10.2	Maintenance messages	142
10.2.1	Maintenance message	142
10.2.2	Maintenance code table	142
10.2.3	Operating phases of the Control Centre LMS	142
10.3	Standard inspection and maintenance operations	143
10.3.1	Checking water hardness	143
10.3.2	Cleaning the fan	143
10.3.3	Cleaning the burner pipe	144
10.3.4	Checking and replacing ignition and ionization electrode	145
10.3.5	Cleaning the heat exchanger and siphon	146
10.3.6	Checking CO ₂ content	148
10.3.7	Checking air pressure monitor pipes	148
10.3.8	Filling the system	149
10.3.9	Maintenance of the accessories	149
11	Troubleshooting	150
11.1	Fault code table	150
11.2	Fault finding	152
11.2.1	Fault message	152
11.2.2	Fault switch-off	152
12	Decommissioning	154
12.1	Decommissioning procedure	154
12.1.1	Decommissioning the domestic water storage tank	154
12.1.2	Draining off the heating water	154
13	Disposal/recycling	155
13.1	Packaging	155
13.2	Appliance disposal	155

14 Appendix	156
14.1 Declaration of conformity	156
Index	157

1 Safety

1.1 General safety instructions



Danger

If you smell gas:

1. Do not use a naked flame, do not smoke, do not operate electrical contacts or switches (doorbell, light, motor, lift, etc.).
2. Shut off the gas supply.
3. Open the windows.
4. Trace possible leaks and seal them immediately.
5. If the gas leak is before the gas meter, contact the gas supplier.



Danger

Danger to life.

Observe the warnings affixed to the gas condensing boiler. Incorrect operation of the gas condensing boiler can lead to considerable damage.



Warning

Persons involved in transport must wear protective gloves and safety footwear.



Danger

Commissioning may only be carried out by an approved installer. The installer checks the tightness of pipes, the correct function of all regulating, control and safety equipment, and measures the combustion values. If this work is not carried out correctly, there is a risk of considerable damage to persons, environment and property.



Important

All electrical work must only be carried out by authorized specialists.



Danger

Risk of poisoning.

Never use water from the heating system as drinking water. It is contaminated by deposits.



Danger

Risk of poisoning.

Never use condensate water as drinking water!

- Condensate is not suitable for consumption by people or animals.
- Do not let the skin come into contact with condensate.
- Suitable protective clothing must be worn during maintenance work.



Caution

Danger of freezing!

If there is a danger of freezing do not shut down the heating system; continue to operate it at least in economy mode with radiator valves open. You should only shut down the heating system and drain the boiler, domestic water storage tank and radiators if it is not possible to heat in frost mode.



Caution

Secure against unintentional switch-on!

When the heating system is empty, ensure that the boiler cannot be switched on unintentionally.



Danger

This appliance can be used by children aged from 8 years and above and persons with reduced physical, sensory or mental capabilities or lack of experience and knowledge if they have been given supervision or instruction concerning use of the appliance in a safe way and understand the hazards involved. Children shall not play with the appliance. Cleaning and user maintenance shall not be made by children without supervision.



Danger

The heating system must not continue to be operated if damaged!



Danger

Risk of death due to modifications to the boiler!

Unauthorised conversions and modifications to the boiler are not permitted, as these can put people at risk and cause damage to the boiler. Failure to comply with these instructions renders the approval for the boiler void.

**Danger**

Replacement of damaged parts may only be performed by an installer.

**Warning****Risk of damage!**

The condensing boiler may only be installed in rooms with clean combustion air. Foreign matter such as pollen must never filter through the inlet apertures to reach the inside of the appliance. The boiler must not be started up if there is heavy dust development e.g. during construction work. There could be damage to the boiler.

**Caution****Keep the inflow area clear.**

Never block or close off ventilation apertures. The inflow area for combustion air must be kept clear.

**Danger****Danger to life due to explosion/fire.**

Do not store any explosive or easily flammable materials close to the appliance.

**Caution****Risk of burns!**

For safety reasons, the discharge pipe from the safety valve must always be open so that water can escape during heating operation. The operating state of the safety valve must be checked from time to time.

1.2 Intended use

The gas condensing boilers of the EC five series are intended to be used according to DIN EN 12828 as heat generators in domestic water heating systems.

They conform to DIN EN 15502-1:2015-10 and DIN EN 15502-2-1:2017-09, Installation type B₂₃, B_{23P}, C₃₃, C₅₃, C₆₃, C₈₃ and C₉₃.

Country of destination GB: Category I_{2H}

1.3 Liabilities

1.3.1 Manufacturer's liability

Our products are manufactured in compliance with the requirements of the various Directives applicable. They are therefore delivered with the CE marking and any documents necessary. In the interests of the quality of our products, we strive constantly to improve them. We therefore reserve the right to modify the specifications given in this document.

Our liability as manufacturer may not be invoked in the following cases:

- Failure to abide by the instructions on installing and maintaining the appliance.
- Failure to abide by the instructions on using the appliance.
- Faulty or insufficient maintenance of the appliance.

1.3.2 Installer's liability

The installer is responsible for the installation and initial commissioning of the appliance. The installer must observe the following instructions:

- Read and follow the instructions given in the manuals provided with the appliance.
- Install the appliance in compliance with prevailing legislation and standards.
- Carry out initial commissioning and any checks necessary.
- Explain the installation to the user.
- If maintenance is necessary, warn the user of the obligation to check the appliance and keep it in good working order.
- Give all the instruction manuals to the user.

1.3.3 User's liability

To guarantee optimum operation of the system, you must abide by the following instructions:

- Read and follow the instructions given in the manuals provided with the appliance.
- Call on a qualified professional to carry out installation and initial commissioning.
- Get your installer to explain your installation to you.
- Have the required inspections and maintenance carried out by a qualified installer.
- Keep the instruction manuals in good condition close to the appliance.

2 About this manual

2.1 General

This manual is intended for the installer of a EC five boiler.

2.2 Additional documentation

Here is an overview of the further documents belonging to this heating system.

Tab.1 Overview table

Documentation	Contents	Intended for
Technical information	<ul style="list-style-type: none"> • Planning documents • Description of function • Technical data/circuit diagrams • Basic equipment and accessories • Application examples • Call-for-tender texts 	Planner, installer, customer
Installation manual – Extended information	<ul style="list-style-type: none"> • Intended use • Technical data/circuit diagram • Regulations, standards, CE • Notes for installation location • Application example, Standard application • Commissioning, operation and programming • Maintenance 	Installer
User manual	<ul style="list-style-type: none"> • Commissioning • Operation • User settings/programming • Fault table • Cleaning/maintenance • Energy-saving tips 	Customer
Asset ledger	<ul style="list-style-type: none"> • Commissioning report • Check list for commissioning • Maintenance 	Installer
Abridged instructions	<ul style="list-style-type: none"> • Operation in brief 	Customer
Accessories	<ul style="list-style-type: none"> • Installation • Operation 	Installer, customer

2.3 Symbols used

2.3.1 Symbols used in the manual

This manual uses various danger levels to draw attention to special instructions. We do this to improve user safety, to prevent problems and to guarantee correct operation of the appliance.



Danger

Risk of dangerous situations that may result in serious personal injury.



Danger of electric shock

Risk of electric shock.



Warning

Risk of dangerous situations that may result in minor personal injury.



Caution

Risk of material damage.



Important

Please note: important information.



See

Reference to other manuals or pages in this manual.

3 Technical specifications

3.1 Homologations

3.1.1 Regulations and standards

Beside the general technical rules, the relevant standards, regulations, ordinances and guidelines should be followed:

- DIN 4109: Sound insulation in buildings
- DIN EN 12828: Heating systems in buildings –, planning domestic hot water heating systems
- Federal Immission Control Ordinance 1. BImSchV
- DVGW-TRGI 1986 (DVGW-worksheet G 600): Technical Rules for gas installation
- TRF: Technical Rules LPG
- DVGW-Data sheet G - 613 Gas appliances- Installation, maintenance and operating instructions
- DIN 18380: Installation of central heating systems and hot water supply systems (VOB)
- DIN EN 12831: Heating systems in buildings -, Method for calculation of the design heat load
- DIN 4753: Domestic hot water calorifiers. Domestic hot water heating system and storage tanks for heated water
- DIN 1988: Technical rules for drinking water installations (TRW)
- DIN EN 60335-2-102: Safety of electrical appliances for household use and similar purposes: Special requirements for gas-, oil- und solid fuel appliances with electrical connections
- Fuel Ordinance, State Ordinances
- Regulations of the local Electricity Board
- Obligation to register (possibly. Group Exemption Regulation)
- ATV-Code-of-practice M251 of the waste water technology association
- Regulations of the public authorities for the run-off of condensate.

3.1.2 Manufacturer's Declaration

Meeting the protection requirements according to guideline 2014/30/EU for electromagnetic compatibility (EMC) is only guaranteed when the boiler is operated according to purpose.

The ambient conditions must be complied with as per EN 55014.

Operation is only allowed with the casing fitted correctly.

Correct electric earthing must be ensured by regular checks (e.g. annual inspection) of the boiler.

When appliance parts need replacing, only original parts as specified by the manufacturer may be used.

The gas condensing-boilers fulfil the basic requirements of the Efficiency Guideline 92/42/EC as condensing boiler.

When natural gas is used, the gas condensing-boiler emit less than $80 \text{ mg}_{\text{kWh}}$ NO_x corresponding to the requirements as per §6 of the Ordinance regarding small firing places dated 26.01.2010 (1. BImSchV).

3.2 Technical data

3.2.1 Technical data – Boiler space heaters in accordance with ErP guideline

Tab.2 Technical data – Boiler space heaters in accordance with ErP guideline

Product name			EC five 400 kW
Condensing boiler			Yes
Low-temperature boiler ⁽¹⁾			No
B1 boiler			No
Cogeneration space heater			No
Combination heater			No
Rated heat output	P_{rated}	kW	394
Useful heat output at rated heat output and high temperature mode ⁽²⁾	P_4	kW	393.8
Useful heat output at 30% of rated heat output and low temperature mode ⁽¹⁾	P_1	kW	130.5
Seasonal space heating energy efficiency	η_s	%	–
Useful efficiency at rated heat output and high temperature mode ⁽²⁾	η_4	%	88.3
Useful heat output at 30% of rated heat output and low temperature mode ⁽¹⁾	η_1	%	97.5
Auxiliary electricity consumption			
Full load	el_{max}	kW	0.463
Part load	el_{min}	kW	0.060
Standby mode	P_{SB}	kW	0.004
Other items			
Standby heat loss	P_{stby}	kW	0.300
Ignition burner power consumption	P_{ign}	kW	0.0
Annual energy consumption	Q_{HE}	GJ	–
Noise emission level	L_{WA}		
- room air-dependent		dB(A)	73
- room air-independent		dB(A)	67
Emissions of nitrogen oxides	NO_x	mg/kWh	< 56
(1) Low temperature mode means for condensing boilers 30 °C, for low temperature boilers 37 °C and for other heaters 50 °C return temperature (at heater inlet).			
(2) High temperature mode means 60°C return temperature at heater inlet and 80°C feed temperature at heater outlet.			



See
Contact details on the back cover.

3.2.2 Technical data

Tab.3 Technical data

Model	EC five 400 kW	EC five 470 kW	EC five 540 kW	EC five 610 kW		
Product ID no.	CE-0085 CL 0072					
Installation types	B ₂₃ , B _{23P} , C ₃₃ , C ₅₃ , C ₆₃ , C ₈₃ , C ₉₃					
Software version	V 4.6					
Power values						
Nominal heat input range	Heating	kW	82.0-402.0	95.0-469.0	109.0-539.0	122.0-610.0
Nominal heat output range	80/60°C	kW	80.4-393.8	93.0-459.0	106.6-526.9	119.2-595.7
	50/30°C	kW	88.9-426.0	102.8-496.6	117.7-570.3	131.5-644.8

Model			EC five 400 kW	EC five 470 kW	EC five 540 kW	EC five 610 kW
Standard utilisation (Hi/Hs)	75/60°C	%	106.4/95.4	106.1/95.1	106.2/95.2	106.3/95.3
	40/30°C	%	109.4/98.4	109.3/98.3	109.2/98.2	109.1/98.1
Gas and exhaust side values						
Gasvolume flow						
Natural gas E (G20) [H_{UB} 9,45 kWh/m ³]		m ³ /h	8,7 - 42,5	10,1 - 49,6	11,5 - 57,0	12,9 - 64,6
Natural gas LL (G25) [H_{UB} 8,13 kWh/m ³]		m ³ /h	9,8 - 47,9	11,3 - 55,9	13,0 - 64,2	14,5 - 72,7
Flue gas temperature	80/60°C	°C	57-64	58-61	58-64	57-64
Flue gas mass flow rate	80/60°C	kg/h	142.9-679.7	165.6-793.1	190.1-911.5	212.8-1031.4
Supply pressure						
Natural gas LL (G25)		mbar	min. 18 - max. 25			
Natural gas E (G20)		mbar	min. 17 - max. 25			
CO ₂ -content natural gas*						
Part load		%	8.7 - 9.0			
Full load		%	9.0 - 9.3			
NOx - concentration, weighted in accordance with EN 15502		mg/kWh	< 56			
NOx - class in accordance with EN 15502			6			
CO standard emission factor		mg/kWh	32	29	36	37
Max. delivery pressure at flue gas outlet		mbar	1.50			
Flue gas connection			DN 250			
Electrical connection values						
IP rating			IPX1D			
Electrical connection			230 V~ / 50Hz, max. 10.0 A			
Max. electr. power consumption						
Heating operation (full load, without pump)		W	463	583	790	750
Control (protection)		W	3.5			
Heating side values						
Max. water pressure			6.0 bar / 0.6 MPa			
Max. operating temperature (protection)		°C	110			
Max. flow temperature		°C	90			
Hydraulic resistance						
at $\Delta T=20^{\circ}\text{C}$		mbar	101	115	121	132
at $\Delta T=10^{\circ}\text{C}$		mbar	394	444	469	516
Other values						
Boiler weight		kg	540	598	636	674
Boiler water content		l	73	84	97	106
Height above everything		mm	1526			
Width		mm	762			
Depth		mm	1882	2192		
Noise emission level						
- room air-dependent		dB(A)	73	73	74	75
- room air-independent		dB(A)	67	67	68	68
(1) in case of fluctuating natural gas composition see section <i>CO₂-content</i>						

3.2.3 Technical data for the auxiliary contactor for the pump PHS

Rated current AC-3 380V 400V	A	7.0
Max. rated power three-phase motors 50- 50 Hz AC-3 380V 400V	kW	3.0

Permissible cable cross-sections		
solid wire	mm ²	1 x (0.75 - 4) 2 x (0.75 -2.5)
flexible cable with wire end ferrules	mm ²	1 x (0.75 - 2.5) 2 x (0.75 -2.5)

3.2.4 Tables of sensor values

Tab.4 Resistance values for outside temperature sensor ATF

Temperature [°C]	Resistance [Ω]
-20	8194
-15	6256
-10	4825
-5	3758
0	2954
5	2342
10	1872
15	1508
20	1224
25	1000
30	823

Tab.5 Resistance values for all other sensors

Temperature [°C]	Resistance [Ω]
0	32555
5	25339
10	19873
15	15699
20	12488
25	10000
30	8059
35	6535
40	5330
45	4372
50	3605
55	2989
60	2490
65	2084
70	1753
75	1481
80	1256
85	1070
90	915
95	786
100	677

3.2.5 Pressure drop secondary circuit

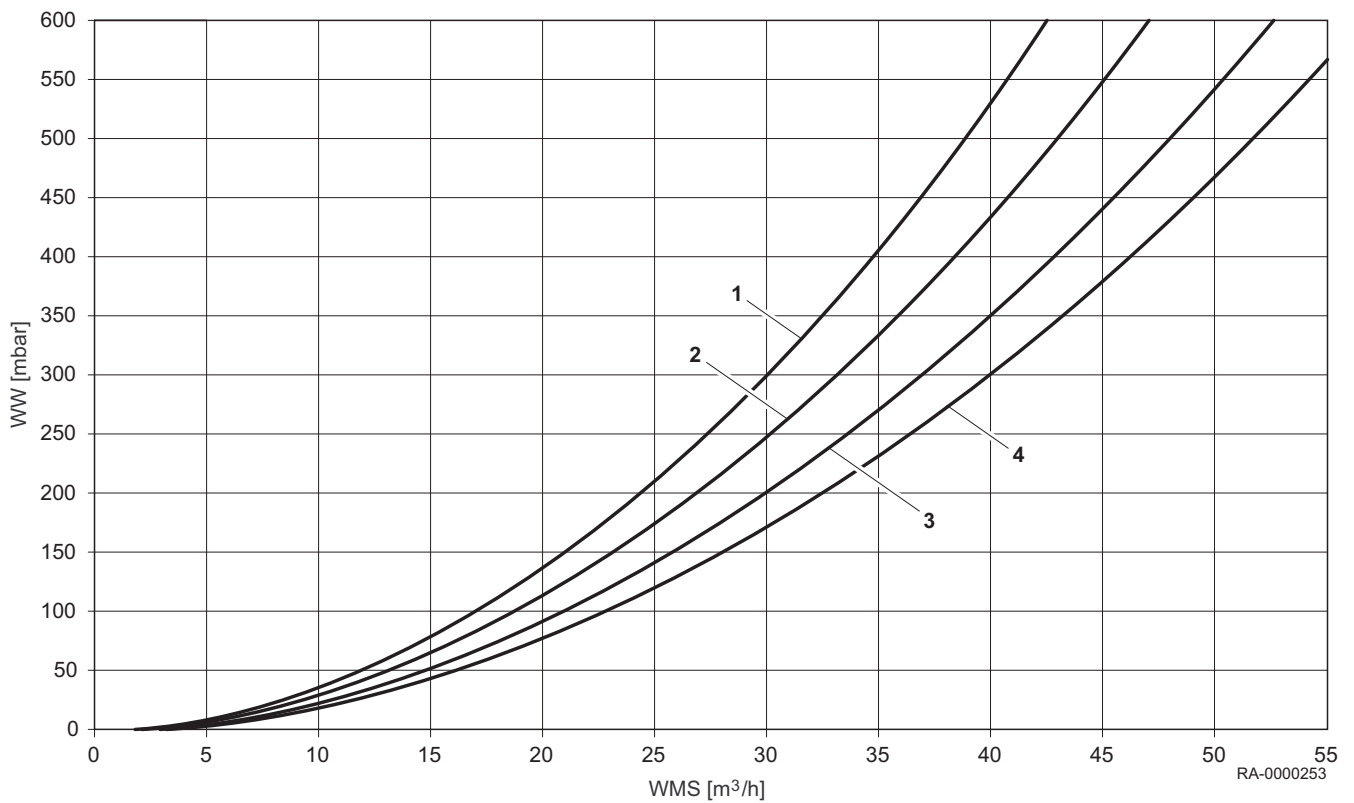

- WW** Pressure drop secondary circuit
WMS Water mass flow
1 EC five 400 kW
2 EC five 470 kW
3 EC five 540 kW
4 EC five 610 kW

3.2.6 Dimensions and connections

Fig.1 Dimensions and connections

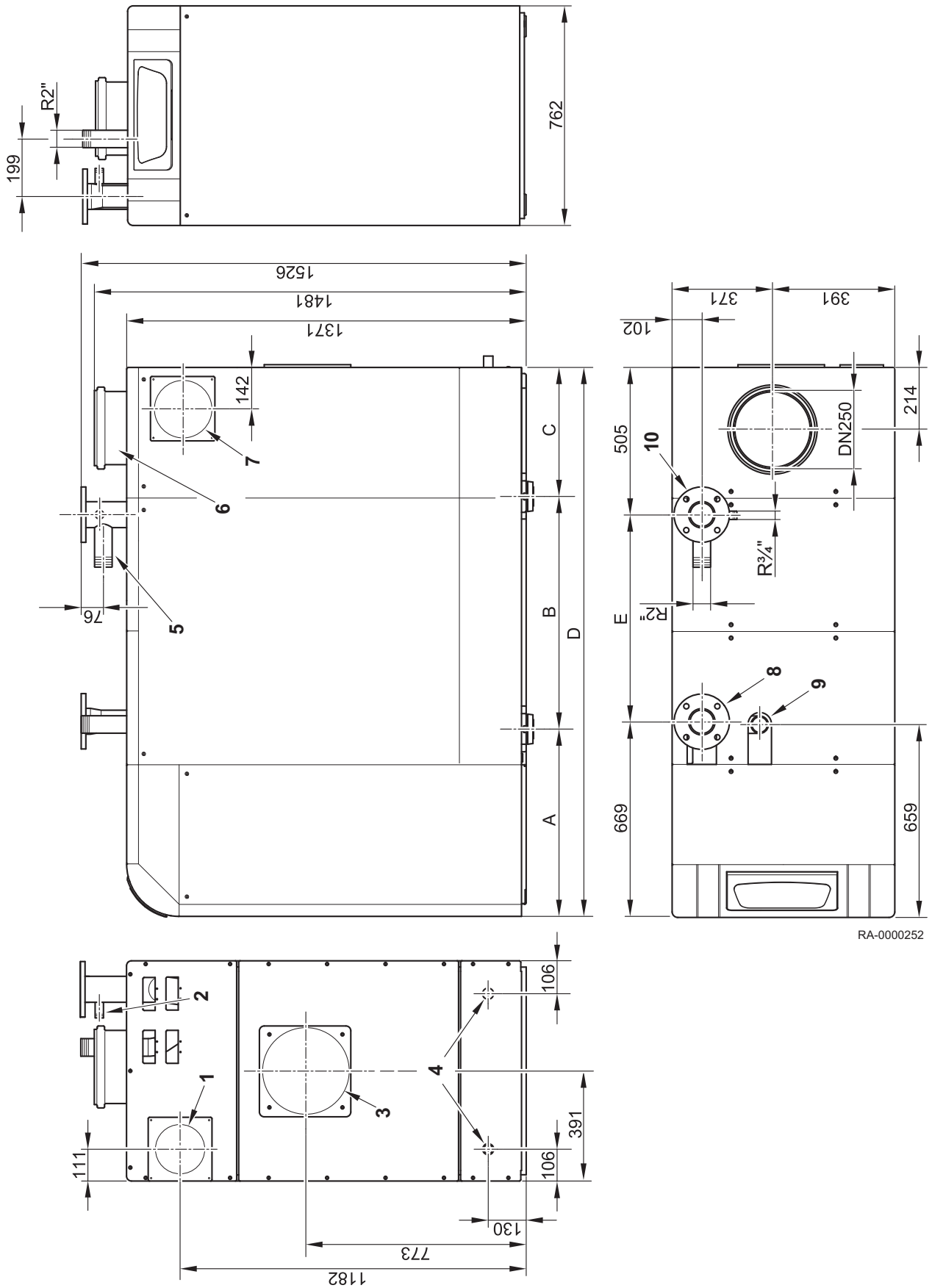

RA-0000208

RA-0000252

Tab.6 Dimensions

Model			EC five 400 kW	EC five 470 kW	EC five 540 kW	EC five 610 kW
1	Rear air supply duct (standard)		NW 160			
2	Safety group connection		AG R $\frac{3}{4}$ "			
3	Rear flue gas connection (optional)		DN 250			
4	Condensate connection(optional right/left)		DN 32			
5	Safety valve connection		AG R2"			
6	Top exhaust gas connection (standard)		DN 250			
7	Side air supply duct (optional)		NW 160			
8	Heating return (HR)		Flange DN 80 PN			
9	Gas connection		AG R2"			
10	Heating flow (HV)		Flange DN 80 PN			
Dimension A		mm	642	642	642	642
Dimension B		mm	798	1009	1009	1009
Dimension C		mm	442	540	540	540
Dimension D		mm	1882	2192	2192	2192
Dimension E		mm	709	1018	1018	1018

3.2.7 Wiring diagram

Fig.2 Wiring diagram

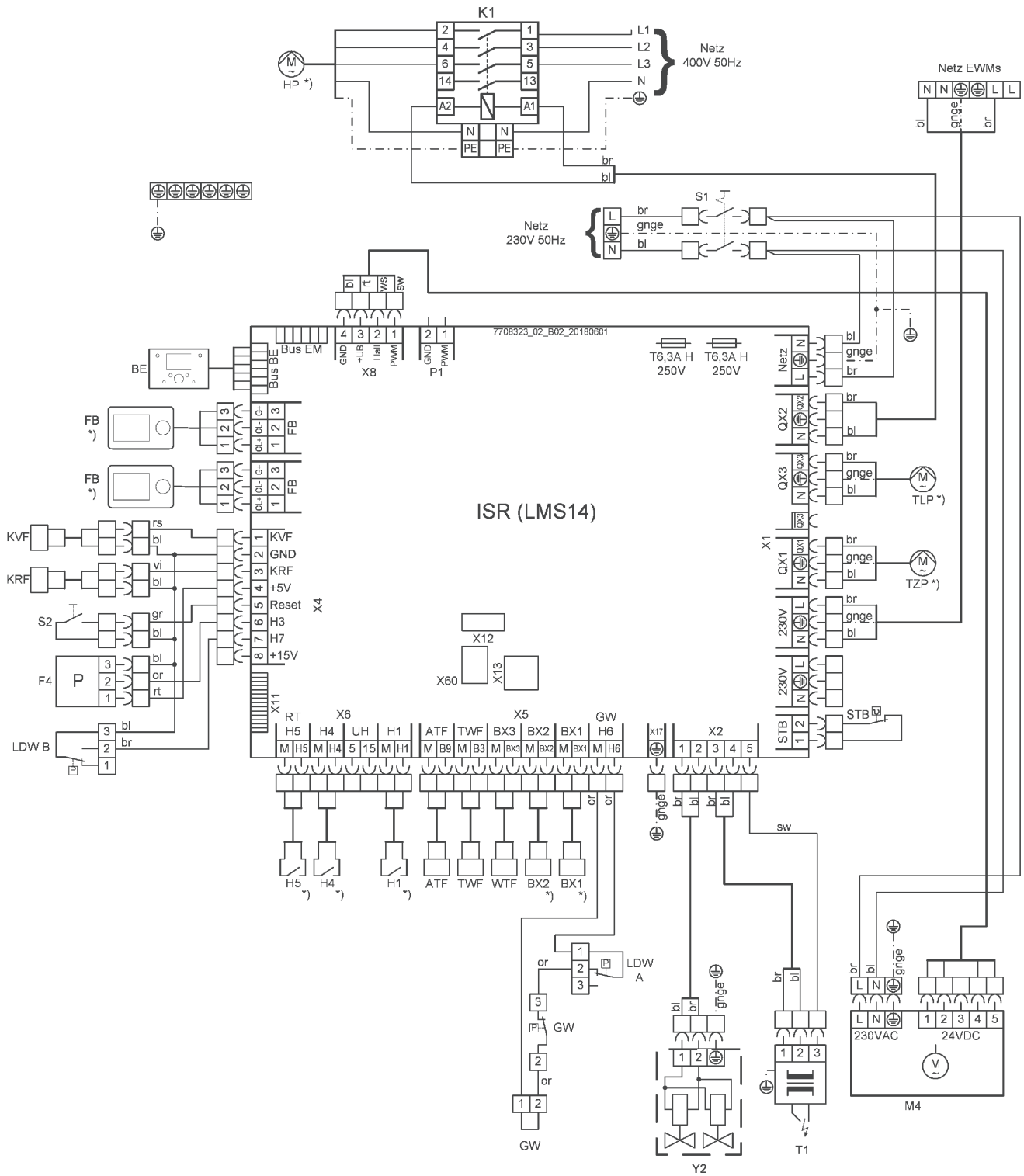

RA-0001346

- | | |
|---|--|
| ATF Outdoor temperature sensor QAC 34 | GW Gas pressure monitor |
| B1 Ionisation electrode | H1,4,5 Multifunctional Input *) |
| BE Operating unit | H6 Gas pressure Monitor input |
| Bus BE Bus connection for operating unit | HP Heating circuit pump *) |
| Bus EM Bus connection for expansion module | KRF Boiler return sensor type 36 |
| BX1...3 Multi-function sensor input | KVF Boiler flow sensor type 36 |
| F4 Water pressure sensor | K1 Auxiliary contactor for the pump |
| FB Remote control *) | LDW A Air pressure monitor flue gas |

LDW B Air pressure monitor blanking plate
M4 Burner fan
Netz Mains Connection 230V/50Hz
P1 PWM output
QX1...3 Multifunctional output
S1 ON/OFF switch
S2 Unlocking
STB Safety temperature limiter
T1 Ignition transformer

rs pink
rt red
vi purple
gr green
bl blue

TLP Domestic water charging pump *)
TWF DHW sensor type 36
TZP Domestic water circulation pump *)
WTF Heat exchanger sensor
X11,60 Bus module interface
X12,13 Service interfaces
Y2 Gas solenoid valve
***)** Accessories

sw black
or orange
br brown
gnge green/yellow

4 Description of the product

4.1 Operating principle

Fig.3 Description of function of the air pressure monitor (schematic drawing)

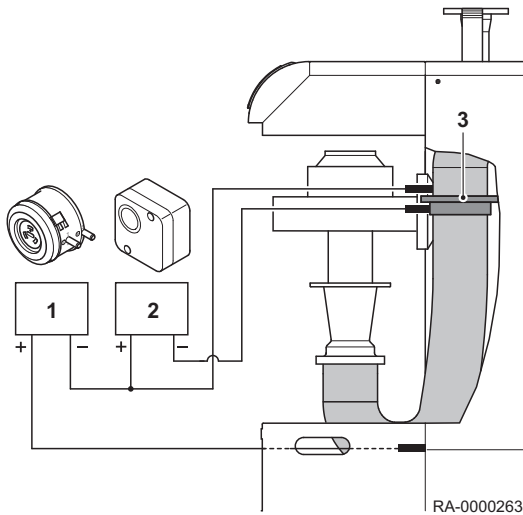

4.1.1 Description of the function of the air pressure monitor

- 1 Air pressure monitor flue gas
- 2 Air pressure monitor blanking plate
- 3 Blanking plate

In boiler operation the flue gas air pressure monitor monitors the differential pressure between the condensate bowl and the blanking plate. If this differential pressure exceeds a value of 6 mbar, the burner is shut off and the error message "132" is displayed.

Causes:

- blocked siphon
- blocked flue gas pipe
- blocked air filter
- blocked suction pipe

After the burner shuts off this differential pressure is no longer present and the error message "132" disappears. The burner restarts. During pre-venting pressure switch 2 is queried. If the differential pressure set on the blanking plate air pressure monitor is not reached via the blanking plate, a fault switch-off occurs (error message "162 air pressure monitor") and the boiler is locked.



For more information, see
Fault code table, page 150

4.1.2 Circulating pump



Important

The benchmark for the most efficient circulating pumps is $EEL \leq 0.20$.

4.2 Main components

4.2.1 Boiler

Fig.4 EC five 400 kW-540 kW

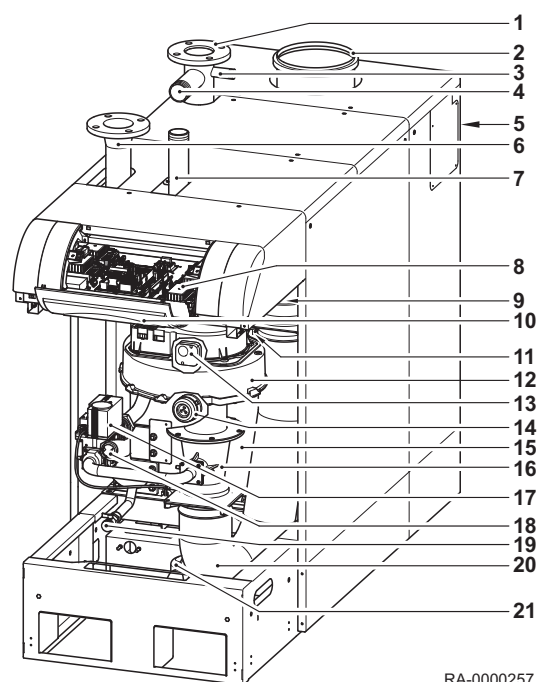

- 1 Boiler flow
- 2 Flue gas connection
- 3 Connection for safety group
- 4 Connection for safety valve
- 5 Air supply duct
- 6 Boiler return
- 7 Gas connection
- 8 Boiler control LMS
- 9 Ignition transformer (below the control housing)
- 10 Control damper
- 11 Ignition and ionization electrode/flame inspection window
- 12 Fan
- 13 Air pressure monitor blanking plate (behind the fan)
- 14 Air pressure monitor flue gas (behind the fan)
- 15 Heat exchanger
- 16 Venturi
- 17 Gas valve (Honeywell)
- 18 Water pressure monitor (on boiler return)
- 19 Filling/emptying (BFD valve)
- 20 Suction hose
- 21 Siphon

Fig.5 EC five 610 kW

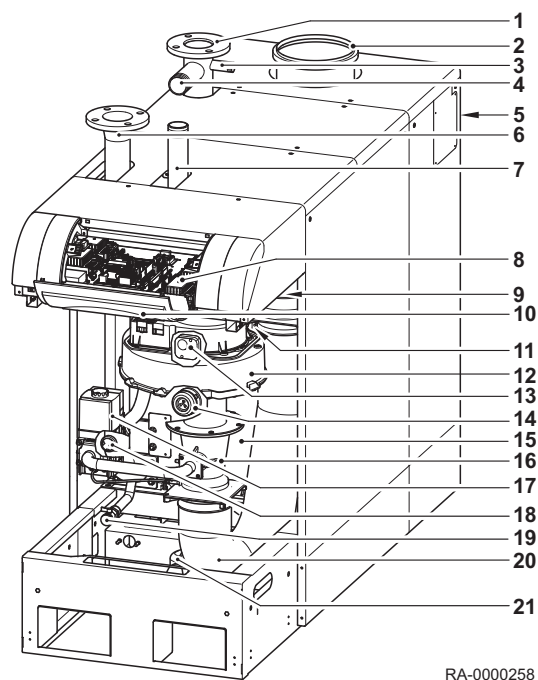

- 1 Boiler flow
- 2 Flue gas connection
- 3 Connection for safety group
- 4 Connection for safety valve
- 5 Air supply duct
- 6 Boiler return
- 7 Gas connection
- 8 Boiler control LMS
- 9 Ignition transformer (below the control housing)
- 10 Control damper
- 11 Ignition and ionization electrode/flame inspection window
- 12 Fan
- 13 Air pressure monitor blanking plate (behind the fan)
- 14 Air pressure monitor flue gas (behind the fan)
- 15 Heat exchanger
- 16 Venturi
- 17 Gas valve (Dungs)
- 18 Water pressure monitor (on boiler return)
- 19 Filling/emptying (BFD valve)
- 20 Suction hose
- 21 Siphon

4.3 Control panel description

Fig.6 Operating elements

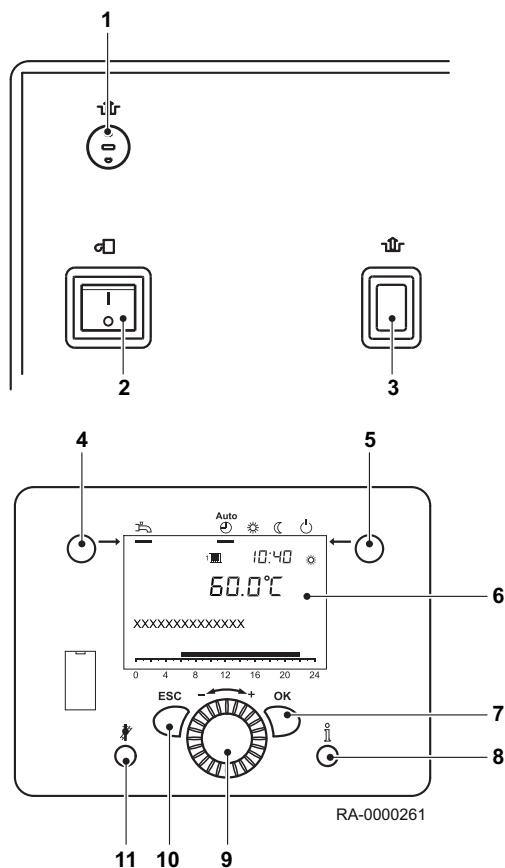

4.3.1 Operating elements

- 1 Reset safety temperature limiter (STB)
- 2 ON/OFF switch
- 3 Reset button burner control
- 4 Operating mode key, domestic water mode
- 5 Operating mode key, heating mode
- 6 Screen
- 7 OK key (acknowledgement)
- 8 Information key
- 9 Control knob
- 10 ESC key (cancel)
- 11 Chimney sweep key

4.3.2 Displays

Fig.7 Symbols on the display

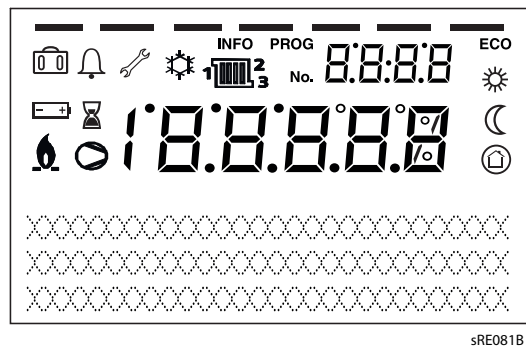

- Heating to comfort setpoint
- Heating to reduced setpoint
- Heating to frost protection setpoint
- Current process
- Holiday function active
- Reference to heating circuits
- Burner in operation (boiler only)
- Cooling active (heat pump only)
- Compressor in operation (heat pump only)
- Maintenance message
- Fault message
- INFO** Information level active
- PROG** Setting level active
- ECO** Heating system switched off (automatic summer/winter changeover or automatic heating limit active)

4.4 Accessories and options

4.4.1 Room device RGP

Remote setting of all adjustable control functions of the basic appliance is possible via the operating unit when using the room device RGP (accessory).

■ Operating elements

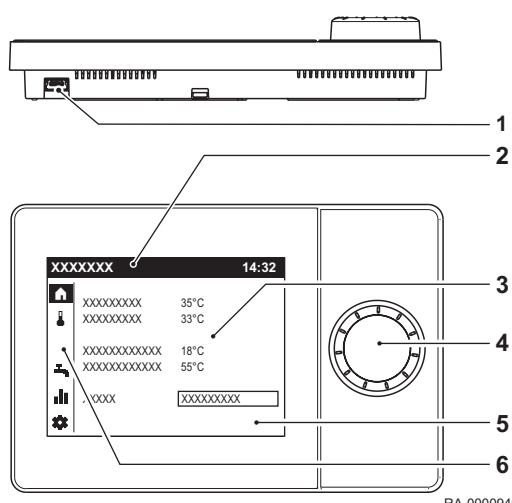

RA-0000940

- 1 USB connection for service tool
- 2 Status bar
- 3 Work area
- 4 Control knob
- 5 Display
- 6 Navigation bar

The control knob is used to operate the room unit.

The display is organized into a navigation bar, status bar, and work area.



Important

The current room temperature is displayed in standby.

4.4.2 Installation of extension modules

More application options are available by installing up to 3 extension modules (accessories) of the series EWM B or MEWM (e.g. mixer heating circuit, solar connection, actuation of speed controlled pumps with MEWM).



See

More information about the extension module EWM can be found in the *Installation instructions extension module EWM*.

5 Before installation

5.1 Regulations governing installation



Caution

Installation of the appliance must be done by a qualified engineer in accordance with prevailing local and national regulations.

5.2 Corrosion protection



Caution

When connecting heat generators to under-floor heating systems employing plastic pipes which are not impervious to oxygen in accordance to DIN 4726, heat exchangers must be used for separation purposes.



Important

Prevention of damage in hot water heating systems caused by corrosion on the water side or scaling.

5.3 Supply air openings



Caution

Keep the inflow area clear.

Never block or close off ventilation apertures. The inflow area for combustion air must be kept clear.



Warning

Risk of damage!

The condensing boiler may only be installed in rooms with clean combustion air. Foreign matter such as pollen must never filter through the inlet apertures to reach the inside of the appliance. The boiler must not be started up if there is heavy dust development e.g. during construction work. There could be damage to the boiler.

For ventilation-based operation of the EC five, an adequately sized opening for combustion air must be present in the place of installation. The operator must be informed that this opening must never be closed or blocked and that the connecting piece for combustion air on the upper side of the EC five must be kept free at all times.

5.4 Treating and preparing the heating water

5.4.1 Introduction

This section explains the conditions for heating water when Potterton condensing boilers are used.



Important

Please note that the boiler EC five has an **aluminium silicon heat exchanger**.

5.4.2 Protecting the heat generator

Faults in the heating circuit caused by corrosion or limescale deposits reduce the efficiency and functionality of the heat generator.

The quality of the fill water must meet specific requirements. You should therefore take preventive measures in certain cases.

- For systems with underfloor heating and piping which is permeable to oxygen, system separation must be used between the heat generator and other system parts which are at risk of corrosion.
- Heating systems in which a Potterton condensing boiler is to be installed must be designed as a closed heating system with diaphragm expansion vessel in accordance with DIN EN 12828.
- Directly connecting a Potterton heat generator to an "open" heating system is not permitted. System separation must also be used here. In "open" systems, the connection to the outdoor air causes oxygen to be absorbed in such a quantity that it leads to corrosion in the heating system. Furthermore, the objective of consistent energy savings is not achieved due to the additional heat loss via the "open" expansion vessel. Gravity systems with an "open" expansion vessel are not in line with current technology.

5.5 Heating water requirements



Caution

Note the requirement for the heating water quality.

Requirements regarding heating water quality have increased in recent times as system conditions have changed:

- Reduced heat demand.
- Use of cascades in larger buildings.
- Increased use of buffer cylinders in combination with solar thermal energy and solid fuel boilers.
- Power-generating heating systems.
- Storage tank charging systems and similar.

The focus is always on designing systems that are guaranteed to operate reliably throughout their service life without any faults.

The following requirements apply to the heating water quality in the entire circuit, based on VDI directive 2035 Sheets 1 and 2. In the case of renovation measures, it is not sufficient to merely fill partial sections according to VDI 2035.

- The pH of the heating water must be between 8.2 and 9.0 during operation. A corrosion inhibitor can be added to the heating water. The manufacturer specifications must be complied with.
- The water must not contain any foreign substances, such as beads of sweat, rust particles, scale, sludge or other sedimenting substances. During commissioning, flush the system until only clean water runs out. When flushing the system, ensure that water does not flow through the heat exchanger in the heat generator, that the radiator thermostats are removed and that the valve inserts are set to the maximum flow rate.

Generally speaking, the quality of drinking water is adequate, but a check must be performed to ensure that the drinking water available in the system is suitable for filling the system in terms of its hardness and water constituents (see *water hardness diagram*). If this is not the case, various measures are possible.

**Caution**

Warranty claims are excluded if the specified measures or required values are not adhered to or if documentation is missing.

5.5.1 Addition of a product to treat the heating water

**Caution**

Use only approved products or methods which have the following properties:

- **Hardness stabilisers** prevent the precipitation of hardness.
- **Cleaning products** dissolve dirt in the circuit and may also keep the dissolved dirt suspended.
- **Corrosion protection products** form a protective layer on metallic surfaces.
- **Full protection products** prevent the precipitation of hardness, have a cleaning effect, keep the dissolved dirt in suspension (dispersion) and form a corrosion protection layer on metallic surfaces.

Only products approved by Potterton may be used to treat heating water. Softening/desalination may only be carried out using appliances approved by Potterton, while taking the limit values into consideration.

**Caution**

If non-approved agents are used, no warranty rights or guarantees are valid.

The following products are currently approved by Potterton:

- "Full heating protection" from Fernox (www.fernox.com)
- „Sentinel X100“ from Sentinel (www.sentinelprotects.com)

If **products** are used, the manufacturer specifications must be observed. If it is necessary to use additives as part of a mixture in special cases, e.g. hardness stabiliser, antifreeze agent, sealant, etc., you must ensure that the agents are compatible with each other and that the required pH in the circuit continues to be adhered to. Preferably, agents from the same manufacturer should be used.

- Ensure that the electrical conductivity of the fill water corresponds to the manufacturer specifications for the relevant dosing rate, with the addition of an inhibitor.
- The electrical conductivity in the circuit must not rise significantly (+ 100 $\mu\text{S}/\text{cm}$), even after a prolonged running time, without the dose having been increased.
- The pH of the circuit water must be between 8.2 and 9.0 during operation.
- The pH, electrical conductivity and product content of the heating water must be checked after eight weeks of operation and then once per year.
- The measured values must be documented in the service book.

5.5.2 Softening/partial softening

Use of a softening system to treat the fill water and to prevent damage caused by the formation of scale in the boiler.

- Partially softened fill water according to the table from VDI 2035 Sheet 1 can generally be used.
- VDI 2035 Sheet 2 must be observed.
- The pH of the circuit water must be between 8.2 and 9.0 during operation.
- Automatic alkalinisation of the system water (pH increase caused by carbon dioxide outgassing) begins under various conditions.
- The pH, electrical conductivity and $^{\circ}\text{dH}$ of the circuit water must be checked after eight weeks of operation and then once per year.
- Document the measured values in the service book.

**Important**

A softening system reduces calcium and magnesium to prevent the formation of scale (VDI directive 2035 Sheet 1). No corrosive water components are reduced or removed (VDI directive 2035 Sheet 2).

Tab.7 Table to VDI 2035 Sheet 1

Total heating output in kW	Total hardness in °dH depending on the specific system volume		
	< 20 l/kW	≤ 20 l/kW and < 50 l/kW	≥ 50 l/kW
< 50 ⁽¹⁾	≤ 16.8	≤ 11.2	< 0.11
50 - 200	≤ 11.2	≤ 8.4	< 0.11
200 - 600	≤ 8.4	< 0.11	< 0.11
> 600	< 0.11	< 0.11	< 0.11

(1) for circulation water heaters (< 0.3 l/kW) and systems with electric heating elements

5.5.3 Full desalination/partial desalination

Use of a desalination system to treat the fill water.

- Fully desalinated water or partially desalinated water can generally be used for filling.
- The electrical conductivity of desalinated additional water must not exceed 15 µS/cm for full desalination and 180 µS/cm for partial desalination.
- The electrical conductivity in the circuit must not exceed 50 µS/cm with full desalination and 370 µS/cm with partial desalination during filling.
- The pH of the circuit water must be between 8.2 and 9.0 during operation.
- The pH, electrical conductivity and product content of the heating water must be checked after eight weeks of operation and then once per year.
- Desalination of fill and top-up water to obtain fully desalinated water should not be mistaken for softening down to 0 °dH. Water softening does not remove corrosive salts.

5.5.4 Maintenance



Caution

The quality of the circuit water must be checked and documented as part of annual system maintenance. Depending on the measurement result, the necessary measures must be taken in order to re-establish the required values for the circuit water. Furthermore, the cause of the changes must be established and permanently corrected in the event of severe deviations. Warranty claims are excluded if the specified values are not adhered to or if documentation is missing.

5.6 Determining the system volume

Fig.8 Determining the system volume

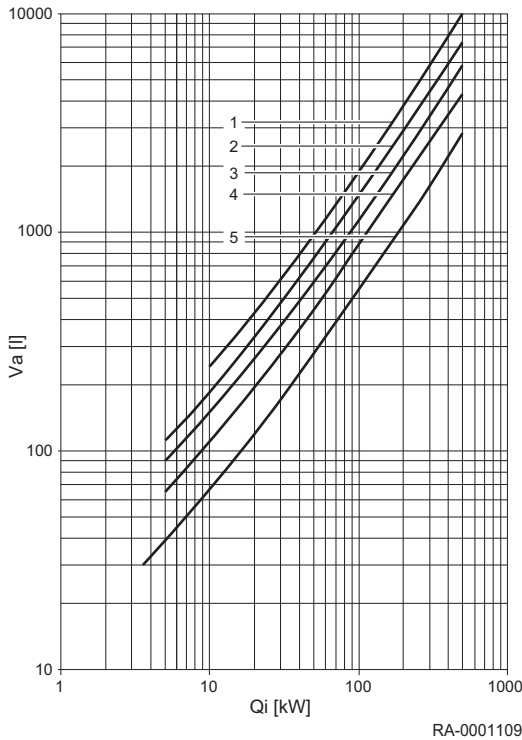

- Qi Rated system output
- Va Average total water content
- 1 Underfloor heating
- 2 Steel radiators
- 3 Cast iron radiators
- 4 Steel panel radiators
- 5 Convectors

The total water volume in the heating system is calculated using the system volume (= fill water volume) plus the top-up water volume. In the Potterton boiler-specific diagrams only the system volume is given to make them easier to read. Over the entire service life of the boiler, a maximum top-up volume of twice the system volume is assumed.

5.7 Practical information for qualified heating specialists

- If an appliance is replaced in an existing system, we recommend installing a sludge separator, e.g. WAM C SMART (accessory) in the system return, upstream of the heat generator. Potterton recommends using the AguaClean filtration module to achieve an optimum cleaning result, including magnetite deposits.
- Document the filling (VDI directive 2035 Sheet 2 Section 4 "Principles"). The **Potterton service book** must be used for this.
- To prevent gas pockets and gas bubbles, it is essential to fully vent the heat generator at maximum operating temperature.
- Offer maintenance contracts for all the equipment in the system.
- Check proper operation with regard to pressure maintenance on an annual basis.
- Potterton recommends using of approved systems for initial filling, for replacing water and for top-ups.

5.8 Use of antifreeze agents with Potterton heat generators



Important

The use of antifreeze agents with Potterton gas-fired condensing boilers with aluminium heat exchangers.

The heat transfer fluid WTF B (accessory) offered for solar thermal systems is also used in heating systems (e.g. holiday homes) as an antifreeze agent. The freezing point ("crystallization point") of the ready mixed heat transfer fluid is -24 °C and the maximum frost protection ("setting point") is -32 °C. As it has a lower heat capacity than pure water but is more viscous, boiling noises may occur under unfavourable system conditions.

Frost protection down to -32 °C is not required for most heating systems; -15 °C is usually sufficient. The heat transfer fluid must be diluted 2:1 with water to set this operating point. This mixing ratio has been tested by Potterton in relation to its practical suitability for use with condensing boilers.



Important

Up to a mixing ratio of 2:1, the heat transfer fluid WTF B is approved as frost protection down to -15 °C for use with Potterton condensing boilers.



Caution

Keep the installation room frost-free.

If an antifreeze agent is used, pipework, radiators and condensing boilers are protected against frost damage. For the condensing boiler to be ready for operation at any time, suitable measures must also be taken to keep the installation room frost-free. If applicable, please also note special measures for any installed domestic hot water calorifiers.

The table shows the relevant volumes of heat transfer fluid and water that need to be mixed together for varying volumes of water. If other frost protection temperatures are required in exceptional cases, individual calculations can be made on the basis of this table.

Water content of the system [l]	Volume WTF B [l]	Mixing in water ⁽¹⁾ [l]	Frost protection down to [°C]
50	36	14	-15
100	71	29	-15
150	107	43	-15
200	143	57	-15
250	178	72	-15
300	214	86	-15
500	357	143	-15
1000	714	286	-15

(1) The water for the mixture must be neutral (drinking water quality with no more than 100 mg/kg chlorine) or demineralised. Please also follow the manufacturer instructions.

5.9 Choice of the location

5.9.1 Notes for installation location



Caution

Install the boiler on a solid, stable structure able to bear its weight.



Caution

Danger of damage from water!

The following must be observed when installing the EC five: In order to prevent damage due to water, particularly due to leakages in the DHW storage tank, suitable precautionary measures should be taken regarding installation.

Installation room

- The installation room must be dry and frost-free.
- The installation location has to be selected particularly with respect to the routing of the flue gas pipes. When installing the boiler, the specified wall clearances have to be maintained.
- Along with the general rules of the technology, especially the regulations of the federal German states, such as fire and construction ordinances as well as heating room guidelines, must be observed. There should be sufficient space in front of the equipment to carry out inspection and maintenance work.



Caution

Danger of damaging the device!

Aggressive foreign substances in the combustion supply air can destroy or damage the heat generator. Therefore the installation in rooms with heavy dust accumulation is only allowed with room air independent operating modes.

If the EC five is operated in rooms in which solvents, cleaning agents containing chlorine, paints, glues or similar substances are worked with or in which such substances are stored, only room air independent operation is permissible. This applies especially for rooms in which ammonia and its compounds, nitrites and sulphides are present (animal breeding and recycling facilities, battery and galvanising rooms, etc.).

During the installation of the EC five under these conditions DIN 50929 (Corrosion probability of metallic materials with external corrosion loading) as well as information sheet i. 158; "German Copper Institute" is heeded.

For damages occurring due to the installation in an unsuitable location or based on improper combustion air supply, there is no warranty claim.

5.9.2 Combustion air openings

Openings for the combustion air must be provided in the installation room of the gas condensing boiler.

■ Room air-dependent operation

The required cross-sections for the combustion air openings with room air-dependent operation are to be taken from the following table:

Model	Cross-section of the combustion opening [cm ²]
EC five 400 kW	> 850
EC five 470 kW	> 990
EC five 540 kW	> 1130
EC five 610 kW	> 1270

■ Room air-independent operation

For room air-independent operation an upper and a lower combustion air opening with a cross-section of at least 150 cm² is necessary.

Danger
Risk of life due to escaping flue gas! The combustion air openings must not be covered by any objects placed in front of them. Otherwise it could possibly lead to poisoning due to escaping flue gas. In addition damage to the boiler could occur.

5.9.3 Space requirement

Fig.9 Recommended space requirement

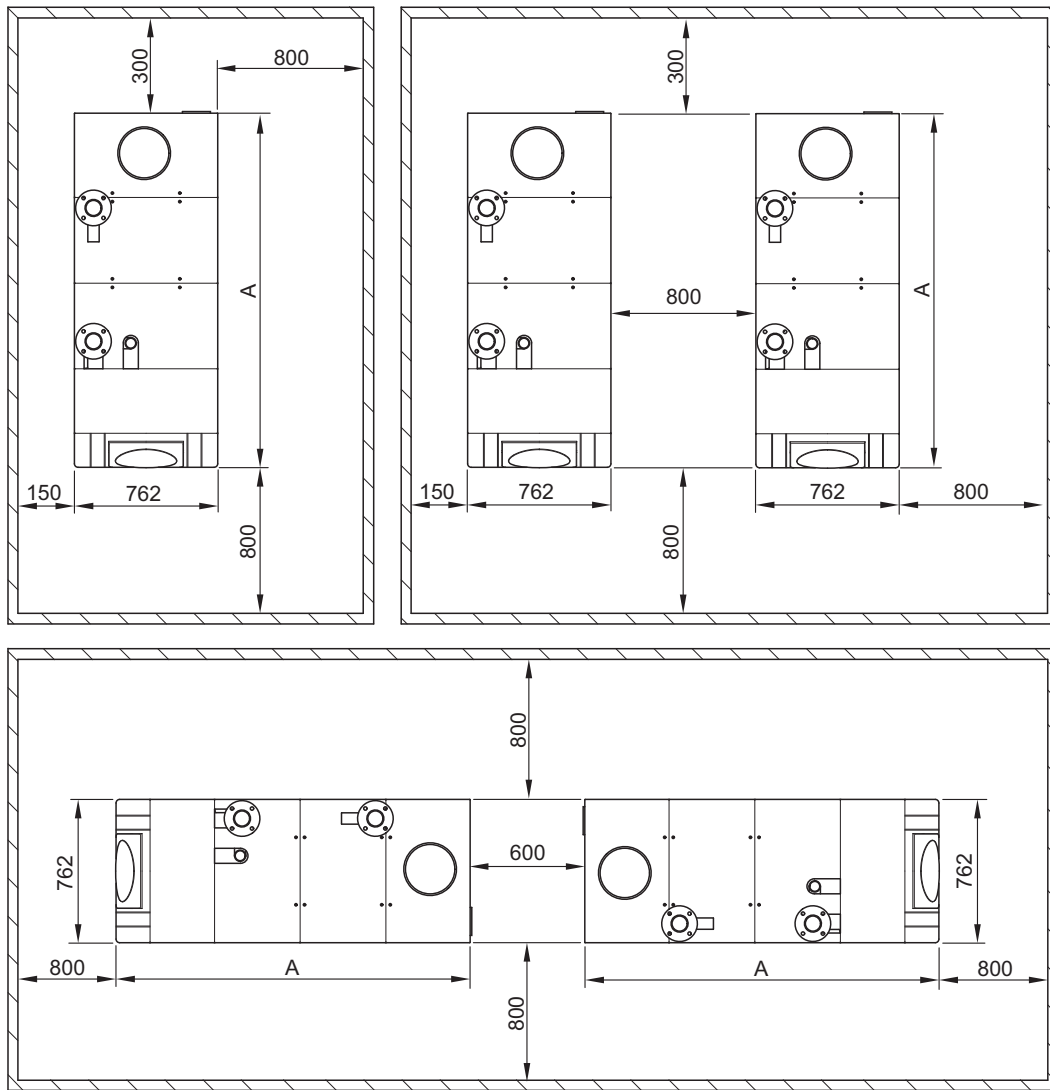

RA-000265

		EC five 400 kW	EC five 470 kW	EC five 540 kW	EC five 610 kW
Dimension A	mm	1882	2192	2192	2192

5.10 Transport

5.10.1 General



Danger

Some components, e.g. the preinstalled components or certain spare parts, exceed the recommended maximum lifting capacity for individual people that is recommended by employment law.

Risk of personal injury caused by heavy loads.

- Do not work alone.
- Use the lifting aids.
- Secure the unit during transport.
- Do not place any other objects on the unit.



Danger

Risk of injury due to the unit tipping over!

- When using transport aids, ensure that the weight is distributed evenly.



Caution

Risk of damage to the unit caused by impact during transport.

- The unit must be protected against heavy impacts during transport.



Notice

You must ensure that any stairs and doors have sufficient passage width before transporting the unit.



Caution

During transport, only lift the unit onto load-bearing panels or the parts provided for this purpose for transport.



Notice

Always transport the boiler as close to the installation site as possible before the packaging is removed.

5.10.2 Unpacking



Caution

Sharp-edged packaging material

Risk of cuts on the sharp-edged cardboard packaging

- Wear gloves when unpacking the CHP system.



Danger

Risk of asphyxiation!

The unit's packaging material (e.g. plastic film) presents a risk of asphyxiation for children.

- Never allow children to play with packaging material.



Important

Dispose of packaging material correctly.

5.10.3 Moving by crane



Danger

Risk to life due to boiler falling!

Crane work may only be carried out by trained specialists.

The straps or support cables to be used for lifting must be checked for perfect condition before use.

Persons involved in transport must wear protective gloves and safety footwear.



Caution

Risk of damage to boiler by impacts during transport!

The boiler must be protected against impact during transport.

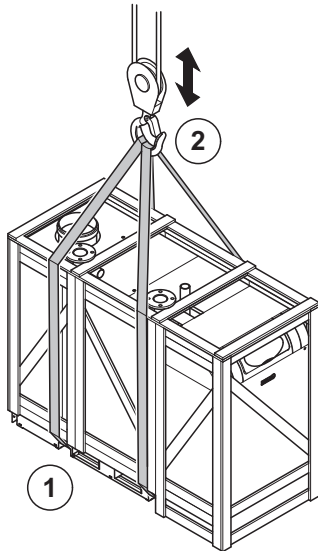

RA-0000266

1. Place the carrying straps or support cables around the wood cladding of the boiler as shown in the illustration
2. Lift the boiler by crane and set it down at the installation location
3. Remove the crane hook
4. Remove the carrying straps or support cables

5.10.4 Moving by one pallet truck



Danger

Risk to life due to boiler tipping!

When using pallet trucks make sure the weight is distributed evenly on the forks.

Persons involved in transport must wear protective gloves and safety footwear.



Caution

Risk of damage to boiler by impacts during transport!

The boiler must be protected against impact during transport. In addition avoid pulling or pushing forces on the gas pipes or the fan.

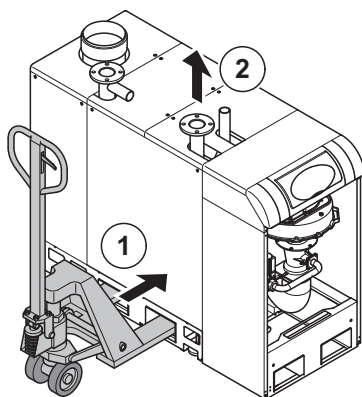

RA-0000267

1. Push the pallet truck forks through the transport openings on the side of the boiler.
2. Slowly lift the boiler
3. Move the boiler to the installation location and set it down
4. Remove the pallet truck

5.10.5 Moving by two pallet trucks



Danger

Risk to life due to boiler tipping!

When using pallet trucks make sure the weight is distributed evenly on the forks.

Persons involved in transport must wear protective gloves and safety footwear.



Caution

Risk of damage to boiler by impacts during transport!

The boiler must be protected against impact during transport. In addition avoid pulling or pushing forces on the gas pipes or the fan.

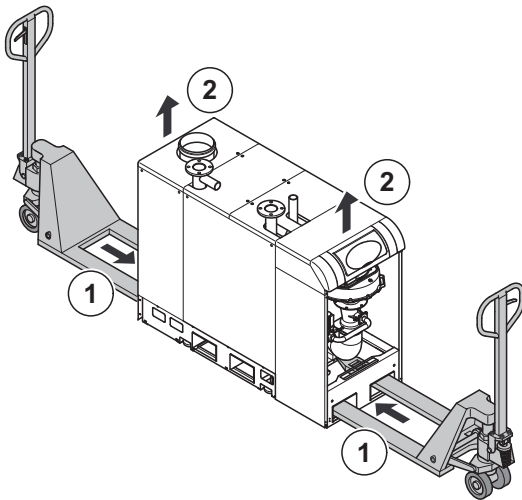

RA-0000268

1. Push the pallet truck forks through each of the rear and front transport openings of the boiler.
2. Lift the boiler slowly and evenly using both pallet trucks
3. Move the boiler to the installation location and set it down
4. Remove both pallet trucks

5.10.6 Transport on rollers



Caution

Risk of damage to boiler by impacts during transport!

The boiler must be protected against impact during transport. In addition avoid pulling or pushing forces on the gas pipes or the fan.



Important

The use of rollers for transporting the boiler is only possible on completely even floors. Pieces of steel pipe with a width of approx. 1000 mm and a diameter of approx. 30 mm can be used as rollers.

1. Place the pieces of pipe on the floor spaced at approx. 300 mm.
2. Lift the boiler onto the pipe pieces using a crane or pallet truck.
3. Move the boiler on the rollers to the installation room

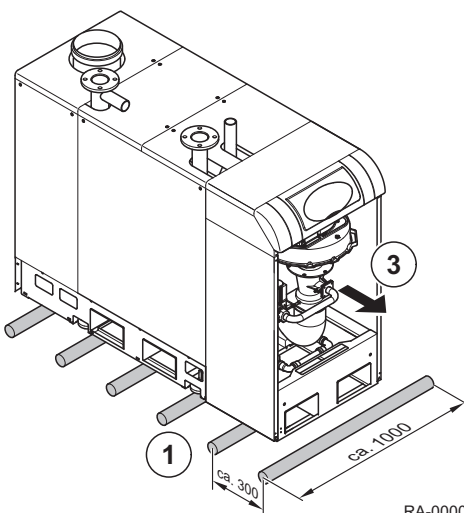

RA-0000269

5.10.7 Moving the boiler in tight spaces

When the boiler has to be moved into a tight space it can be helpful to remove the front frame, the fan and the venturi tube with integrated gas valve. This makes the boiler shorter and allows it to be manoeuvred around tight bends more easily.

1. Remove front cladding and front side cladding
2. Lift the control box upwards and keep hold of it
3. Secure the control box with a lock
4. Remove all connection plugs on the top of the fan

Fig.10 Lifting the control box upwards

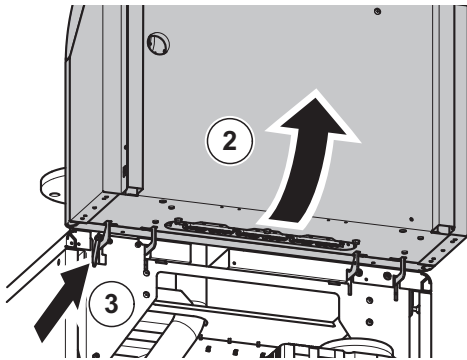

RA-0000270

Fig.11 Loosening the screwed connections

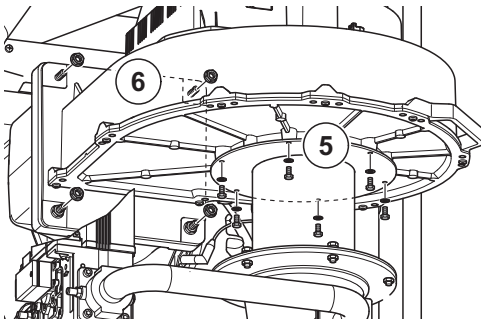

RA-0000271

5. Loosen the screws on the connection piece to the venturi tube on the bottom of the fan
6. Remove connection screws to the mixing adapter

Fig.12 Removing the fan

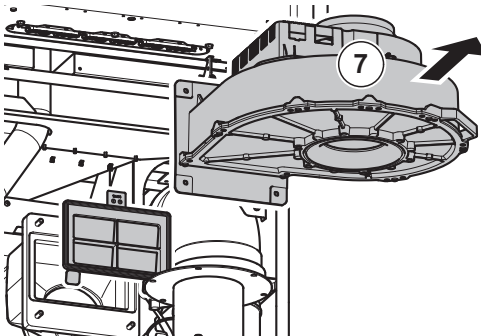

RA-0000272

7. Remove fan with air flap

Fig.13 Removing the front frame

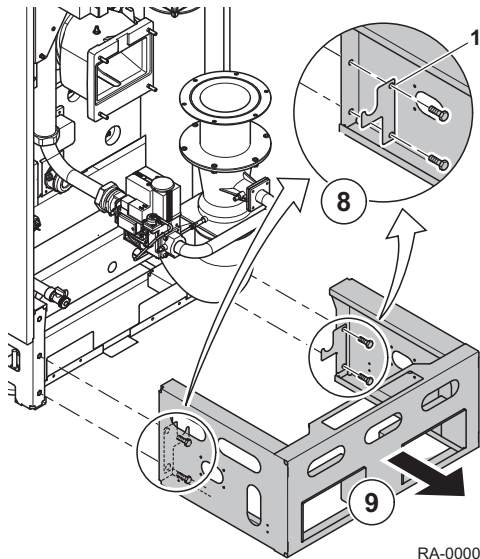

RA-0000273

8. Loosen the screws on the front frame

1 Support bracket condensate piping

i Important
The support brackets for the condensate piping must be installed when reinstalling the front frame.

9. Remove the front frame

Fig.14 Loosening the screwed connections

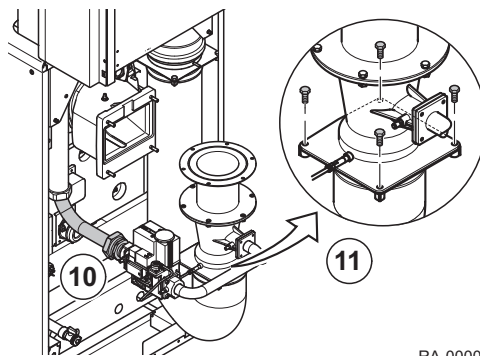

RA-0000274

10. Disconnect the gas supply line on the gas valve

11. Loosen the hexagon head screws on the lower venturi tube flange

Fig.15 Removing the venturi tube with gas valve

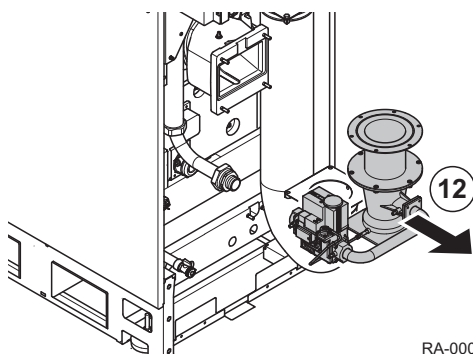

RA-0000275

12. Remove the venturi tube with integrated gas valve

13. Reinstall the venturi tube with integrated gas valve, fan and front frame in the reverse sequence after setting the boiler in place.

Fig.16 Dimensions without frame, fan and venturi tube

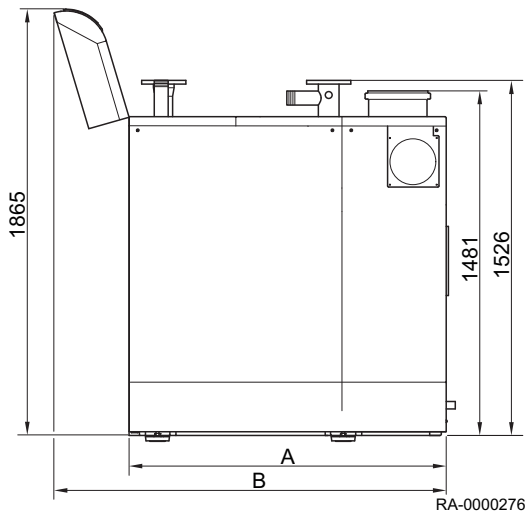

Model		EC five 400 kW	EC five 470 kW	EC five 540 kW	EC five 610 kW
Dimension A	mm	1360	1670	1670	1670
Dimension B	mm	1680	1990	1990	1990
Weight	kg	540	598	636	674

5.11 Connecting diagrams

5.11.1 Application examples

Fig.17 EC five, one mixer heating circuit and hot water preparation, AguaSave and AguaClean optional (hydraulic diagram)

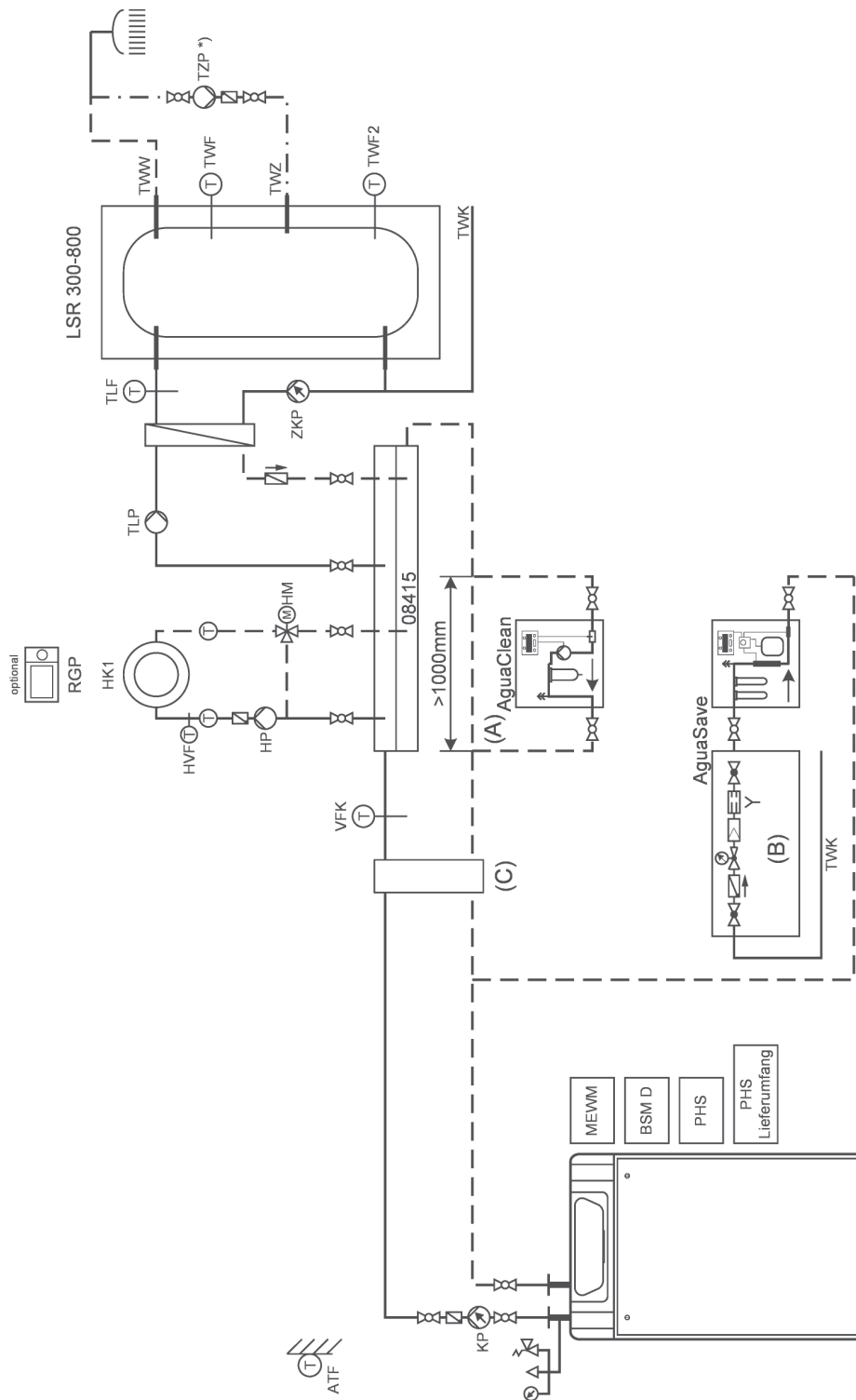

RA-08415-B01

Cold water connection in accordance with DIN

- (A)** Do not install any control valves in this area
- (B)** With pipe separation according to DIN 1717
- (C)** Low-loss header, on-site accessory

i **Important**
The AguaSave and AguaClean modules are optional accessories for conditioning heating water in accordance with VDI 2035 and the specific requirements of Potterton.

i **Important**
The generally accepted rules of technology must be observed, with particular reference to the DVGW standard W551 and drinking water regulations.

i **Important**
The circulating pump must be actuated on-site or via an additional EWM B.

Fig.18 EC five, one mixer heating circuit and hot water preparation, AguaSave and AguaClean optional (connecting diagram)

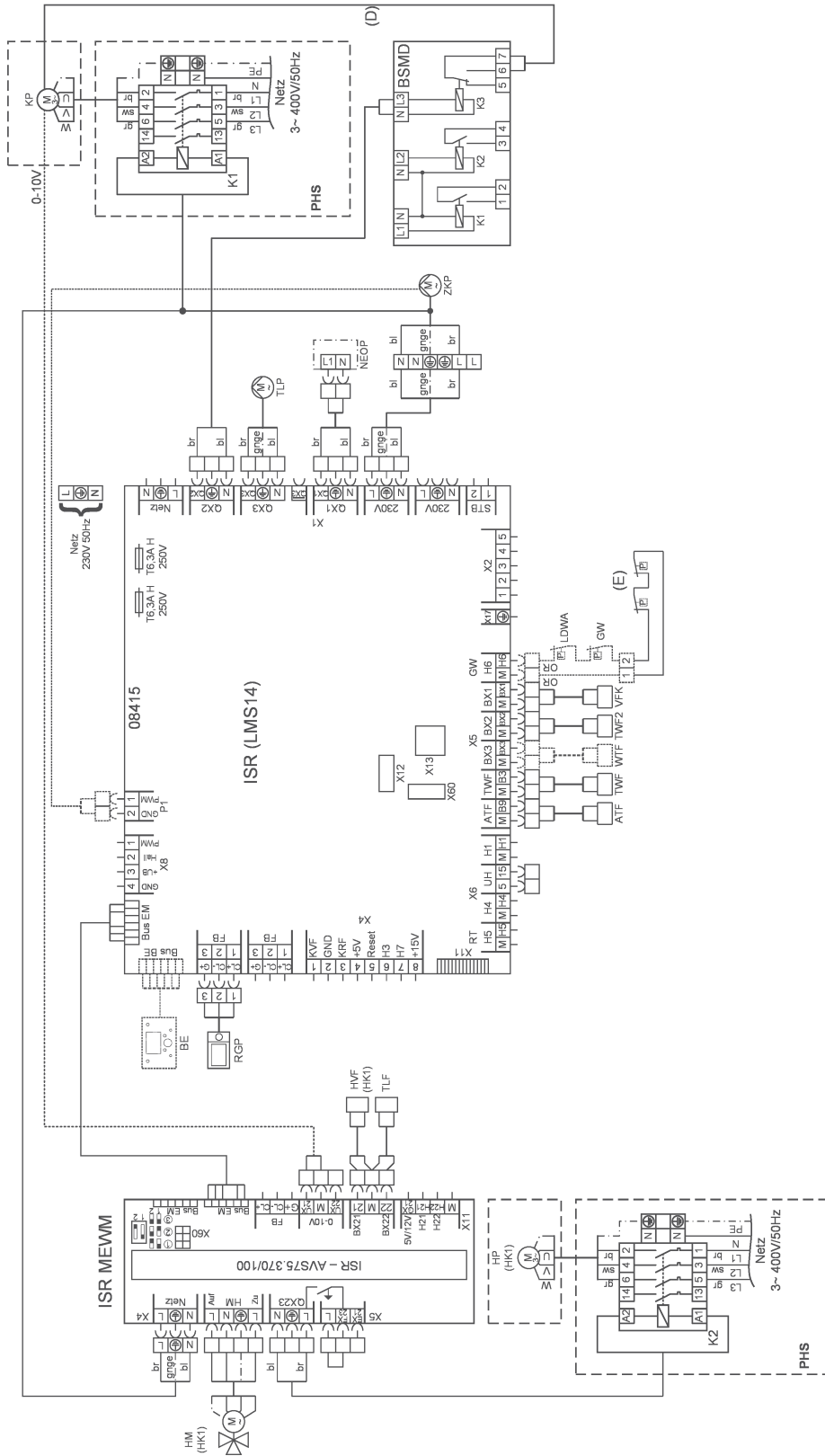

RA-08415-B02

- PHS** Pump contactor relay, can be used in EC five/UWG.
- (D)** Control signal ON/OFF
- (E)** Max. pressure limiter

- i Important**
Please firstly set all parameters from the "configuration" and Config extension module parameter groups in order to be shown the other parameters.
- i Important**
The maximum current is 1 ampere per output and 5 amperes per controller. If consumers exceed 1 ampere or 5 amperes, pump contactor relays (PHS) should be used. The pump auxiliary contactor (PHS) supplied with the EC five can be used for one pump. Additional PHS can be installed in the boiler or in universal wall-mounted housing (UWG). Cables and fuses must be dimensioned according to local conditions. The installer is responsible for this.
- i Important**
The pump's electrical connection is only shown as a general image; observe the pump's assembly instructions. Additional accessories from the pump manufacturer may be required to regulate the pump speed. The pump and connection lines for the pump must be installed on-site.
- i Important**
When using Wilo pumps, parameter 2322 must be set to min. 40%.
- i Important**
When using a 0...10V pump that does not have its own control signal (on/off), we recommend the use of a BSM D to ensure complete shutdown of the pump (for example in summer mode).

Tab.8 Parameters to be set for EC five

Menu item	Prog. no.	Setting
Boiler		
Temp differential nominal	2317	e.g. 15 °C
DHW storage tank		
Flow setpoint boost	5020	10 °C
Charging temp max	5050	69 °C
With solar integration	5093	No
Pump speed min	5101	0 %
Pump speed max	5102	100%
Intermediate circuit boost	5140	3 °C
Configuration		
Relay output QX1	5890	Status information K36
Relay output QX2	5891	Boiler pump Q1
Sensor input BX1	5930	Common flow sensor B10
Function output P1	6085	DHW interm circ pump Q33
Central setp compensation	6117	e.g. 3 °C
Config extension module		
Function extension module 1	7300	Heating circuit 1
Sensor input BX22 module 1	7308	DHW charging sensor B36
Funct output UX21 module 1	7348	Boiler pump Q1
Signal output UX21 module 1	7350	10 V

**Important**

If necessary, the modulation of the boiler pump for the heating circuits under prog. 2322 and 2323 and for drinking water under prog.-no. 5101 and 5102 must be adjusted.

If an RGP is used for HC1, the following parameters must be set on the RGP for HC1:

Tab.9 Parameters to be set for EC five

Menu item	Prog. no.	Setting
Operator section		
Used as	40	Room unit 1

5.11.2 Legend

Tab.10 Sensor names

Name in the hydraulic system	Name in the control system	Function/explanation	Type
ATF	Outdoor temperature sensor B9	Measures the outside temperature	QAC34
HVF	Flow sensor B1/B12/B16	Flow sensor for a mixer heating circuit	D 36
TLF	DHW charging sensor B36	Measures the charging temperature in the LSR domestic water charging system	D 36
TWF	DHW sensor B3	Measures the upper domestic hot water temperature	Z 36
TWF2	DHW sensor B31	Measures the lower domestic hot water temperature/buffer storage tank temperature	Z 36
VFK	Flow sensor B10	Measures the system flow temperature, e.g. downstream of the hydraulic separator	Z 36
WTF	Heat exchanger sensor	Measures the heat exchanger temperature	Z 36

Type D is a surface-contact sensor, type Z is an immersion sensor, the collector sensor has a black silicone cable and the sensors for the SOR S/M are Pt1000 sensors.

Tab.11 Pump names

Name in the hydraulic system	Name in the control system	Function/explanation
HP	Heating pump CH1 Q2 / heating pump CH2 Q6	Pump in a heating circuit
KP	Boiler pump Q1	Boiler pump for an oil-fired or gas-fired boiler (operates in parallel to the boiler)
TLP	DHW pump Q3	DHW charging pump
TZP	Circulation pump Q4	Domestic water circulation pump
ZKP	DHW interm circ pump Q33:	Domestic water pump in the secondary circuit of a storage tank charging system (e.g. LSR)

Tab.12 Valve names

Name in the hydraulic system	Name in the control system	Function/explanation
USTV	Overflow valve	Overflow valve (on site)

Tab.13 General

Abbreviation	Function/explanation
(A)	Do not install any control valves in this area
(B)	with pipe separation according to DIN 1717
BE	Operating unit in the boiler or wall-mounted controller
Bus BE	Bus connection for operating unit

Abbreviation	Function/explanation
Bus EM	Bus connection for expansion module
BXx	Multifunctional input (sensor input)
(C)	Low-loss header
FB	Remote control connection (e.g. RGP)
GW	Connection for the gas pressure monitor
HKx	Heating circuit
LDWA	Air pressure monitor flue gas
NEOP	Neutralisation Equipment without pump
Netz	Mains connection
PHS	Auxiliary contactor for the pump
PWM	Pulse width modulation
QXx	Multifunctional output
RGP	Thermostat
SIS	Safety kit
TWK	Cold domestic water
TWW	Hot domestic water
TWZ	Domestic water circulation

6 Installation

6.1 General



Danger

Some components, e.g. the preinstalled components or certain spare parts, exceed the recommended maximum lifting capacity for individual people that is recommended by employment law. Risk of personal injury caused by heavy loads.

- Do not work alone.
- Use the lifting aids.
- Secure the unit during transport.
- Do not place any other objects on the unit.



Danger

Risk of injury due to the unit tipping over!

- When using transport aids, ensure that the weight is distributed evenly.



Caution

Risk of damage to the unit caused by impact during transport.

- The unit must be protected against heavy impacts during transport.



Notice

You must ensure that any stairs and doors have sufficient passage width before transporting the unit.



Caution

During transport, only lift the unit onto load-bearing panels or the parts provided for this purpose for transport.



Notice

Always transport the boiler as close to the installation site as possible before the packaging is removed.

6.2 Assembly

Fig.19 Adjustable feet

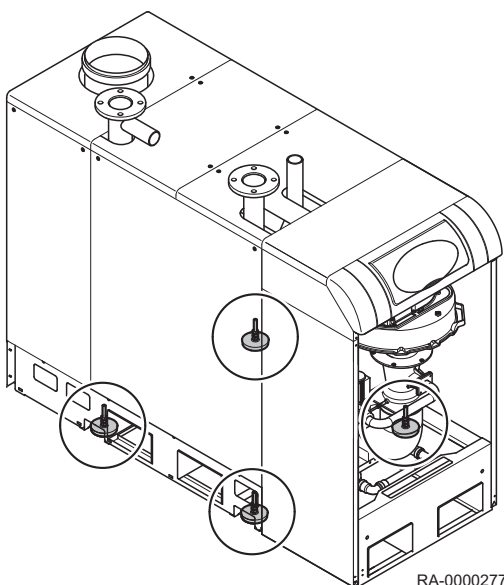

6.2.1 Positioning and levelling the boiler

The boiler has 4 adjustable feet to compensate floor unevenness. The adjustable feet are fitted with a rubber base to dampen structure-borne sound.

The boiler must be aligned horizontally at the installation location using the adjustable feet and a spirit level, so that air cannot collect in the boiler and the condensate can drain unimpeded.

**Caution****Risk of damage to boiler due to unsuitable foundation!**

The foundation must have sufficient load carrying capacity for the boiler weight.

6.2.2 Mounting the cover panels for transport openings

**Important**

The cover panels for closing the transport openings are in the accessories box, which is fastened to the wood cladding of the gas condensing boiler.

Fig.20 Side cover panels

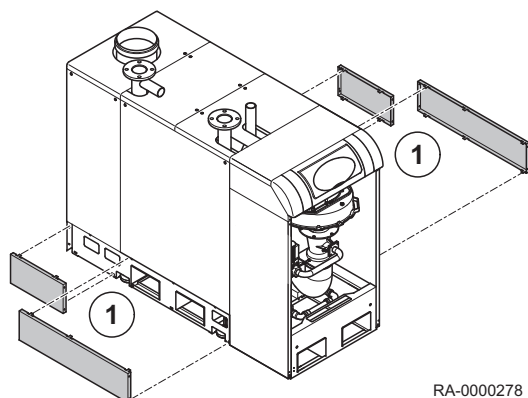

RA-0000278

Fig.21 Rear cover panel

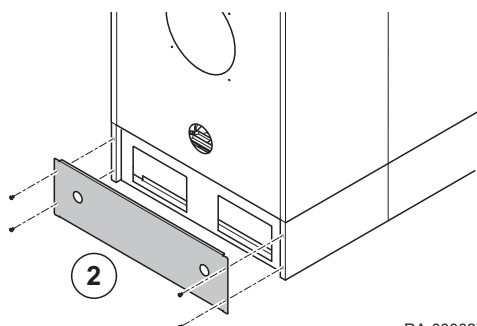

RA-0000279

1. Attach the side cover panel as shown in the illustration

2. Fit the rear cover panel to the side cover panels using the screws as shown in the illustration

Fig.22 Assembling the condensate piping

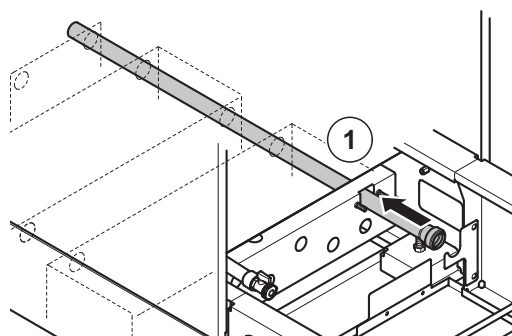

RA-0000280

6.2.3 Installing siphon and condensate piping

After the boiler has been positioned and levelled, the siphon and condensate piping must be fitted.

1. Push the condensate piping as far as it will go through the front fastening hole and the support holes inside the boiler as shown in the illustration.

Fig.23 Assembling the pipe fixtures

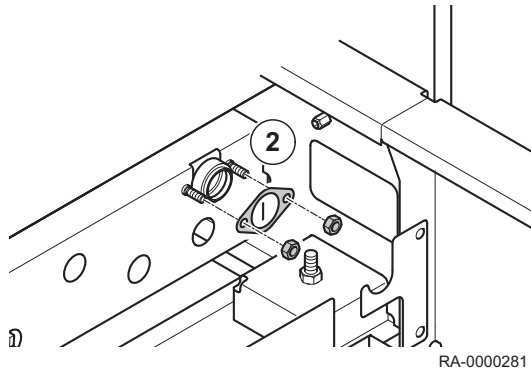

2. Fasten the condensate piping with pipe fasteners

Fig.24 Assembling the long pipe section

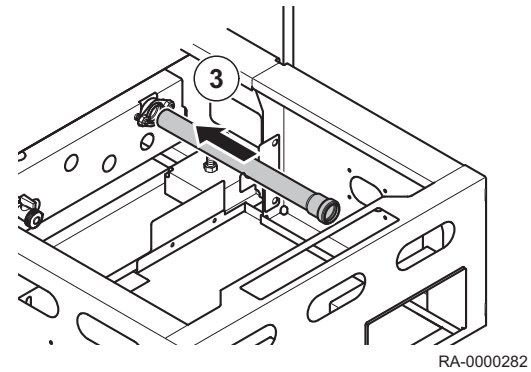

3. Insert the long straight piece of pipe as far as it will go into the front end of the condensate piping

Fig.25 Assembling the siphon adapter

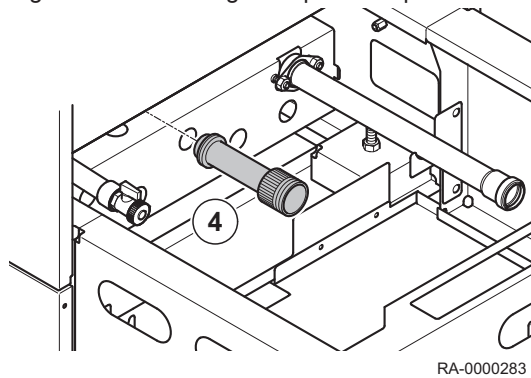

4. Screw the siphon adapter into the thread of the condensate trough

Fig.26 Assembling the siphon

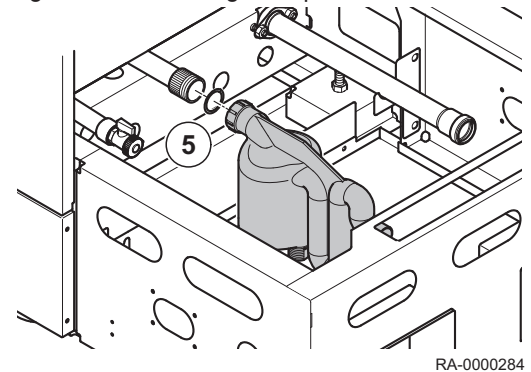

5. Screw the siphon with the included seal to the previously installed siphon adapter



Danger

Risk of life due to escaping flue gas!

Before installing the siphon and commissioning of the gas condensing boiler, fill the siphon with approx. 1 l water!

Fig.27 Assembling the remaining pipe sections

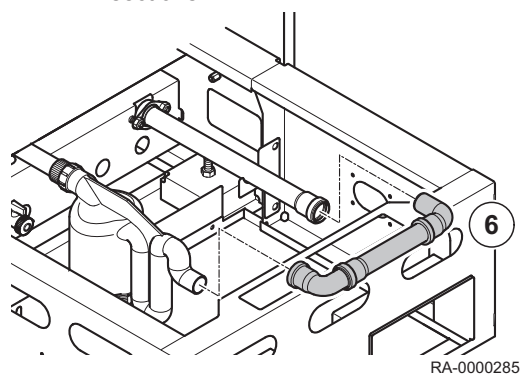

RA-0000285

6. Fit the remaining pipe sections together as shown in the illustration and install

**Danger****Risk of life due to escaping flue gas!**

The condensate piping must be checked for leaks!

6.2.4 Converting the flue gas connection

For trouble-free operation of the EC five sufficiently dimensioned inlet and outlet air openings are necessary. It has to be checked that these exist and are fully functional.

**Caution**

It has to be pointed out to the customer that these inlet and outlet air openings must always be functional, i.e. they must not be restricted or blocked, and that the inlet area for combustion air at the boiler bottom must be kept free.

Fig.28 Removing the top cladding

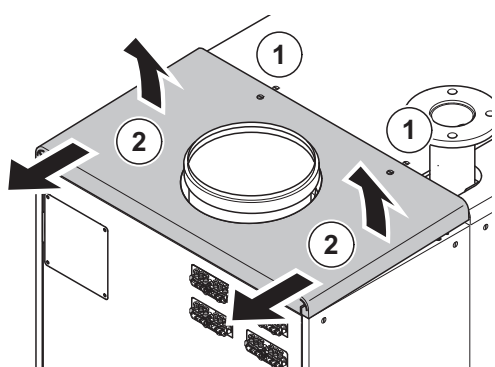

RA-0000286

1. Loosen the locking screws
2. Lift the upper cladding slightly according to the figure and pull towards the back

Fig.29 Removing the bottom cover panel

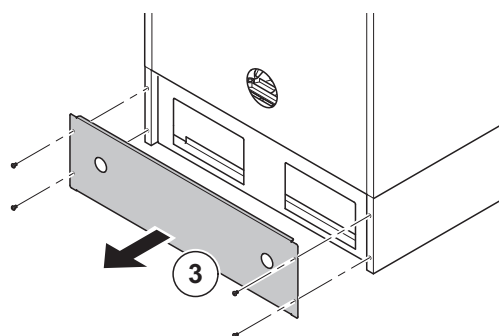

RA-0000291

3. Loosen the screws and remove the bottom cover panel

Fig.30

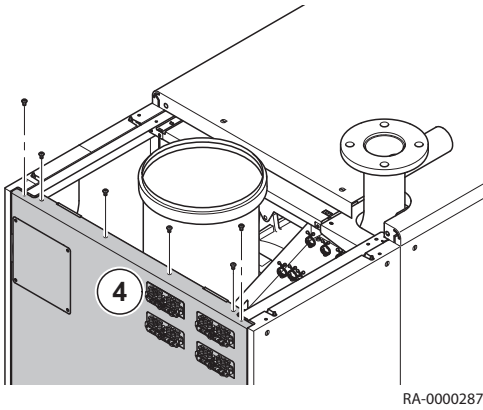

RA-0000287

4. Loosen the upper fastening screws



Important

Both outer screws have a lip and are used for fixing the upper cladding. When reinstalling the rear wall they must absolutely be screwed back on the outside.

Fig.31 Loosening the lower fastening screws

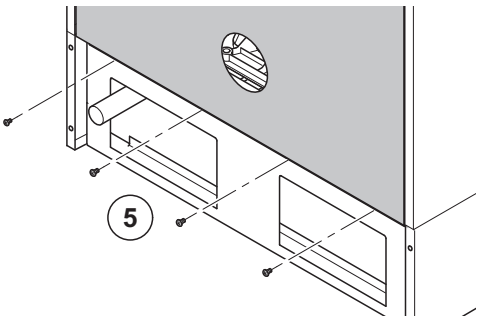

RA-0000288

5. Loosen the lower fastening screws

Fig.32 Removing the rear wall

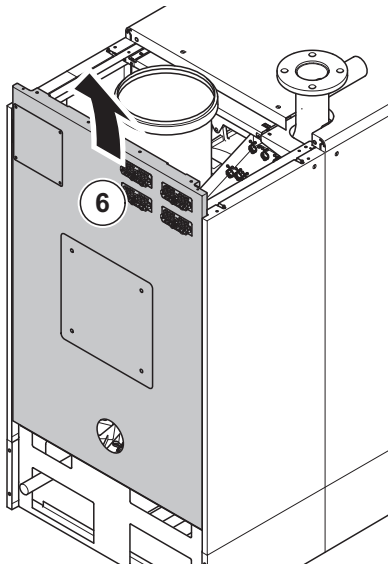

RA-0000289

6. Lift the rear wall up slightly and remove it

Fig.33 Installation of the 87° elbow (accessory)

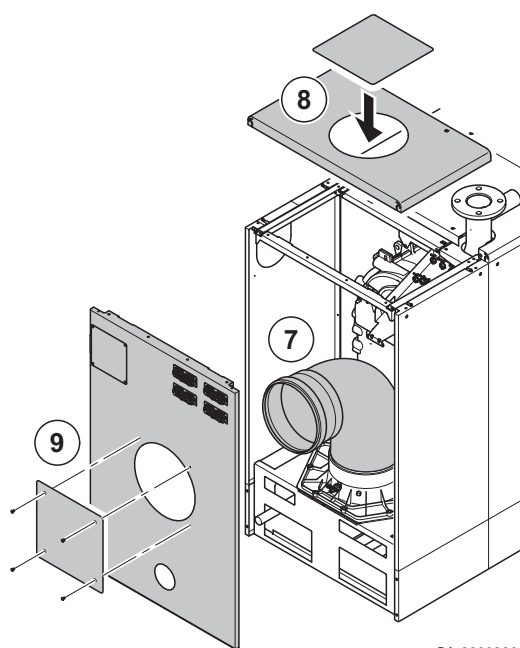

RA-0000290

7. Remove the flue gas connection leading upward and insert an 87° elbow; make sure that the seal is fitted properly
8. Screw the cover plate on the upper cladding in place
9. Loosen the screws and remove the cover plate from the rear wall
10. Replace the rear wall, upper cladding and lower cover panel



Danger

Risk of life due to escaping flue gas!

Before commissioning the gas condensing boiler the flue gas pipes must be checked for leaks.

6.2.5 Flue gas connections and air supply ducts

For trouble-free operation of the EC five sufficiently dimensioned inlet and outlet air openings are necessary. It has to be checked that these exist and are fully functional.



Caution

It has to be pointed out to the customer that these inlet and outlet air openings must always be functional, i.e. they must not be restricted or blocked, and that the inlet area for combustion air at the boiler bottom must be kept free.

■ Outlet toward the rear

The following steps describe how to install the air supply duct where the outlet is at the rear

1. Remove the upper casing at the back (see *Converting the flue gas connection*)
2. Loosen screws and remove rear cover plate
3. Fit the straight intake pipe as shown in the illustration
4. Replace upper casing

Fig.34 Installation of the straight intake pipe

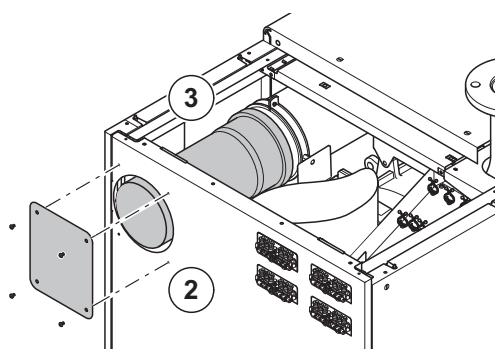

RA-0000292

■ Outlet toward the side

The following steps describe how to install the air supply duct where the outlet is at the side

1. Remove the upper casing at the back (see *Converting the flue gas connection*)

Fig.35 Installing the intake pipe elbow

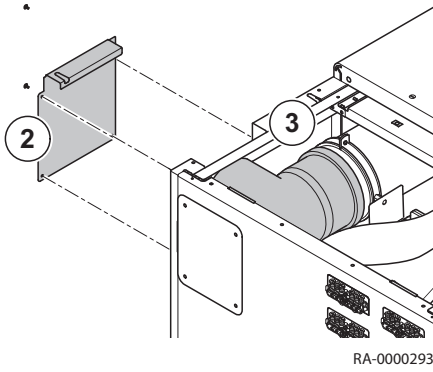

2. Loosen screws and remove side cover plate
3. Fit the suction pipe elbow
4. Replace upper casing

6.3 Hydraulic connections

6.3.1 Connecting the heating circuit

Connect the heating circuit at the heating flow (HV) and the heating return (HR) on the top of the EC five. The use in closed systems is not permitted.



Important

Installation of a filter is recommended in the heating return. In the case of old systems, the whole heating system should be thoroughly flushed before installation.

6.3.2 Safety valve

Install diaphragm expansion vessel and safety valve.



Caution

The connecting pipe between boiler and safety valve must not be blockable. The installation of pumps and fittings or pipe reducer pieces is not permissible. The blow-off line of the safety valve must be designed in such a way that the pressure does not increase when the safety valve responds. It must not be routed to the outside, the opening must be clear and observable. Any heating water that may possibly escape should be safely drained off.

6.3.3 Condensate connection

Condensate connection

The condensate piping of the EC five must be installed according to the section *Installing siphon and condensate piping*. If there is no run-off facility underneath the condensate discharge, the use of Potterton neutralisation and syphoning system is recommended.



For more information, see

Installing siphon and condensate piping, page 47

■ **Draining condensate**

The ATV worksheet A 251 can be used as a guideline for draining the condensate into the public sewage system. The requirements for the condensate contents according to ATV worksheet A21 are met by all boilers of the EC five series. Since ATV worksheet A 251 is only a recommendation, the local condensate draining conditions must be agreed upon with the local authorities.

■ **Neutralisation equipment**

The continuous neutralisation equipment NEOP is available as an accessory for the condensate neutralisation.

The neutralisation equipment must be checked at least once annually. Since the condensate volume can be very different depending on the system conditions, checks at a shorter interval are recommended after the heating system has been put into operation initially. The effectiveness of the neutralisation granulate is controlled using pH testers (available at chemists and from chemical supplies retailers), which are sprayed with the draining condensate. The waste water should have a pH value of at least 6.5. A pH-value below 6.5 indicates a depletion of the neutralisation agent. In this case, refilling with the granulate available as a special accessory is required. The neutralisation granulate HYDRALIT is made of magnesium oxide. It is ecologically harmless and can be used as fertiliser. Both residues as well as unused material can be disposed in rubbish or together with construction waste.

The granulate disposes of itself automatically. The carbon dioxide in the condensate combines with the granulate to form magnesium hydrogen carbonate $Mg(HCO_3)_2$. This is a fully soluble salt which is commonly found in nature. The granulate is approved for DHW treatment. Granulate residue can be disposed of with normal household waste.

If direct drainage is not possible, a commercially available condensate pump can be connected to the neutralisation equipment NEOP.

6.4 Gas connection

6.4.1 Gas connection

The gas-side connection may only be carried out by an approved installer. For the gas-side installation and setting, the factory setting data of the equipment and optional label should be compared with the local supply conditions.

An approved thermally activated disconnecter valve must be installed upstream of the gas condensing boiler.

If old gas pipes still exist in the region, the installation of a gas filter is recommended.

Residues in pipes and pipe joints should be removed.

6.4.2 Check tightness



Danger

Danger! Danger to life by gas!

The entire gas inlet pipe, particularly the joints, must be checked for leakages before commissioning.

The gas burner valve on the gas burner must be pressure- tested at maximum of only **100mbar**

6.4.3 Venting the gas line

The gas line must be vented before initial commissioning.

For this, open the measuring nozzle for the connecting pressure and vent, taking the safety precautions into account. Check for tightness of the connection after venting.

**Danger
Danger to life by gas!**

- The entire gas pipe, particularly the joints must be checked for leakages before commissioning.

6.5 Air supply/flue gas outlet connections

6.5.1 Cleaning and inspection openings

**Danger
Clean flue gas pipes!**

It should be possible to clean the flue gas pipes and inspect their free cross-section and airtightness.

At least one cleaning and inspection opening must be installed in the installation room of the EC five.

Flue gas pipes in buildings which cannot be cleaned or inspected from their port side must have an additional cleaning port in the upper part of the flue gas system or via the roof.

The flue gas pipes on the outer wall must have at least one cleaning opening in the lower part of the flue gas system. .

The ducts for the flue gas system must not have any openings other than the necessary cleaning and inspection ports as well as openings for back ventilation of the flue gas pipe.

6.6 Electrical connections

6.6.1 Electrical connection (general)

**Danger of electric shock
Danger to life through incorrect work!**

All electrical work in connection with the installation may only be carried out by a trained electrician.

- Mains supply AC 230 V +6% -10%, 50 Hz

In Germany the VDE 0100 and local regulations must be followed during installation; in all other countries, follow the relevant regulations.

The electrical connection should be made with correct and non-reversible polarity. In Germany the connection can be executed as an accessible plug and socket connection with non-reversible polarity or as a fixed connection. In all other countries, a fixed connection must be provided.

For the power supply, use the power cable attached to the boiler or cable types H05VV-F 3 x 1 mm² or 3 x 1.5 mm². The earthing cable must be longer at the connection in order to guarantee that this connection is the last cable to rupture in the event of a hazard.

**Important**

For boilers with a total rated output of more than 100 kW, a switch (emergency switch) must be fitted in front of the boiler outside the room where the boiler is installed. This switch should be identified by a sign featuring the text "EMERGENCY SWITCH FOR BOILER".

All connected components must be executed compliant with VDE regulations. Always apply strain relief to connecting cables.

Cable types

**Danger of electric shock****Danger to life! Risk of injury or a risk to life from electric shock!**

The use of rigid lines (e.g. NYM) is not allowed because of the risk of cable damages! There are only to use flexible cables, e.g. H05VV-F for high voltage power cables, and e.g. LIYY for sensor cables.

6.6.2 Cable lengths

Bus/sensor lines do not have mains voltage, but safety extra-low voltage. They must **not be routed in parallel to the mains cables** (interference signals). Otherwise shielded cables must be installed.

Pipe length permitted:

- Cu-cable up to 20 m: 0.8 mm²
- Cu-cable up to 80 m: 1 mm²
- Cu-cable up to 120m: 1.5 mm²

Cable types : e.g. LIYY or LiYCY 2 x 0.8

6.6.3 Strain reliefs

All the cables should be fixed in the strain relief clamp of the control panel and connected according to the connection diagram.

Fig.36 Strain reliefs

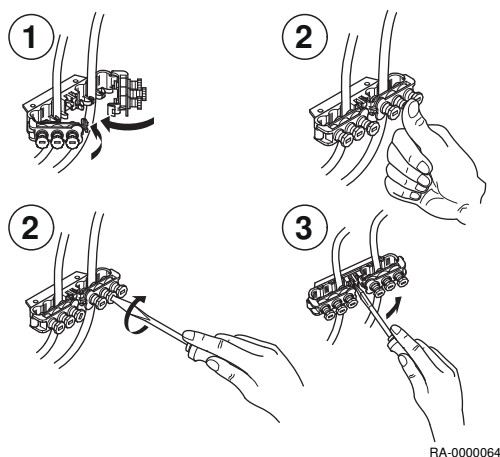

RA-000064

6.6.4 Circulating pumps

The permissible current load per pump output is $I_{N \max} = 1A$.

6.6.5 Appliance fuses

Appliance fuse in the control unit ISR:

- Mains fuses: T 6.3A H 250V

6.6.6 Connecting sensors/components

**Danger****Risk of electric shock! Danger to life through incorrect work!**

The wiring diagram must be followed! Optional accessories must be fitted and connected according to the instructions provided. Connect to the mains. Check earthing.

Outdoor temperature sensor (included in delivery)

The outdoor temperature sensor is located in the accessory bag. It should be connected according to the wiring diagram.

6.6.7 Replacing cables

All connecting cables, except for the mains connection cable, have to be replaced by Potterton special cables in case of replacement. When replacing the mains connection cable, only cables of the types H05VV-F 3 x 1 mm² or 3 x 1,5 mm² have to be used.

6.6.8 Protection against contact

After the EC five has been opened, the cladding parts to be screwed on should be screwed back on with the appropriate screws to ensure protection against contact.

6.6.9 Electrical connection of the auxiliary contactor for the pump PHS

The auxiliary contactor for the pump PHS is used to operate three-phase current pumps or one-phase pumps with a current rating of more than 1 A, and is located under the front casing cover on the right-hand side.

⚡ Danger of electric shock
⚡ Danger to life due to electric current!
 All electrical work in connection with the installation may only be carried out by a trained electrician. Prior to commencing any installation work, isolate the boiler from the power supply and safeguard against unintentional reconnection!

i Important
 Dimensioning of the connection cables and fuses used must be in accordance with the on-site situation. The installer is responsible for this.

- Connect the auxiliary contactor for the pump PHS in accordance with the connection diagram
- Route the connection cables from the pump to the boiler and connect them to the auxiliary contactor PHS in accordance with the connection diagram.

i Important
 The connection cables must be fixed in place on either side using the plastic ties available.
 The connection cables must be fixed in the strain reliefs available.

Fig.37 PHS in EC five

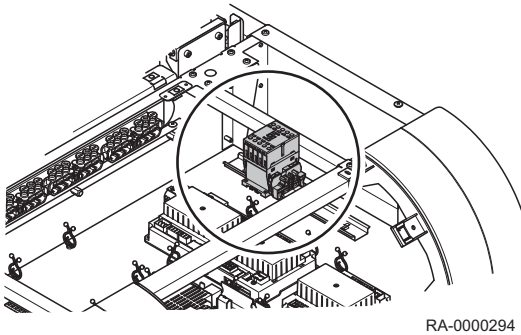

RA-0000294

Fig.38 Connection diagram PHS

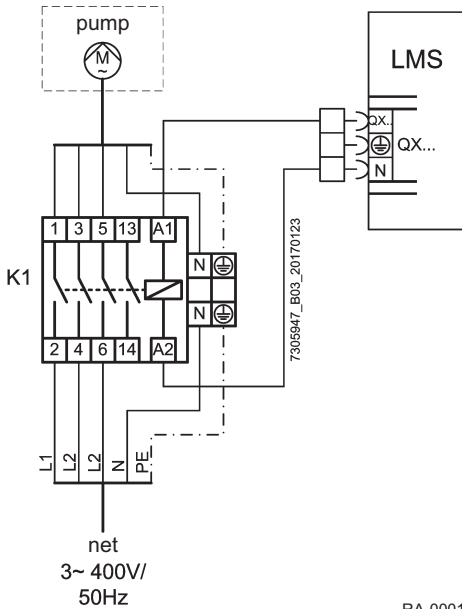

RA-0001040

Fig.39 Opening the terminal strip contacts

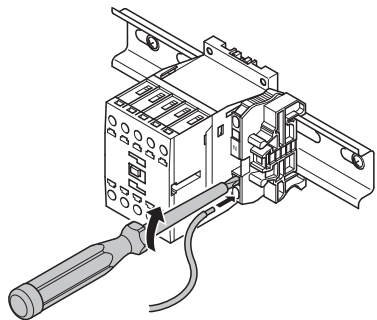

RA-0000296

- Insert a screwdriver into the terminal strip as shown and lever it open
- Insert the connection cables into the terminal contacts and remove the screwdriver



For more information, see

Technical data for the auxiliary contactor for the pump PHS, page 15

6.7 Filling the system

1. Fill the heating system using the boiler fill and drain valve (BFD valve) of the EC five
2. Control the heating system for leaks



For more information, see

Boiler, page 23

7 Commissioning

7.1 General



Danger

Commissioning may only be carried out by an approved installer. The installer checks the tightness of pipes, the correct function of all regulating, control and safety equipment, and measures the combustion values. If this work is not carried out correctly, there is a risk of considerable damage to persons, environment and property.

7.2 Checklist for commissioning

Tab.14 Checklist for commissioning

1.	System location			
2.	Customer			
3.	Boiler type/Designation			
4.	Serial number			
5.	Characteristic gas values	Wobbe index	kWh/m ³	
6.		Operating heating value	kWh/m ³	
7.	Have all pipelines and connections been checked for tightness?			<input type="checkbox"/>
8.	Flue gas system checked?			<input type="checkbox"/>
9.	Gas pipeline checked and vented?			<input type="checkbox"/>
10.	Static pressure measured at the gas valve inlet?		mbar	
11.	Free wheeling of pumps checked?			<input type="checkbox"/>
12.	Filling the heating plant			<input type="checkbox"/>
13.	Water additives used			
14.	Gas flow pressure measured at full load at the gas valve inlet?		mbar	
15.	Gas injector pressure measured at full load at the gas valve outlet?		mbar	
16.	CO ₂ content at low load		%	
17.	CO content at low load		ppm	
18.	CO ₂ content at full load		%	
19.	CO content at full load		ppm	
20.	Function test:	Heating mode		<input type="checkbox"/>
21.		Domestic water mode		<input type="checkbox"/>
22.	Programming:	Time /date		<input type="checkbox"/>
23.		Comfort setpoint heating circuit 1/2	°C	
24.		Setpoint DHW	°C	
25.		Automatic day time programme	Clock	
26.		Heating curve checked?		<input type="checkbox"/>
27.	Tightness of the flue system checked in operation (e.g. CO ₂ test in annular gap)?			
28.	Customer instructed?			<input type="checkbox"/>
29.	Documents handed over?			<input type="checkbox"/>
Only components tested and marked according to the respective standard have been used. All system components have been installed according to the instruction of the manufacturers. The whole system conforms to the standard. To ensure the heat source operates reliably and economically for a long period, we recommend annual maintenance for the heat generator.				Date /signature Company stamp

7.3 Commissioning procedure

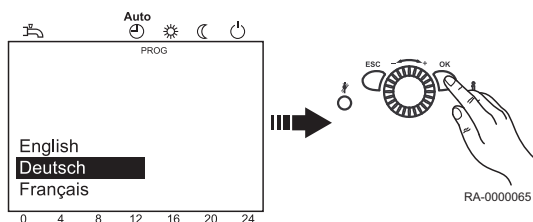

7.3.1 Commissioning menu

The commissioning menu will be shown once during initial commissioning.

1. Select Language and confirm with **OK-Taste**.
2. Select Year and confirm.
3. Set Time of day and date and confirm.
4. Conclude by pressing the **OK-Taste**.



Important

If the commissioning menu entry is terminated by pressing **ESC-Taste**, the menu will be shown again next time the appliance is switched on.

7.4 Gas settings

7.4.1 Factory settings

The EC five has been set to the nominal heat load by the manufacturer.

- Gas type G20 (natural gas G20 with Wobbe index $W_{oN} = 15.0 \text{ kWh/m}^3$)

The specific set gas type can be seen on the optional label glued to the burner. The factory setting data must be checked against the on-site supply conditions before installation of the EC five.

7.4.2 CO₂ content

The CO₂ content in the exhaust gas must be checked during commissioning and during regular maintenance of the boiler, as well as after reconstruction work on the boiler or on the exhaust gas system.

CO₂ content during operation see section *Technical data*.



Caution

Risk of damage to the burner!

Too *high* CO₂ values can lead to unhygienic combustion (high CO values) and damage to the burner.

Too *low* CO₂ values can lead to ignition problems.

The CO₂ value is set by adjusting the gas pressure at the gas valve. If the EC five is used in areas with fluctuating natural gas composition, the CO₂ content must be adjusted in accordance with the Wobbe index at any given time (ask the gas supply company).

The CO₂ content to be set can be decided as follows:

- CO₂-content = $9,0 - (W_{oN} - W_{ocurrent}) * 0,5$



Important

The air quantity set in the factory must not be changed.

7.4.3 Manual adjustment of burner output (controller stop function)

For controlling the CO₂ values the EC five operated in the **control stop function**

1. Press button **Operating mode button heating operation** for approx 3 s
⇒ The message Controller stop active is displayed.
2. Wait until the display has reached the basic display again.

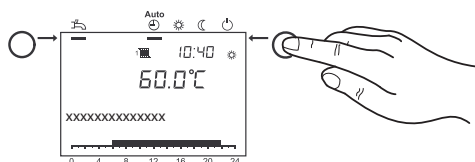

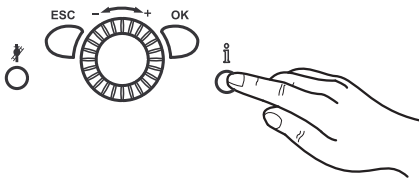

3. Press the Info button
⇒ The message Controller stop setpoint appears on the display. The actual modulation degree will be displayed on the display.
4. Press OK.
⇒ The setpoint can now be changed.
5. Press OK.
⇒ The setpoint displayed is then adopted by the controller.

i Important
The regulator stop function is stopped by pressing the **operating mode button Heating Operation** for approximately 3 seconds, reaching the maximum boiler temperature or a time limit. If there is demand for heat from a coiled tubing storage tank, this demand will continue to be met during the controller stop function.

7.4.4 Adjusting CO₂ content

Fig.40 Gas valve EC five 400 kW - 540 kW (Honeywell)

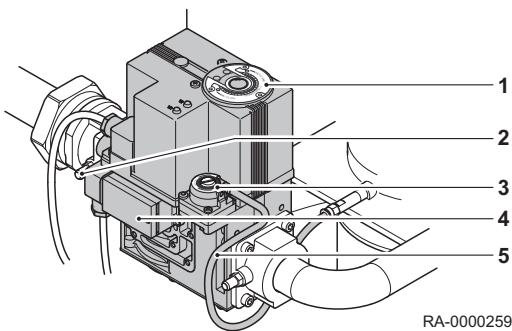

RA-0000259

- 1 Adjustment screw for full load (3 mm Allen key)
- 2 Measuring nozzle for inlet pressure
- 3 Adjustment screw for small load (3 mm Allen key)
- 4 Gas pressure monitor
- 5 Compensation line

Fig.41 Gas valve EC five 610 kW (Dungs)

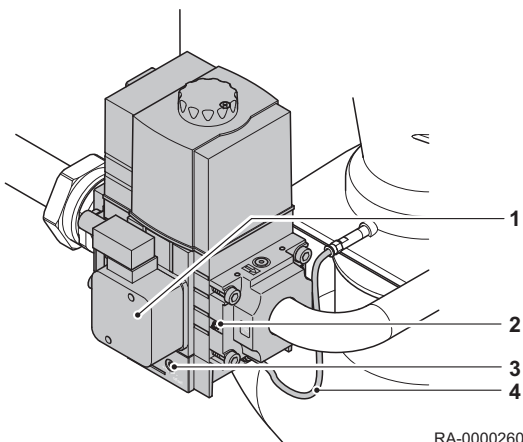

RA-0000260

- 1 Gas pressure monitor
- 2 Adjustment screw for full load (screwdriver)
- 3 Adjustment screw for small load (2.5 mm Allen key)
- 4 Compensation line

■ CO₂ content at max. output (EC five 400 kW - 540 kW)

1. EC five in the control stop function operated at maximum value (refer to the section *Control stop function*)
2. Remove safety cap from the adjustment screw for full load
3. Use a 3 mm Allen key to set CO₂ content at the adjustment screw for full load according to the *Technical data*
 - 3.1. Clockwise: CO₂ content is decreased
 - 3.2. Counter-clockwise: CO₂ content is increased
4. Replace safety cap on the adjusting screw for full load

■ CO₂ content at min. output (EC five 400 kW - 540 kW)

1. EC five in the control stop function operated at minimum value (refer to the section *Control stop function*)
2. Remove safety cap from the adjustment screw for small load

3. Use a 3 mm Allen key to set CO₂ content at the adjustment screw for small load according to the *Technical data*
 - 3.1. Clockwise: CO₂ content is increased
 - 3.2. Counter-clockwise: CO₂ content is decreased
4. Replace safety cap on the adjusting screw for small load

**Important**

After successful adjustment of the gas valve, the CO₂ content must again be controlled at maximum and minimum output and corrected if necessary

**For more information, see**

Technical data, page 14
Manual adjustment of burner output (controller stop function), page 59

■ CO₂ content at max. output (EC five 610 kW)

1. In the control stop function (refer to the section *Control stop function*) operate the EC five at maximum value
2. Set CO₂-content with the adjustment screw for full load (2) according to the section *Technical Data* with a screwdriver
 - 2.1. Clockwise: CO₂ content is increased
 - 2.1. Counter-clockwise: CO₂ content is decreased

■ CO₂ content at min. output (EC five 610 kW)

1. EC five In the control stop function (refer to the section *Control stop function*) operated at minimum value
2. Use a 2.5 mm Allen key to set CO₂ content at the adjustment screw for small load according to the *Technical data*
 - 2.1. Clockwise: CO₂ content is increased
 - 2.2. Counter-clockwise: CO₂ content is decreased

**Important**

After successful adjustment of the gas valve, the CO₂ content must again be controlled at maximum and minimum output and corrected if necessary

**For more information, see**

Technical data, page 14
Manual adjustment of burner output (controller stop function), page 59

7.5 Final instructions

7.5.1 Instruction of the customer

The customer must be given full explanation of the heating system and how the protective installations work. He must be especially instructed about the following:

- The supply air opening must not be closed or restricted
- The connection nozzle for the combustion air at the top of the device must be accessible for the chimney sweep
- The following control checks himself that he has to perform himself:
 - Pressure check on the manometer
 - Check of the receiver under the blowpipe of the safety valve
- Only an approved heating specialist may carry out the inspection and cleaning work at intervals.

7.5.2 Documents

- The documents belonging to the heating plant must be handed over to the customer with the instruction that they have to be kept in the boiler installation room.
- System log with checklist for commissioning with confirmation and legally binding signature handed to the customer: Only components tested and marked according to the respective standard have been used. All components have been installed according to the manufacturer's instruction. The whole system conforms to the standard.

8 Operation

8.1 Use of the control panel

8.1.1 Changing parameters

Settings which are not directly changed via the operating panel must be carried out on the setting level.

The basic programming process is depicted in the following using the example of the setting of Time of day and date.

1. Press **OK**.
⇒ The menu items under the *End user* level are displayed.



Important

If parameters are to be changed on a level other than the end user level, please see the note below!

2. Use the control knob to select the menu item Time of day and date.
3. Press **OK**.

4. Use the control knob to select the menu item Hours / minutes.
5. Press **OK**.

6. Carry out hour setting (e.g. 15 h) using the control knob.
7. Press **OK**.

8. Carry out minute setting (e.g. 30 minutes) with the control knob.
9. Press **OK**.

10. Leave the programming level by pressing the **operating mode key for heating mode**.



Important

The previous menu item is retrieved by pressing the **ESC key** without applying previously modified values. If no settings are carried out for approximately 8 minutes, the basic display is called up without applying previously modified values.

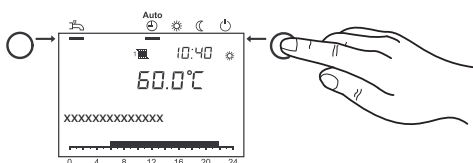
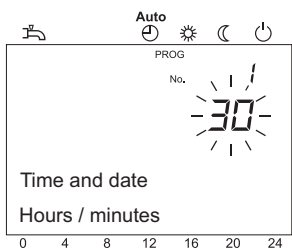
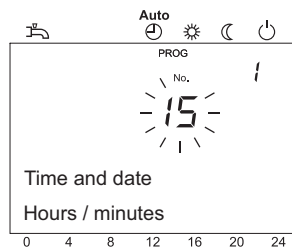
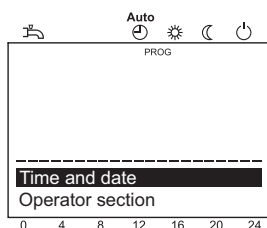
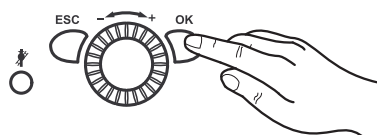

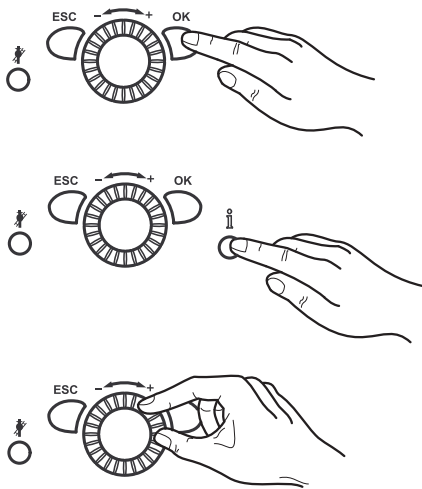

8.1.2 Programming procedure

The selection of the setting levels and menu items is done as follows:

1. Press **OK**.
⇒ The menu items under the *End user* level are displayed.
2. Press **information button** for approx. 3 s.
⇒ The setting levels appear.
3. Select the required setting level using the control knob.

Setting levels
- End user (Eu)
- Commissioning (C), incl. end user (Eu)
- Engineer (E), incl. end user (Eu) and commissioning (C)
- OEM, includes all other setting levels (password-protected)

4. Press **OK**.
5. Select the required menu item (see parameter list) using the control knob.



Important

Not all menu items will be visible, depending on the selection of the programming level and the programming.

8.2 Start-up

8.2.1 Checking water pressure



Caution

Before switching on, check whether the pressure gauge indicates sufficient water pressure. The value for the water pressure is set by the installer during Installation.

- If the value is under the value specified by the installer: Top up water.
- If the value is above the value specified by the installer: Do not start the gas condensing boiler. Drain the water.

8.2.2 Switching on

This section describes which steps are necessary to switch the boiler on.

1. Switch on heating emergency switch
2. Open gas shut-off device
3. Open the disconnector valves at the heating flow and heating return on the boiler.
4. Open the operating panel cover and switch the ON/OFF switch on the operating panel of the boiler to on.

①

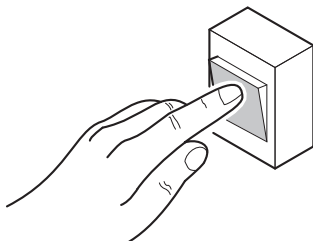

RA-0000162

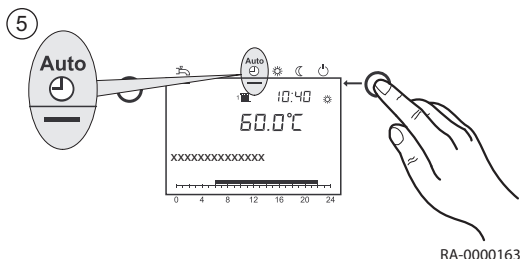

5. Use the **operating mode key for heating mode** to select the automatic operating mode on the boiler control unit 

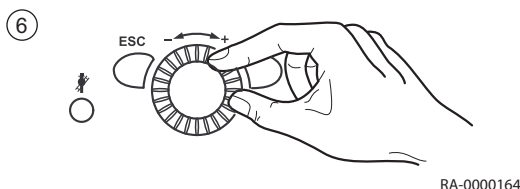

6. Set the required room temperature using the control of the control unit

8.2.3 Setting necessary parameters

Normally, the parameters of the regulator do not need to be modified. Only date/time and individual time programs may need setting.

For DHW processing a setting of 55°C is recommended.





Important

Times for domestic water heating are set in time program 4 / DHW. **For reasons of convenience, domestic water heating should start approx. 1 h before central heating commences.**

8.2.4 Setting the heating mode

The **operating mode key for heating mode** enables a changeover between the various heating operating modes. The selected setting is marked with a bar underneath the operating mode symbol.

Automatic mode

- Heating mode according to time program
- Temperature setpoints  or  according to time program
- Protection functions (plant frost protection, overheating protection) activated
- Automatic summer/winter changeover (automatic switching over between heating and summer operation from a certain outside temperature onwards)
- Automatic day heating limit (automatic changeover between heating and summer operation, if outside temperature exceeds the room setpoint value)

Continuous mode or

- Heating mode without time program
- Protection functions activated
- Automatic summer/winter changeover is not activated
- Automatic day heating limit is not activated

Protection mode

- No heating operation
- Temperature according to frost protection setpoint
- Protection functions activated
- Automatic summer/winter changeover active
- Automatic day heating limit active

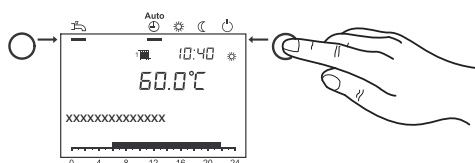

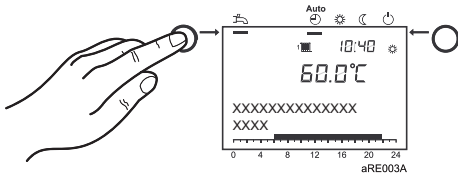

8.2.5 Adjusting domestic water mode

- Switched on Domestic water is prepared according to the selected switching programme.
- Switched off Domestic water preparation has been de-activated.

i Important

- A setting between 50 and 60°C is recommended for domestic water heating.
- Times for domestic water heating are set in time program 4 / DHW.

For reasons of convenience, domestic water heating should start approx. 1 h before central heating commences.

i Important Legionella function

Each Sunday during the first charge of the DHW tank, the legionella function is activated; this means the DHW is being heated up to 65 °C once for eliminating the existing legionellas.

8.2.6 Adjusting comfortable room setpoint

How to adjust the comfortable room setpoint is described here.

1. Set the comfort setpoint using the control knob.
⇒ => The value is taken over automatically.

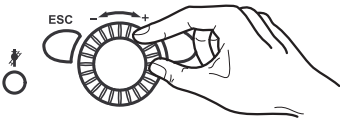

8.2.7 Setting reduced room setpoint

How to set the reduced room setpoint is described here.

1. Press **OK**.
2. Select the Heating circuit menu item.
3. Press **OK**.
4. Select the Reduced setpoint parameter.
5. Press **OK**.
6. Set the reduced setpoint at the control knob.
7. Press **OK**.
8. Leave the programming level by pressing the **operating mode key for heating mode**.

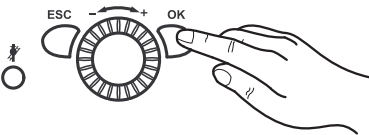

8.2.8 Emergency mode (Manual control)

If the manual control function is activated the boiler is controlled to the setpoint manual control. All the pumps are switched on. Additional requests e.g. for heating domestic water are ignored.

■ Activating emergency operation

1. Press **OK**.
2. Request the menu item Maintenance.
3. Press **OK**.
4. Request the parameter Manual control (prog. no. 7140).
5. Press **OK**.
6. Select the parameter On.
7. Press **OK**.
8. Leave the programming level by pressing the **operating mode key for heating mode**.

■ Adjusting setpoint for emergency operation

Using the operation mode "manual operation" you can choose a nominal temperature value for it:



1. Press the **information key**.
2. Press **OK**.

3. Adjust nominal value by using rotating knob
4. Acknowledge setting with **OK**.

8.2.9 Chimney sweep function

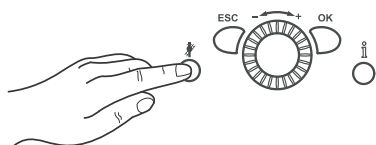
The chimney sweep function is activated or deactivated using the **Chimney-sweep button**.



1. Press the **Chimney-sweep button** .
 - ⇒ The activated special function is displayed by the symbol  in the display.



Important

If there is demand for heat from a coiled tubing storage tank, this demand will continue to be met while the emissions test function (chimney sweep function) is running.

8.2.10 Restoring factory settings

The factory settings are restored as follows:

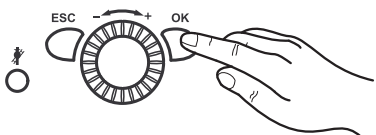

1. Press OK button
2. Select setting level Engineer
3. Select parameter Activate basic settings (prog. no. 31)
4. Change setting to "Yes" and wait until setting returns to "No"
5. Press ESC button
 - ⇒ The factory settings have been restored.

9 Settings

9.1 List of parameters



See

Subject to system configuration, not all parameters listed in the parameter list will be shown on the display.

To reach the end user (Eu), Commissioning (C) and Engineer (E) setting levels:

1. Press the **OK button**.
2. Then press the **information button** for approx. 3 s.
3. Select the circuit using the control knob.
4. Confirm with the **OK button**.

Time of day and date	Prog. no.	Level	Standard value
Hours / minutes	1	Eu	01:00 (h:min)
Day / month	2	Eu	01.01 (day.month)
Year	3	Eu	2030 (year)
Start of summertime	5	E	25.03 (day.month)
End of summertime	6	E	25.10 (day.month)

Operator section	Prog. no.	Level	Standard value
Language	20	Eu	German
Info Temporarily Permanently	22	E	Temporarily
Display of errors Code Code and text	23	E	Code and text
Contrast of display	25	Eu	—
Operation lock Off On	26	E	Off
Programming lock Off On	27	E	Off
Units °C, bar °F, PSI	29	Eu	°C, bar
Save basic settings ⁽¹⁾ No Yes	30	E	No
Activate basic settings ⁽²⁾ No Yes	31	E	No
Used as ⁽³⁾ Room unit 1 Room unit 2 Room unit 3/P Operator unit 1 Operator unit 2 Operator unit 3 Service unit	40	C	Room unit 1
Assignment device 1 ⁽¹⁾ Heating circuit 1 Heating circuits 1 and 2 Heating circuits 1 and 3/P All heating circuits	42	C	Heating circuit 1
Operation HC2 Jointly with HC1 Independently	44	C	Jointly with HC1
Operation HC3/P Jointly with HC1 Independently	46	C	Jointly with HC1
Room temperature device 1 ⁽¹⁾ Heating circuit 1 only For all assigned HCs	47	C	For all assigned HCs
Occupancy button device 1 ⁽¹⁾ None Heating circuit 1 For all assigned HCs	48	C	For all assigned HCs
Readjustment room sensor ⁽¹⁾	54	E	0.0 °C
Software version	70	E	—

(1) This parameter is only visible in the room device!

(2) This parameter is only visible if a suitable standard setting is available in the operating unit!

(3) This parameter is only visible in the room device, as the operating unit in the boiler is programmed permanently to the operating unit.

Wireless ⁽¹⁾	Prog. no.	Level	Standard value
Room unit 1 Missing In operation No recept'n Change batt	130	C	Missing
Room unit 2 Missing In operation No recept'n Change batt	131	C	Missing
Room unit 3 Missing In operation No recept'n Change batt	132	C	Missing
Outside sensor Missing In operation No recept'n Change batt	133	C	Missing
Repeater Missing In operation No recept'n Change batt	134	C	Missing
Operator unit 1 Missing In operation No recept'n Change batt	135	C	Missing
Operator unit 2 Missing In operation No recept'n Change batt	136	C	Missing
Operator unit 3 Missing In operation No recept'n Change batt	137	C	Missing
Service unit Missing In operation No recept'n Change batt	138	C	Missing
Delete all devices No Yes	140	C	No

(1) Parameter only visible, if wireless room device exists!

Time program	Heating circuit 1 Prog. no.	Heating circuit 2 ⁽¹⁾ Prog. no.	Heating circuit 3 Prog. no.	Level	Standard value
Preselection Mo - Su Mo - Su Mo - Fr Sa - Su Mo Tu Tu Th Fr Sa Su	500	520	540	Eu	Mo
1st phase on	501	521	541	Eu	06:00 (h/min)
1st phase off	502	522	542	Eu	22:00 (h/min)
2nd phase on	503	523	543	Eu	--:-- (h/min)
2nd phase off	504	524	544	Eu	--:-- (h/min)
3rd phase on	505	525	545	Eu	--:-- (h/min)
3rd phase off	506	526	546	Eu	--:-- (h/min)
Copy?	515	535	555	Eu	
Default values No Yes	516	536	556	Eu	No

(1) Parameter only visible if heating circuit exists!

Time program 4/DHW	Prog. no.	Level	Standard value
Preselection Mo - Su Mo - Su Mo - Fr Sa - Su Mo Tu Tu Th Fr Sa Su	560	Eu	Mo
1st phase on	561	Eu	05:00 (h/min)
1st phase off	562	Eu	22:00 (h/min)
2nd phase on	563	Eu	--:-- (h/min)
2nd phase off	564	Eu	--:-- (h/min)
3rd phase on	565	Eu	--:-- (h/min)
3rd phase off	566	Eu	--:-- (h/min)
Copy?	575	Eu	
Default values No Yes	576	Eu	No

Time program 5	Prog. no.	Level	Standard value
Preselection Mo - Su Mo - Su Mo - Fr Sa - Su Mo Tu Tu Th Fr Sa Su	600	Eu	Mo
1st phase on	601	Eu	06:00 (h/min)

Time program 5	Prog. no.	Level	Standard value
1st phase off	602	Eu	22:00 (h/min)
2nd phase on	603	Eu	--:-- (h/min)
2nd phase off	604	Eu	--:-- (h/min)
3rd phase on	605	Eu	--:-- (h/min)
3rd phase off	606	Eu	--:-- (h/min)
Copy?	615	Eu	
Default values No Yes	616	Eu	No

Holiday	Heating circuit 1 Prog. no.	Heating circuit 2 ⁽¹⁾ Prog. no.	Heating circuit 3 ⁽¹⁾ Prog. no.	Level	Standard value
Preselection Period 1 Period 2 Period 3 Period 4 Period 5 Period 6 Period 7 Period 8	641	651	661	Eu	Period 1
Start	642	652	662	Eu	—.— (day.month)
End	643	653	663	Eu	—.— (day.month)
Operating level Protection Reduced	648	658	668	Eu	Protection
(1) Parameter only visible if heating circuit exists!					

Heating circuit	1 Prog. no.	2 ⁽¹⁾ Prog. no.	3 ⁽¹⁾ Prog. no.	Level	Standard value
Operating mode Protection Automatic Reduced Comfort	700	1000	1300	Eu	Automatic
Comfort setpoint	710	1010	1310	Eu	20.0 °C
Reduced setpoint	712	1012	1312	Eu	18 °C
Frost protection setpoint	714	1014	1314	Eu	10.0 °C
Heating curve slope	720	1020	1320	Eu	1,24
Heating curve displacement	721	1021	1321	E	2.0 °C
Heating curve adaption 0: Off 1: On	726	1026	1326	E	Off
Summer/winter heating limit	730	1030	1330	Eu	20°C
24-hour heating limit	732	1032	1332	C	0 °C
Flow temp setpoint min	740	1040	1340	E	8 °C
Flow temp setpoint max	741	1041	1341	C	80 °C
Flow temp setpoint room stat	742	1042	1342	E	--- °C
Swi-on ratio room stat	744	1044	1344	E	--- %
Delay heat request	746	1046	1346	E	0 s
Room influence	750	1050	1350	C	--- %
Room temp limitation	760	1060	1360	E	0.5 °C
Boost heating	770	1070	1370	E	--- °C
Quick setback 0: Off 1: To Reduced setpoint 2: To Protection setpoint	780	1080	1380	C	1: To Reduced setpoint
Optimum start control max	790	1090	1390	E	0 (h:min)
Optimum stop control max	791	1091	1391	E	0 (h:min)
Reduced setp increase start	800	1100	1400	E	--- °C
Reduced setp increase end	801	1101	1401	E	-15 °C
Continuous pump operation 0: No 1: Yes	809	1109	1409	E	0: No
Overtemp prot pump circuit 0: Off 1: On	820	1120	1420	E	0: Off
Mixing valve boost	830	1130	1430	E	5 °C
Actuator running time	834	1134	1434	E	140 s

Heating circuit	1 Prog. no.	2 ⁽¹⁾ Prog. no.	3 ⁽¹⁾ Prog. no.	Level	Standard value
Floor curing function 0: Off 1: Functional heating 2: Curing heating 3: Functional/curing heating 4: Curing/functional heating 5: Manually	850	1150	1450	C	0: Off
Floor curing setp manually	851	1151	1451	C	25 °C
Floor curing setp current	855	1155	1455	C	--- °C
Floor curing day current	856	1156	1456	C	0
Excess heat draw 0: Off 1: Heating mode 2: Always	861	1161	1461	E	1: Heating mode
With buffer 0: No 1: Yes	870	1170	1470	E	1: Yes
With prim contr/system pump 0: No 1: Yes	872	1172	1472	E	1: Yes
Pump speed reduction 0: Operating level 1: Characteristic 2: Temp differential nominal	880	1180	1480	E	1: Characteristic
Pump speed min	882	1182	1482	C	40%
Pump speed max	883	1183	1483	C	100 %
Curve readj at 50% speed	888	1188	1488	E	10 %
Flow setp readj speed ctrl 0: No 1: Yes	890	1190	1490	E	1: Yes
Operating level changeover 0: Protection 1: Reduced 2: Comfort	898	1198	1498	E	1: Reduced
Optg mode changeover 0: None 1: Protection 2: Reduced 3: Comfort 4: Automatic	900	1200	1500	E	1: Protection
(1) Parameters only visible if heating circuit is installed!					

DHW	Prog. no.	Level	Standard value
Operating mode Off On	1600	Eu	On
Nominal setpoint	1610	Eu	55 °C
Reduced setpoint	1612	C	45 °C
Nominal setpoint max	1614	C	70 °C
Release 24h/day Time programs HCs Time program 4/DHW	1620	Eu	Time program 4/DHW
Charging priority 0: Absolute 1: Shifting 2: None 3: MC shifting, PC absolute	1630	C	3: MC shifting, PC absolute
Legionella function 0: Off 1: Periodically 2: Fixed weekday	1640	C	2: Fixed weekday
Legionella funct periodically	1641	C	3
Legionella funct weekday 1: Monday 2: Tuesday 3: Wednesday 4: Thursday 5: Friday 6: Saturday 7: Sunday	1642	C	7: Sunday
Legionella funct time	1644	C	--- (h:min)
Legionella funct setpoint	1645	C	65 °C
Legionella funct duration	1646	C	--- min
Legionella funct circ pump0: Off 1: On	1647	C	1: On
Circulating pump release 1: Time program 3/HCP 2: DHW release 3: Time program 4/DHW 4: Time program 5	1660	C	2: DHW release
Circulating pump cycling 0: Off 1: On	1661	C	1: On

DHW	Prog. no.	Level	Standard value
Circulation setpoint	1663	C	55 °C
Optg mode changeover 0: None 1: Off 2: On	1680	E	1: Off

Consumer circuit / swimming pool circuit	Consumer circuit 1 Prog. no.	Consumer circuit 2 Prog. no.	Swimming pool circuit Prog. no.	Level	Standard value
Flow temp setp cons request	1859	1909	1959	C	70 °C
DHW charging priority 0: No 1: Yes	1874	1924	1974	E	1: Yes
Excess heat draw 0: Off 1: On	1875	1925	1975	E	1: On
With buffer 0: No 1: Yes	1878	1928	1978	E	1: Yes
With prim contr/system pump 0: No 1: Yes	1880	1930	1980	E	1: Yes

Swimming pool	Prog. no.	Level	Standard value
Setpoint solar heating	2055	Eu	26 °C
Setpoint source heating	2056	Eu	22 °C
Charging priority solar 1: Priority 1 2: Priority 2 3: Priority 3	2065	E	3: Priority 3
Swimming pool temp max	2070	E	32 °C
With solar integration 0: No 1: Yes	2080	E	1: Yes

Primary contr/system pump	Prog. no.	Level	Standard value
Flow temp setpoint min	2110	E	8 °C
Flow temp setpoint max	2111	E	80 °C
Syst pump on heat gen lock 0: Off 1: On	2121	E	0: Off
Mixing valve boost	2130	E	0 °C
Actuator running time	2134	E	140 s
Primary contr/system pump 0: Before buffer 1: After buffer	2150	E	1: After buffer

Boiler	Prog. no.	Level	Standard value
Release below outside temp	2203	E	--- °C
Full charging buffer 0: Off 1: On	2208	E	0: Off
Setpoint min	2210	E	20 °C
Setpoint max	2212	E	90 °C
Setpoint manual control	2214	Eu	60 °C
Burner running time min	2241	E	1 min
Burner off time min	2243	E	3 min
SD burner off time	2245	E	20 °C
Pump overrun time	2250	E	2 min
Pump overr time after DHW	2253	E	5 min
Frost prot plant boiler pump 0: Off 1: On	2300	E	1: On
Boiler pump on heat gen lock 0: Off 1: On	2301	E	0: Off
Impact heat generation lock 1: Heating mode only 2: Heating and DHW mode	2305	E	1: Heating mode only
Temp differential max	2316	C	--- °C
Temp differential nominal	2317	C	15 °C

Boiler	Prog. no.	Level	Standard value
Pump modulation 0: None 1: Demand 2: Boiler setpoint 3: Temp differential nominal 4: Burner output	2320	E	3: Temp differential nominal
Pump speed min	2322	E	30%
Pump speed max	2323	E	100%
Output nominal	2330	E	EC five 400 kW: 400 kW EC five 470 kW: 470 kW EC five 540 kW: 540 kW EC five 610 kW: 610 kW
Output basic stage	2331	E	EC five 400 kW: 80 kW EC five 470 kW: 94 kW EC five 540 kW: 108 kW EC five 610 kW: 122 kW
Output at pump speed min	2334	E	10 %
Output at pump speed max	2335	E	90 %
Fan output heating max ⁽¹⁾	2441	E	EC five 400 kW: 400 kW EC five 470 kW: 470 kW EC five 540 kW: 540 kW EC five 610 kW: 610 kW
Fan output full charging max ⁽¹⁾	2442	E	EC five 400 kW: 400 kW EC five 470 kW: 470 kW EC five 540 kW: 540 kW EC five 610 kW: 610 kW
Fan output DHW max ⁽¹⁾	2444	E	EC five 400 kW: 400 kW EC five 470 kW: 470 kW EC five 540 kW: 540 kW EC five 610 kW: 610 kW
Controller delay 0: Off 1: Heating mode only 2: DHW mode only 3: Heating and DHW mode	2450	E	1: Heating mode only
Controller delay fan output ⁽¹⁾	2452	E	EC five 400 kW: 80 kW EC five 470 kW: 94 kW EC five 540 kW: 108 kW EC five 610 kW: 122 kW
Controller delay duration	2453	E	60 s
Switching diff on HCs	2454	E	4 °C
Switching diff off min HCs	2455	E	3 °C
Switching diff off max HCs	2456	E	5 °C

Boiler	Prog. no.	Level	Standard value
Switching diff on DHW	2460	E	4 °C
Switching diff off min DHW	2461	E	5 °C
Switching diff off max DHW	2462	E	7 °C
Delay heat req special op	2470	E	0 s
Static press superv sh'down 0: Start prevention 1: Lockout position	2480	E	0: Start prevention
Gas energy metering 0: Off 1: On	2550	C	0: Off
Gas energy metering correction	2551	C	1.0
Off delay flue gas damper	2560	E	30 s
(1) the kW settings are approximate values. Exact values can be determined by the gas meter for example.			

Cascade	Prog. no.	Level	Standard value
Lead strategy 1: Late on, early off 2: Late on, late off 3: Early on, late off	3510	E	2: Late on, late off
Release integral source seq	3530	E	50 °C*min
Reset integral source seq	3531	E	20 °C*min
Restart lock	3532	E	300 s
Switch on delay	3533	E	10 min
DHW switch-on delay	3535	E	2 min
Auto source seq ch'over	3540	E	100 h
Auto source seq exclusion 0: None 1: First 2: Last 3: First and last	3541	E	0: None
Leading source 1: Source 1 2: Source 2 3: Source 3 4: Source 4 5: Source 5 6: Source 6 7: Source 7 8: Source 8 9: Source 9 10: Source 10 11: Source 11 12: Source 12 13: Source 13 14: Source 14 15: Source 15 16: Source 16	3544	E	1: Source 1
Return setpoint min	3560	E	8 °C
Temp differential min	3590	E	--- °C

Solar	Prog. no.	Level	Standard value
Temp diff on	3810	C	8 °C
Temp diff off	3811	C	4 °C
Charg temp min DHW st tank	3812	E	--- °C
Temp diff on buffer	3813	C	--- °C
Temp diff off buffer	3814	C	--- °C
Charging temp min buffer	3815	C	--- °C
Temp diff on swi pool	3816	C	--- °C
Temp diff off swi pool	3817	C	--- °C
Charging temp min swi pool	3818	E	--- °C
Charging prio storage tank 0: None 1: DHW storage tank 2: Buffer storage tank	3822	E	1: DHW storage tank
Charging time relative prio	3825	E	--- min
Waiting time relative prio	3826	E	5 min
Waiting time parallel op	3827	E	--- min
Delay secondary pump	3828	E	60 s
Collector start function	3830	C	--- min
Min run time collector pump	3831	E	20 s
Collector start function on	3832	C	07:00 (h:min)
Collector start function off	3833	C	19:00 (h:min)
Collector start funct grad	3834	E	--- min/°C
Collector frost protection	3840	E	--- °C
Collector overtemp prot	3850	E	--- °C
Evaporation heat carrier	3860	E	130 °C

Solar	Prog. no.	Level	Standard value
Pump speed min	3870	E	10 %
Pump speed max	3871	E	100%
Antifreeze 1: None 2: Ethylene glycol 3: Propylene glycol 4: Ethyl and propyl glycol	3880	E	3: Propylene glycol
Antifreeze concentration	3881	E	50%
Pump capacity	3884	E	200 l/h
Pulse unit yield	3887	E	10 l



Solid fuel boiler	Prog. no.	Level	Standard value
Locks other heat sources 0: Off 1: On	4102	E	0: Off
Setpoint min	4110	E	65 °C
Temp diff on	4130	E	8 °C
Temp diff off	4131	E	4 °C
Comparative temp 1: DHW sensor B3 2: DHW sensor B31 3: Buffer sensor B4 4: Buffer sensor B41 5: Flow temp setpoint 6: Setpoint min	4133	E	Buffer sensor B41
Pump overrun time	4140	E	20 min

Buffer storage tank	Prog. no.	Level	Standard value
Auto generation lock 0: None 1: With B4 2: With B4 and B42/B41	4720	E	1: With B4
Auto heat gen lock SD	4721	E	5 °C
Temp diff buffer/HC	4722	E	-3 °C
Min st tank temp heat mode	4724	E	--- °C
Charging temp max	4750	E	80 °C
Recooling temp	4755	E	60 °C
Recooling DHW/HCs 0: Off 1: On	4756	E	0: Off
Recooling collector 0: Off 1: Summer 2: Always	4757	E	0: Off
With solar integration 0: No 1: Yes	4783	E	1: Yes
Temp diff on return div	4790	E	8 °C
Temp diff off return div	4791	E	4 °C
Compar temp return div 1: With B4 2: With B41 3: With B42	4795	E	1: With B4
Optg action return diversion 1: Temp decrease 2: Temp increase	4796	E	2: Temp increase
Partial charging setpoint	4800	E	--- °C
Full charging 0: Off 1: Heating mode 2: Always	4810	E	0: Off
Full charging temp min	4811	E	8 °C
Full charging sensor 1: With B4 2: With B42/B41	4813	E	2: With B42/B41

DHW storage tank ⁽¹⁾	Prog. no.	Level	Standard value
Forward shift charging	5011	E	01:00 (h:min)
Flow setpoint boost	5020	E	18 °C
Transfer boost	5021	E	10 °C
Type of charging 1: Recharging 2: Full charging 3: Full charging legio 4: Full charg 1st time day 5: Full charg 1st time legio	5022	C	2: Full charging
Switching diff	5024	E	4 °C
Charging time limitation	5030	E	120 min

DHW storage tank ⁽¹⁾	Prog. no.	Level	Standard value
Discharging protection 0: Off 1: Always 2: Automatically	5040	E	2: Automatically
Discharg protec after charg 0: Off 1: On	5042	E	0: Off
Charging temp max	5050	E	69 °C
Recooling temp	5055	E	80 °C
Recooling collector 0: Off 1: Summer 2: Always	5057	E	0: Off
El imm heater optg mode 1: Substitute 2: Summer 3: Always	5060	E	1: Substitute
El immersion heater release 1: 24h/day 2: DHW release 3: Time program 4/DHW	5061	E	2: DHW release
El immersion heater control 1: External thermostat 2: DHW sensor	5062	E	2: DHW sensor
Automatic push 0: Off 1: On	5070	E	1: On
Excess heat draw 0: Off 1: On	5085	E	1: On
With buffer 0: No 1: Yes	5090	E	1: Yes
With prim contr/system pump 0: No 1: Yes	5092	E	1: Yes
With solar integration 0: No 1: Yes	5093	E	1: Yes
Pump speed min	5101	E	0%
Pump speed max	5102	E	100%
Speed Xp	5103	E	15 °C
Speed Tn	5104	E	60 s
Speed Tv	5105	E	5 s
Transfer strategy 0: Off 1: Always 2: DHW release	5130	E	1: Always
Interm circ boost recharging	5139	E	5 °C
Intermediate circuit boost	5140	E	2 °C
Excess interm circ temp max	5141	E	2 °C
Flow setp compensation delay	5142	E	30 s
Flow setp compensation Xp	5143	E	50 °C
Flow setp compensation Tn	5144	E	30 s
Flow setp compensation Tv	5145	E	30 s
Full charging with B36 0: No 1: Yes	5146	E	0: No
Min start temp diff Q33	5148	E	-3 °C
Excess interm circ temp del	5151	E	30 s
(1) Parameters depend on the hydraulic System!			

Configuration	Prog. no.	Level	Standard value
Heating circuit 1 0: Off 1: On	5710	C	1: On
Heating circuit 2 0: Off 1: On	5715	C	0: Off
Heating circuit 3 0: Off 1: On	5721	C	0: Off
DHW sensor 1: DHW sensor B3 2: Thermostat	5730	E	1: DHW sensor B3
DHW ctrl elem Q3 0: No charging request 1: Charging pump 2: Diverting valve	5731	E	1: Charging pump

Configuration	Prog. no.	Level	Standard value
Basic position DHW div valve 0: Last request 1: Heating circuit 2: DHW	5734	E	1: Heating circuit
DHW separate circuit 0: Off 1: On	5736	E	0: Off
Optg action DHW div valve 0: Position on DHW 1: Position on heating circuit	5737	E	0: Position on DHW
Ctrl boiler pump/DHW valve 0: All requests 1: Request HC1/DHW only	5774	E	0: All requests
Boiler pump at DHW 0: Off 1: On	5775	E	1: On
Solar controlling element 1: Charging pump 2: Diverting valve	5840	E	2: Diverting valve
External solar exchanger 1: Jointly 2: DHW storage tank 3: Buffer storage tank	5841	E	1: Jointly
Combi storage tank 0: No 1: Yes	5870	E	0: No
Relay output QX1 0: None 1: Circulating pump Q4 2: El imm heater DHW K6 3: Collector pump Q5 4: Cons circuit pump VK1 Q15 5: Boiler pump Q1 7: Alarm output K10 11: Heat circuit pump HC3 Q20 12: Cons circuit pump VK2 Q18 13: System pump Q14 14: Heat gen shutoff valve Y4 15: Solid fuel boiler pump Q10 16: Time program 5 K13 17: Buffer return valve Y15 18: Solar pump ext exch K9 19: Solar ctrl elem buffer K8 20: Solar ctrl elem swi pool K18 22: Swimming pool pump Q19 25: Cascade pump Q25 26: St tank transfer pump Q11 27: DHW mixing pump Q35 28: DHW interm circ pump Q33 29: Heat request K27 33: Heat circuit pump HC1 Q2 34: Heat circuit pump HC2 Q6 35: DHW ctrl elem Q3 40: Status output K35 41: Status information K36 42: Flue gas damper K37 43: Fan shutdown K38	5890	C	7: Alarm output K10
Relay output QX2  See Parameters see Relay output QX1 (prog. no. 5890)!	5891	C	33: Heat circuit pump HC1 Q2
Relay output QX3  See Parameters see Relay output QX1 (prog. no. 5890)!	5892	C	35: DHW ctrl elem Q3
Sensor input BX1 0: None 1: DHW sensor B31 2: Collector sensor B6 4: DHW circulation sensor B39 5: Buffer sensor B4 6: Buffer sensor B41 8: Common flow sensor B10 9: Solid fuel boiler sensor B22 10: DHW charging sensor B36 11: Buffer sensor B42 12: Common return sensor B73 13: Cascade return sensor B70 14: Swimming pool sensor B13 16: Solar flow sensor B63 17: Solar return sensor B64	5930	C	2: Collector sensor B6
Sensor input BX2  See Parameters see Sensor input BX1 (prog. no. 5930)!	5931	C	1: DHW sensor B31
Function input H1 0: None 1: Optg mode change HCs+DHW 2: Optg mode changeover DHW 3: Optg mode changeover HCs 4: Optg mode changeover HC1 5: Optg mode changeover HC2 6: Optg mode changeover HC3 7: Heat generation lock 8: Error/alarm message 9: Consumer request VK1 10: Consumer request VK2 11: Release swi pool source heat 12: Excess heat discharge 13: Release swi pool solar 14: Operating level DHW 15: Operating level HC1 16: Operating level HC2 17: Operating level HC3 18: Room thermostat HC1 19: Room thermostat HC2 20: Room thermostat HC3 22: DHW thermostat 24: Pulse count 28: Checkb sign flue gas damper 29: Start prevention 51: Consumer request VK1 10V 52: Consumer request VK2 10V 58: Output request 10V 60: Temp measurement 10V	5950	C	0: None

Configuration	Prog. no.	Level	Standard value
Contact type H1 0: NC 1: NO	5951	C	1: NO
Voltage value 1 H1	5953	E	0 V
Function value 1 H1	5954	E	0
Voltage value 2 H1	5955	E	10 V
Function value 2 H1	5956	E	1000
Function input H4 0: None 1: Optg mode change HCs+DHW 2: Optg mode changeover DHW 3: Optg mode changeover HCs 4: Optg mode changeover HC1 5: Optg mode changeover HC2 6: Optg mode changeover HC3 7: Heat generation lock 8: Error/alarm message 9: Consumer request VK1 10: Consumer request VK2 11: Release swi pool source heat 12: Excess heat discharge 13: Release swi pool solar 14: Operating level DHW 15: Operating level HC1 16: Operating level HC2 17: Operating level HC3 18: Room thermostat HC1 19: Room thermostat HC2 20: Room thermostat HC3 22: DHW thermostat 24: Pulse count 28: Checkb sign flue gas damper 29: Start prevention 50: Flow measurement Hz	5970	C	0: None
Contact type H4 0: NC 1: NO	5971	C	1: NO
Frequency value 1 H4	5973	E	0
Function value 1 H4	5974	E	0
Frequency value 2 H4	5975	E	0
Function value 2 H4	5976	E	0
Function input H5 0: None 1: Optg mode change HCs+DHW 2: Optg mode changeover DHW 3: Optg mode changeover HCs 4: Optg mode changeover HC1 5: Optg mode changeover HC2 6: Optg mode changeover HC3 7: Heat generation lock 8: Error/alarm message 9: Consumer request VK1 10: Consumer request VK2 11: Release swi pool source heat 12: Excess heat discharge 13: Release swi pool solar 14: Operating level DHW 15: Operating level HC1 16: Operating level HC2 17: Operating level HC3 18: Room thermostat HC1 19: Room thermostat HC2 20: Room thermostat HC3 22: DHW thermostat 24: Pulse count 28: Checkb sign flue gas damper 29: Start prevention	5977	C	0: None
Contact type H5 0: NC 1: NO	5978	C	1: NO
Function output P1 0: None 1: Boiler pump Q1 2: DHW pump Q3 3: DHW interm circ pump Q33 4: Heat circuit pump HC1 Q2 5: Heat circuit pump HC2 Q6 6: Heat circuit pump HC3 Q20 7: Collector pump Q5 8: Solar pump ext exch K9 9: Solar pump buffer K8 10: Solar pump swi pool K18	6085	E	0: None
Signal logic output P1 0: Standard 1: Inverted	6086	E	1: Inverted
Sensor type collector 1: NTC 2: Pt 1000	6097	E	1: NTC
Readjustm collector sensor	6098	E	0 °C
Readjustm outside sensor	6100	E	0 °C
Time constant building	6110	C	10 h
Central setp compensation	6117	E	10 °C
Frost protection plant 0: Off 1: On	6120	E	1: On
Water pressure min	6181	E	0.7 bars
Save sensors 0: No 1: Yes	6200	C	0: No
Reset to default parameters 0: No 1: Yes	6205	C	0: No
Check no. heat source 1	6212	E	
Check no. heat source 2	6213	E	
Check no. storage tank	6215	E	

Configuration	Prog. no.	Level	Standard value
Check no. heating circuits	6217	E	
Software version	6220	E	
Info 1 OEM	6230	E	
Info 2 OEM	6231	E	
Parameter set number OEM	6236	E	
Info 3 OEM	6258	E	
Info 4 OEM	6259	E	

LPB system	Prog. no.	Level	Standard value
Device address	6600	C	1
Segment address	6601	E	0
Bus power supply function 0: Off 1: Automatically	6604	E	1: Automatically
Bus power supply state 0: Off 1: On	6605	E	
Display system messages 0: No 1: Yes	6610	E	1: Yes
System message to alarm relay 0: No 1: Yes	6611	E	1: Yes
Alarm delay	6612	C	- - - min
Action changeover functions 0: Segment 1: System	6620	E	1: System
Summer changeover 0: Locally 1: Centrally	6621	E	0: Locally
Optg mode changeover 0: Locally 1: Centrally	6623	E	1: Centrally
Manual source lock 0: Locally 1: Segment	6624	E	0: Locally
DHW assignment 0: Local HCs 1: All HCs in segment 2: All HCs in system	6625	E	2: All HCs in system
Note OT limit ext source 0: No 1: Yes	6632	E	0: No
Clock mode 0: Autonomously 1: Slave without remote setting 2: Slave with remote setting 3: Master	6640	C	2: Slave with remote setting
Outside temp source	6650	E	



Modbus	Prog. no.	Level	Standard value
Slave address	6651	E	- - -
Baud rate 0: 1'200 1: 2'400 2: 4'800 3: 9'600 4: 19'200	6652	E	4: 19'200
Parity 0: Even 1: Odd 2: None	6653	E	0: Even
Stop bit	6654	E	1







Error	Prog. no.	Level	Standard value
Message	6700	Eu	
SW diagnostic code	6705	Eu	
Burn ctrl phase lockout pos	6706	Eu	
Reset alarm relay 0: No 1: Yes	6710	C	0: No
Flow temp 1 alarm	6740	E	- - - min
Flow temp 2 alarm	6741	E	- - - min
Flow temp 3 alarm	6742	E	- - - min
Boiler temp alarm	6743	E	- - - min
DHW charging alarm	6745	E	- - - h









Error	Prog. no.	Level	Standard value
History 1 • Date / Time • Fault code 1	6800	C	
SW diagnostic code 1 • Burner control phase 1	6805	C	
History 2 • Date / Time • Fault code 2	6810	C	
SW diagnostic code 2 • Burner control phase 2	6815	C	
History 3 • Date / Time • Fault code 3	6820	E	
SW diagnostic code 3 • Burner control phase 3	6825	C	
.	.	.	
.	.	.	
.	.	.	
History 20 • Date / Time • Fault code 20	6990	C	
SW diagnostic code 20 • Burner control phase 20	6995	C	



Service/special operation	Prog. no.	Level	Standard value
Burner hours interval	7040	C	--- h
Burn hrs since maintenance	7041	C	(h)
Burner start interval	7042	C	---
Burn starts since maint	7043	C	
Maintenance interval	7044	C	--- months
Time since maintenance	7045	C	(month)
Fan speed ionization current	7050	E	--- U/min
Message ionization current 0: No 1: Yes	7051	E	0: No
Chimney sweep function Off On	7130	Eu	Off
Manual control Off On	7140	Eu	Off
Controller stop function 0: Off 1: On	7143	E	0: Off
Controller stop setpoint	7145	E	100%
Forced heat draw DHW 0: Off 1: On	7165	E	0: Off
Commissioning wizard 0: Off 1: On	7167	E	0: Off
Telephone customer service	7170	C	0
PStick storage pos PStick Reg data set	7250	E	0

Service/special operation	Prog. no.	Level	Standard value
PStick command 0: No operation 1: Reading from stick 2: Writing on stick	7252	E	0: No operation
PStick progress PStick status 0: No stick 1: Stick ready 2: Writing on stick 3: Reading from stick 4: EMC test active 5: Writing error 6: Reading error 7: Incompatible data set 8: Wrong stick type 9: Stick format error 10: Check data set 11: Data set disabled 12: Reading disabled	7253	E	0% 0: No stick

Config extension module	Prog. no.	Level	Standard value
Function extension module 1 0: None 1: Multifunctional 2: Heating circuit 1 3: Heating circuit 2 4: Heating circuit 3 6: Solar DHW 7: Primary contr/system pump	7300	C	3: Heating circuit 2
Relay output QX21 module 1 0: None 1: Circulating pump Q4 2: El imm heater DHW K6 3: Collector pump Q5 4: Cons circuit pump VK1 Q15 5: Boiler pump Q1 7: Alarm output K10 11: Heat circuit pump HC3 Q20 12: Cons circuit pump VK2 Q18 13: System pump Q14 14: Heat gen shutoff valve Y4 15: Solid fuel boiler pump Q10 16: Time program 5 K13 17: Buffer return valve Y15 18: Solar pump ext exch K9 19: Solar ctrl elem buffer K8 20: Solar ctrl elem swi pool K18 22: Swimming pool pump Q19 25: Cascade pump Q25 26: St tank transfer pump Q11 27: DHW mixing pump Q35 28: DHW interm circ pump Q33 29: Heat request K27 33: Heat circuit pump HC1 Q2 34: Heat circuit pump HC2 Q6 35: DHW ctrl elem Q3 40: Status output K35 41: Status information K36 43: Fan shutdown K38	7301	C	0: None
Relay output QX22 module 1  See Parameters see Relay output QX21 module 1 (prog. no. 7301)!	7302	C	0: None
Relay output QX23 module 1  See Parameters see Relay output QX21 module 1 (prog. no. 7301)!	7303	C	0: None
Sensor input BX21 module 1 0: None 1: DHW sensor B31 2: Collector sensor B6 4: DHW circulation sensor B39 5: Buffer sensor B4 6: Buffer sensor B41 8: Common flow sensor B10 9: Solid fuel boiler sensor B22 10: DHW charging sensor B36 11: Buffer sensor B42 12: Common return sensor B73 13: Cascade return sensor B70 14: Swimming pool sensor B13 16: Solar flow sensor B63 17: Solar return sensor B64	7307	C	0: None
Sensor input BX22 module 1  See Parameters see Sensor input BX21 module 1 (prog. no. 7307)!	7308	C	0: None
Function input H2/H21 module 1 0:None 1: Optg mode change HCs+DHW 2: Optg mode changeover DHW 3: Optg mode changeover HCs 4: Optg mode changeover HC1 5: Optg mode changeover HC2 6: Optg mode changeover HC3 7: Heat generation lock 8: Error/alarm message 9: Consumer request VK1 10: Consumer request VK2 11: Release swi pool source heat 12: Excess heat discharge 13: Release swi pool solar 14: Operating level DHW 15: Operating level HC1 16: Operating level HC2 17: Operating level HC3 18: Room thermostat HC1 19: Room thermostat HC2 20: Room thermostat HC3 22: DHW thermostat 25: Limit thermostat HC 29: Start prevention 51: Consumer request VK1 10V 52: Consumer request VK2 10V 58: Output request 10V	7321	C	0:None
Contact type H2/H21 module 1 0: NC 1: NO	7322	C	1: NO
Input value 1 H2/H21 module 1	7324	C	0 V
Funct value 1 H2/H21 module 1	7325	C	0

Config extension module	Prog. no.	Level	Standard value
Input value 2 H2/H21 module 1	7326	C	10 V
Funct value 2 H2/H21 module 1	7327	C	1000
Funct input EX21 module 1 0: None 25: Limit thermostat HC	7342	C	0: None
Funct output UX21 module 1 0: None 1: Boiler pump Q1 2: DHW pump Q3 3: DHW interm circ pump Q33 4: Heat circuit pump HC1 Q2 5: Heat circuit pump HC2 Q6 6: Heat circuit pump HC3 Q20 7: Collector pump Q5 8: Solar pump ext exch K9 9: Solar ctrl elem buffer K8 10: Solar ctrl elem swi pool K18	7348	C	0: None
Sign logic out UX21 module1 0: Standard 1: Inverted	7349	C	0: Standard
Signal output UX21 module 1 0: 0..10V 1: PWM	7350	C	1: PWM
Funct output UX22 module 1  See Parameters see Funct output UX21 module 1 (prog. no. 7348)!	7355	C	0: None
Sign logic out UX22 module1 0: Standard 1: Inverted	7356	C	0: Standard
Signal output UX22 module 1 0: 0..10V 1: PWM	7357	C	1: PWM
Function extension module 2 0: None 1: Multifunctional 2: Heating circuit 1 3: Heating circuit 2 4: Heating circuit 3 6: Solar DHW 7: Primary contr/system pump	7375	C	4: Heating circuit 3
Relay output QX21 module 2 0: None 1: Circulating pump Q4 2: El imm heater DHW K6 3: Collector pump Q5 4: Cons circuit pump VK1 Q15 5: Boiler pump Q1 7: Alarm output K10 11: Heat circuit pump HC3 Q20 12: Cons circuit pump VK2 Q18 13: System pump Q14 14: Heat gen shutoff valve Y4 15: Solid fuel boiler pump Q10 16: Time program 5 K13 17: Buffer return valve Y15 18: Solar pump ext exch K9 19: Solar ctrl elem buffer K8 20: Solar ctrl elem swi pool K18 22: Swimming pool pump Q19 25: Cascade pump Q25 26: St tank transfer pump Q11 27: DHW mixing pump Q35 28: DHW interm circ pump Q33 29: Heat request K27 33: Heat circuit pump HC1 Q2 34: Heat circuit pump HC2 Q6 35: DHW ctrl elem Q3 40: Status output K35 41: Status information K36 43: Fan shutdown K38	7376	C	0: None
Relay output QX22 module 2  See Parameters see Relay output QX21 module 2 (prog. no. 7376)!	7377	C	0: None
Relay output QX23 module 2  See Parameters see Relay output QX21 module 2 (prog. no. 7376)!	7378	C	0: None
Sensor input BX21 module 2  See Parameters see Sensor input BX21 module 1 (prog. no. 7307)!	7382	C	0: None
Sensor input BX22 module 2  See Parameters see Sensor input BX21 module 1 (prog. no. 7307)!	7383	C	0: None
Function input H2/H21 module 2  See Parameters see Function input H2/H21 module 1 (prog. no. 7321)!	7396	C	0: None



Config extension module	Prog. no.	Level	Standard value
Contact type H2/H21 module 2 0: NC 1: NO	7397	C	1: NO
Input value 1 H2/H21 module 2	7399	C	0 V
Funct value 1 H2/H21 module 2	7400	C	0
Input value 2 H2/H21 module 2	7401	C	10 V
Funct value 2 H2/H21 module 2	7402	C	1000
Funct input EX21 module 2 0: None 25: Limit thermostat HC	7417	C	0: None
Funct output UX21 module 2  See Parameters see Funct output UX21 module 1 (prog. no. 7348)!	7423	C	0: None
Sign logic out UX21 module 2 0: Standard 1: Inverted	7424	C	0: Standard
Signal output UX21 module 2 0: 0..10V 1: PWM	7425	C	1: PWM
Funct output UX22 module 2  See Parameters see Funct output UX21 module 1 (prog. no. 7348)!	7430	C	0: None
Sign logic out UX22 module 2 0: Standard 1: Inverted	7431	C	0: Standard
Signal output UX22 module 2 0: 0..10V 1: PWM	7432	C	1: PWM
Function extension module 3 0: None 1: Multifunctional 2: Heating circuit 1 3: Heating circuit 2 4: Heating circuit 3 6: Solar DHW 7: Primary contr/system pump	7450	C	0: None
Relay output QX21 module 3  See Parameters see Relay output QX21 module 1 (prog. no. 7301)!	7451	C	0: None
Relay output QX22 module 3  See Parameters see Relay output QX21 module 1 (prog. no. 7301)!	7452	C	0: None
Relay output QX23 module 3  See Parameters see Relay output QX21 module 1 (prog. no. 7301)!	7453	C	0: None
Sensor input BX21 module 3  See Parameters see Sensor input BX21 module 1 (prog. no. 7307)!	7457	C	0: None
Sensor input BX22 module 3  See Parameters see Sensor input BX21 module 1 (prog. no. 7307)!	7458	C	0: None
Function input H2/H21 module 3  See Parameters see Function input H2/H21 module 1 (prog. no. 7321)!	7471	C	0: None
Contact type H2/H21 module 3 0: NC 1: NO	7472	C	1: NO
Input value 1 H2/H21 module 3	7474	C	0 V
Funct value 1 H2/H21 module 3	7475	C	0

Config extension module	Prog. no.	Level	Standard value
Input value 2 H2/H21 module 3	7476	C	10 V
Funct value 2 H2/H21 module 3	7477	C	1000
Funct input EX21 module 3	7492	C	0: None
 See Parameters see Funct output UX21 module 1 (prog. no. 7342)!			
Funct output UX21 module 3	7498	C	0: None
 See Parameters see Funct output UX21 module 1 (prog. no. 7348)!			
Sign logic out UX21 module3 0: Standard 1: Inverted	7499	C	0: Standard
Signal output UX21 module 3 0: 0..10V 1: PWM	7500	C	1: PWM
Funct output UX22 module 3	7505	C	0: None
 See Parameters see Funct output UX21 module 1 (prog. no. 7348)!			
Sign logic out UX22 module3 0: Standard 1: Inverted	7506	C	0: Standard
Signal output UX22 module 3 0: 0..10V 1: PWM	7507	C	1: PWM

Input/output test	Prog. no.	Level	Standard value
Relay test 0: No test 1: Everything off 2: Relay output QX1 3: Relay output QX2 4: Relay output QX3 6: Relay output QX21 module 1 7: Relay output QX22 module 1 8: Relay output QX23 module 1 9: Relay output QX21 module 2 10: Relay output QX22 module 2 11: Relay output QX23 module 2 12: Relay output QX21 module 3 13: Relay output QX22 module 3 14: Relay output QX23 module 3	7700	C	0: No test
Output test P1	7713	C	
PWM signal P1	7714	C	
Outside temp B9	7730	C	
DHW temp B3/B38	7750	C	
Boiler temp B2	7760	C	
Output test UX21 module 1	7780	C	
Output signal UX21 module 1	7781	C	
Output test UX22 module 1	7782	C	
Output signal UX22 module 1	7783	C	
Output test UX21 module 2	7784	C	
Output signal UX21 module 2	7785	C	
Output test UX22 module 2	7786	C	
Output signal UX22 module 2	7787	C	
Output test UX21 module 3	7788	C	
Output signal UX21 module 3	7789	C	
Output test UX22 module 3	7790	C	
Output signal UX22 module 3	7791	C	
Sensor temp BX1	7820	C	
Sensor temp BX2	7821	C	
Sensor temp BX3	7822	C	
Sensor temp BX21 module 1	7830	C	
Sensor temp BX22 module 1	7831	C	
Sensor temp BX21 module 2	7832	C	
Sensor temp BX22 module 2	7833	C	

Input/output test	Prog. no.	Level	Standard value
Sensor temp BX21 module 3	7834	C	
Sensor temp BX22 module 3	7835	C	
Voltage signal H1	7840	C	
Contact state H1 0: Open 1: Closed	7841	C	
Voltage signal H2/H21 module 1	7845	C	
Contact state H2/H21 module 1 0: Open 1: Closed	7845	C	
Voltage signal H2/H21 module 2	7848	C	
Contact state H2/H21 module 2 0: Open 1: Closed	7848	C	
Voltage signal H2/H21 module 3	7851	C	
Contact state H2/H21 module 3 0: Open 1: Closed	7851	C	
Contact state H4 0: Open 1: Closed	7860	C	
Frequency H4	7862	C	
Contact state H5 0: Open 1: Closed	7865	C	
Contact state H6 0: Open 1: Closed	7872	C	
Contact state H7 0: Open 1: Closed	1874	C	
Input EX21 module 1 0: 0V 230V	7950	C	
Input EX21 module 2 0: 0V 230V	7951	C	
Input EX21 module 3 0: 0V 230V	7952	C	

State	Prog. no.	Level	Standard value
State heating circuit 1	8000	C	
State heating circuit 2	8001	C	
State heating circuit 3	8002	C	
State DHW	8003	C	
State boiler	8005	C	
State solar	8007	C	
State solid fuel boiler	8008	C	
State burner	8009	C	
State buffer	8010	C	
State swimming pool	8011	C	

Diagnostics cascade	Prog. no.	Level	Standard value
Priority/state source 1 0: Missing 1: Faulty 2: Manual control active 3: Heat generation lock active 4: Chimney sweep funct active 5: Temporarily unavailable 6: Outside temp limit active 7: Not released 8: Released	8100	C	
Priority/state source 2  See Parameters see Priority/state source 1 (prog. no. 8100)!	8102	C	
Priority/state source 3  See Parameters see Priority/state source 1 (prog. no. 8100)!	8104	C	
.	.	.	

Diagnosics cascade	Prog. no.	Level	Standard value
.	.	.	
.	.	.	
Priority/state source 16	8130	C	
 See Parameters see Priority/state source 1 (prog. no. 8100)!			
Cascade flow temp	8138	C	
Cascade flow temp setp	8139	C	
Cascade return temp	8140	C	
Cascade return temp setp	8141	C	
Source seq ch'over current	8150	C	

Diagnosics heat generation	Prog. no.	Level	Standard value
Boiler pump Q1	8304	E	
Boiler pump speed	8308	E	
Boiler temp Control temperature	8310	C	
Boiler setpoint Control setpoint	8311	C	
Boiler switching point	8312	C	
Control sensor 0: None 1: Boiler sensor B2 2: Return sensor B7 3: DHW charging sensor B36 4: DHW outlet sensor B38 5: DHW circulation sensor B39 6: Cascade sensor B10/B70	8313	E	
Boiler return temp	8314	C	
Fan speed	8323	C	
Set point fan	8324	C	
Current fan control	8325	C	
Burner modulation	8326	C	
Ionization current	8329	C	
Hours run 1st stage Start counter 1st stage	8330	Eu C	
Hours run heating mode	8338	Eu	
Hours run DHW	8339	Eu	
Total gas energy heating	8378	Eu	
Total gas energy DHW	8379	Eu	
Total gas energy	8380	Eu	
Gas energy heating ⁽¹⁾	8381	Eu	
Gas energy DHW ⁽¹⁾	8382	Eu	
Gas energy	8383	Eu	
Current phase number	8390	E	
Collector pump 1 0: Off 1: On	8499	C	
Solar ctrl elem buffer 0: Off 1: On	8501	E	
Solar ctrl elem swi pool 0: Off 1: On	8502	E	
Speed collector pump 1	8505	E	
Speed solar pump ext exch	8506	E	
Speed solar pump buffer	8507	E	
Speed solar pump swi pool	8508	E	
Collector temp 1	8510	C	
Collector temp 1 max	8511	C	
Collector temp 1 min	8512	C	

Diagnostics heat generation	Prog. no.	Level	Standard value
dt collector 1/DHW	8513	C	
dt collector 1/buffer	8514	C	
dt collector 1/swimming pool	8515	C	
Solar flow temp	8519	E	
Solar return temp	8520	E	
24-hour yield solar energy	8526	Eu	
Total yield solar energy	8527	Eu	
Hours run solar yield	8530	Eu	
Hours run collect overtemp	8531	E	
Hours run collector pump	8532	Eu	
Solid fuel boiler temp	8560	C	
Hours run solid fuel boiler	8570	C	
(1) Dieser Parameter kann zurückgesetzt werden.			

Diagnostics consumers	Prog. no.	Level	Standard value
Outside temp	8700	Eu	
Outside temp min	8701	Eu	
Outside temp max	8702	Eu	
Outside temp attenuated	8703	E	
Outside temp composite	8704	E	
Heating circuit pump 1 0: Off 1: On	8730	C	
Heat circ mix valve 1 open Off On	8731	C	
Heat circ mix valve 1 close 0: Off 1: On	8732	C	
Speed heating circuit pump 1	8735	C	
Room temp 1 Room setpoint 1	8740	C	
Flow temp 1 Flow temp setpoint 1	8743	C	
Room thermostat 1 0: No demand 1: Demand	8749	C	
Heating circuit pump 2 0: Off 1: On	8760	C	
Heat circ mix valve 2 open 0: Off 1: On	8761	C	
Heat circ mix valve 2 close 0: Off 1: On	8762	C	
Speed heating circuit pump 2	8765	C	
Room temp 2 Room setpoint 2	8770	C	
Flow temp 2 Flow temp setpoint 2	8773	C	
Room thermostat 2 0: No demand 1: Demand	8779	C	
Heating circuit pump 3 0: Off 1: On	8790	C	
HC mixing valve 3 open 0: Off 1: On	8791	C	
HC mixing valve 3 closed 0: Off 1: On	8792	C	
Speed heating circuit pump 3	8795	C	
Room temp 3 Room setpoint 3	8800	C	

Diagnosics consumers	Prog. no.	Level	Standard value
Flow temp 3 Flow temp setpoint 3	8804	C	
Room thermostat 3 0: No demand 1: Demand	8809	C	
DHW pump 0: Off 1: On	8820	C	
DHW interm circ pump Q33 Off On	8823	E	
Speed DHW pump	8825	E	
Speed DHW interm circ pump	8826	E	
DHW temp 1 DHW temp setpoint	8830	C	
DHW temp 2	8832	C	
DHW circulation temp	8835	E	
DHW charging temp	8836	E	
Flow temp setp VK1	8875	C	
Flow temp setp VK2	8885	C	
Flow temp setp VK3	8895	C	
Swimming pool temp Swimming pool setpoint	8900	C	
Primary controller temp Primary controller setpoint	8930	E	
Common flow temp Common flow temp setpoint	8950	E	
Common return temp	8952	E	
Common output setpoint	8962	E	
Buffer temp 1	8980	C	
Buffer setpoint	8981	C	
Buffer temp 2	8982	C	
Buffer temp 3	8983	C	
Water pressure	9009	C	
Relay output QX1 0: Off 1: On	9031	C	
Relay output QX2 0: Off 1: On	9032	C	
Relay output QX3 0: Off 1: On	9033	C	
Relay output QX21 module 1 0: Off 1: On	9050	C	
Relay output QX22 module 1 0: Off 1: On	9051	C	
Relay output QX23 module 1 0: Off 1: On	9052	C	
Relay output QX21 module 2 0: Off 1: On	9053	C	
Relay output QX22 module 2 0: Off 1: On	9054	C	
Relay output QX23 module 2 0: Off 1: On	9055	C	
Relay output QX21 module 3 0: Off 1: On	9056	C	
Relay output QX22 module 3 0: Off 1: On	9057	C	
Relay output QX23 module 3 0: Off 1: On	9058	C	

Burner control	Prog. no.	Level	Standard value
Prepurge time	9500	E	20 s
Required output prepurging ⁽¹⁾	9504	E	EC five 400 kW: 338 kW EC five 470 kW: 362 kW EC five 540 kW: 364 kW EC five 610 kW: 343 kW
Required output ignition ⁽¹⁾	9512	E	EC five 400 kW: 129 kW EC five 470 kW: 148 kW EC five 540 kW: 148 kW EC five 610 kW: 169 kW
Required output LF ⁽¹⁾	9524	E	EC five 400 kW: 80 kW EC five 470 kW: 94 kW EC five 540 kW: 108 kW EC five 610 kW: 122 kW
Required output HF ⁽¹⁾	9529	E	EC five 400 kW: 400 kW EC five 470 kW: 470 kW EC five 540 kW: 540 kW EC five 610 kW: 610 kW
Postpurge time	9540	E	20 s
Fan output/speed slope	9626	E	EC five 400 kW: 8.10 EC five 470 kW: 7.45 EC five 540 kW: 7.41 EC five 610 kW: 6.35
Fan output/speed Y-section	9627	E	EC five 400 kW: 250 EC five 470 kW: 300 EC five 540 kW: 300 EC five 610 kW: 325
(1) the kW settings are approximate values. Exact values can be determined by the gas meter for example.			

Info ⁽¹⁾	Prog. no.	Level	Standard value
Error			
Maintenance			
Setpoint manual control			
Floor curing setp current			
Floor curing day current			
Room temp 1			
Room temperature min			
Room temperature max			
Cascade flow temp			
Boiler temp			
Outside temp			
DHW temp 1			
DHW consumption temp			
Collector temp 1			

Info ⁽¹⁾	Prog. no.	Level	Standard value
24-hour yield solar energy			
Total yield solar energy			
Solid fuel boiler temp			
Buffer temp 1			
Swim pool temp			
State heating circuit 1			
State heating circuit 2			
State heating circuit 3			
State DHW			
State boiler			
State solar			
State solid fuel boiler			
State buffer			
State swimming pool			
Year			
Date			
Time			
Telephone customer service			
Water pressure			

(1) The display of the information values depends on the operation state!

9.2 Description of the parameters

9.2.1 Time and date

■ Time and date (1–3)

The regulator has a year clock with setting possibilities for time, day/month and year. Time and date must be correctly set, so that the heating programs can operate to previously carried out programming.

■ Summer time (5/6)

The start of summer time can be set under prog. no. 5; the end of summer time is set under prog. no. 6. The time changing is carried out on the Sunday following the set date.

9.2.2 Operator section

■ Language (20)

This is where you can change the language of the users prompts.

■ Info (22)

- Temporarily: The information display returns to the basic display after 8 minutes.
- Permanently: The information display remains permanently displayed after call-up with the information button.

■ Display of errors (23)

Program no. 23 can be used to select whether errors are displayed showing just the error code ("Code" option) or the error code with text ("Code and text" option).

■ Contrast of display (25)

You can select the contrast of the display here.

■ Operation lock (26)

If this function is activated the following operating elements are locked:

- Operating mode buttons for heating and drinking water mode

- Rotary selector (room temperature comfort setpoint)
- Presence button (only room unit)

■ Programming lock (27)

If this lock is activated, parameters can be displayed but not changed.

- Temporary unlocking:
Press OK and ESC simultaneously for at least 3 s. The lock will be re-activated after leaving the setting level.
- Permanent unlocking:
First temporary unlocking, then prog.no. 27 to Off.

■ Units (29)

Here you can choose between SI units (°C, bar) and US-American units (°F, PSI).

■ Save basic settings (30)

The parameters of the regulator are written into the room unit/backed up (only available for room unit).



Caution

The parameters of the room unit are overwritten! With this, the individual programming of the regulator in the room unit can be ensured.

■ Activate basic settings (31)

The data of the operating unit or room unit are written into the control.



Caution

The control parameters are overwritten. The factory settings are stored in the operating unit.

- Activation of prog. no. 31 at the *operating unit*.
The regulator is reset to **factory setting**.
- Activation of prog. no. 31 at the *room unit*.
The individual programming of the room unit is written into the control.



Important

This parameter is only visible if a suitable standard setting is available in the programming unit.

■ Used as (40)

- Room unit 1/Room unit 2/Room unit 3: this setting establishes which heating circuit the room unit on which this setting is made is to be used. When Room unit 1 is selected, further heating circuits can be assigned under prog.no. 42, whereas when Room unit 2/Room unit 3 is selected only the relevant heating circuit can be operated.
- Operator unit 1/Operator unit 2/Operator unit 3: this setting is provided for pure operation without room functions and is not required in connection with this controller.
- Service unit: this setting is used, for example, to back up or save controller settings.

■ Assignment device 1 (42)

If setting Room unit 1 (prog. no. 40) was selected at the room controller, determine the heating circuits to which room controller 1 is assigned under prog. no. 42.

■ Operation HC2/Operation HC3/P (44/46)

When Room unit 1 or Operator unit 1 (prog.no. 40) is selected, it must be defined under prog.no. 44 or 46 whether the heating circuits HK2 and HK3/P are to be operated together with heating circuit 1 or independently of heating circuit 1.

■ Room temperature device 1 (47)

The assignment of room unit 1 to the heating circuits can be selected here.

- Heating circuit 1 only: The room temperature is sent exclusively to heating circuit 1.
- For all assigned HCs: The room temperature is sent to the heating circuits assigned under prog. no. 42.

■ Action occupancy button (48)

You can select the assignment of the presence key here.

- None: Pressing the presence key has no effect on the heating circuits.
- Heating circuit 1 only: The presence key only affects heating circuit 1.
- For all assigned HCs: The presence key affects the heating circuits assigned under prog. no. 42.

■ Readjustment room sensor (54)

The temperature display of the value transmitted by the room sensor can be corrected here.

■ Software version (70)

Display of the current software version.

9.2.3 Wireless

■ Device list (130-138)

The state of the respective device will be displayed under programme numbers 130 to 138.

■ Delete all devices (140)

The wireless connections to all units is cancelled here.

9.2.4 Time programs

■ General information about the time programs.



Important

Time programs 1 and 2 are always assigned to the respective heating circuits (1 and 2) and only displayed if these heating circuits are present and also turned on in the menu **Configuration** (prog.-no. 5710 and 5715).

Time program 3 can be used for heating circuit 3, for the DHW and for the circulation pump, depending on the setting, and is always displayed.

Time program 4 can be used for the DHW and for the circulation pump, depending on the setting, and is always displayed.

Time program 5 is not assigned a function and can be freely used for any application using an output QX.

■ Preselection (500 – 600)

Selection of weekday or day blocks. The day blocks (Mon-Sun, Mon-Fri and Sat-Sun) assist the adjustment. The set times are only copied to the individual weekdays and can be changed in the individual day settings as required.

The times of the individual weekdays always determine the heating program.



Important

If a time in a group of days is changed, all 3 start/stop phases will be copied to the day group automatically.

To select groups of days (Mon-Sun, Mon-Fri or Sat-Sun), turn the control knob anti-clockwise; to select individual days (Mon, Tue, Wed, Thu, Fri, Sat, Sun), turn the control knob clockwise.

■ Heating phases (501 — 606)

Up to 3 heating phases can be set per heating circuit. These are active on the days selected under Preselection (prog.no. 500, 520, 540, 560, 600). During the heating phases the system heats to the set comfort setpoint. Outside the heating phases, the system heats to the reduced setpoint.



Important

The time programs are only activated in Automatically operating mode.

■ Copy? (515–615)

The time program for one day can be copied and assigned to another or several other days.



Important

Day blocks cannot be copied.

■ Default values (516–616)

Setting of the default values given in the setting table

9.2.5 Holiday programs

■ Preselection (641 - 661)



Important

The heating circuits may be set to a selectable operation level with the holiday programme during a certain holiday period.

8 holiday periods can be selected with this preselection.

■ Start of holiday (642 - 662)

Entering the holiday start.

■ End of holiday (643 - 663)

Entering the holiday end.

■ Operating level (648-668)

Selection of the operating level (Reduced or Protection) for the holiday programme



Important

A holiday period always ends on the last day at 12:00 AM (23:59). The holiday programmes are only activated in the operation mode Automatically.



See

See also the User manual EC five.

9.2.6 Heating circuits

■ Operating mode (700, 1000, 1300)

The operating mode can be set via the operation mode button at the boiler or at the room device. For other service tools, the operating mode is set via this control line.

- Protection: The heating is switched off in protection mode. The room remains protected against frost however (Frost protection setpoint, e.g. prog. no. 714).
- Automatic: In automatic mode, the room temperature is controlled in accordance with the time program that is selected.
- Reduced: In reduced operation mode the room temperature is kept constantly to the set Reduced setpoint(e.g. prog. no. 712).
- Comfort: In comfort mode the room temperature is kept constantly to the set Comfort setpoint(e.g. prog. no. 710). Eco functions are not activated.

■ **Comfort setpoint (710, 1010, 1310)**

Setting of the comfort setpoint in the heating phases. Without room sensor or with the room influence switched off (prog.no. 750, 1050, 1350), this value is used for calculation of the flow temperature, to theoretically reach the set room temperature.

■ **Reduced setpoint (712, 1012, 1312)**

Setting of the desired room temperature during the reduced heating phase. Without room sensor or with the room influence switched off (prog.no. 750, 1050, 1350), this value is used for calculation of the flow temperature, to theoretically reach the set room temperature.

■ **Frost protection setpoint (714, 1014, 1314)**

Setting of the required room temperature during frost protection mode. Without room sensor or with the Room influence(prog.no. 750, 1050, 1350), this value is used for calculation of the flow temperature, to theoretically reach the set room temperature. The heating circuit remains turned off until the flow temperature drops so far that the room temperature falls below the frost protection temperature.

■ **Heating curve slope (720, 1020, 1320)**

Using the heating curve, the flow temperature setpoint is formed that is used to regulate the heating circuit, subject to the outside temperature. The gradient indicates how much the flow temperature changes by with changing outside temperature.

Fig.42 Heating curve diagram

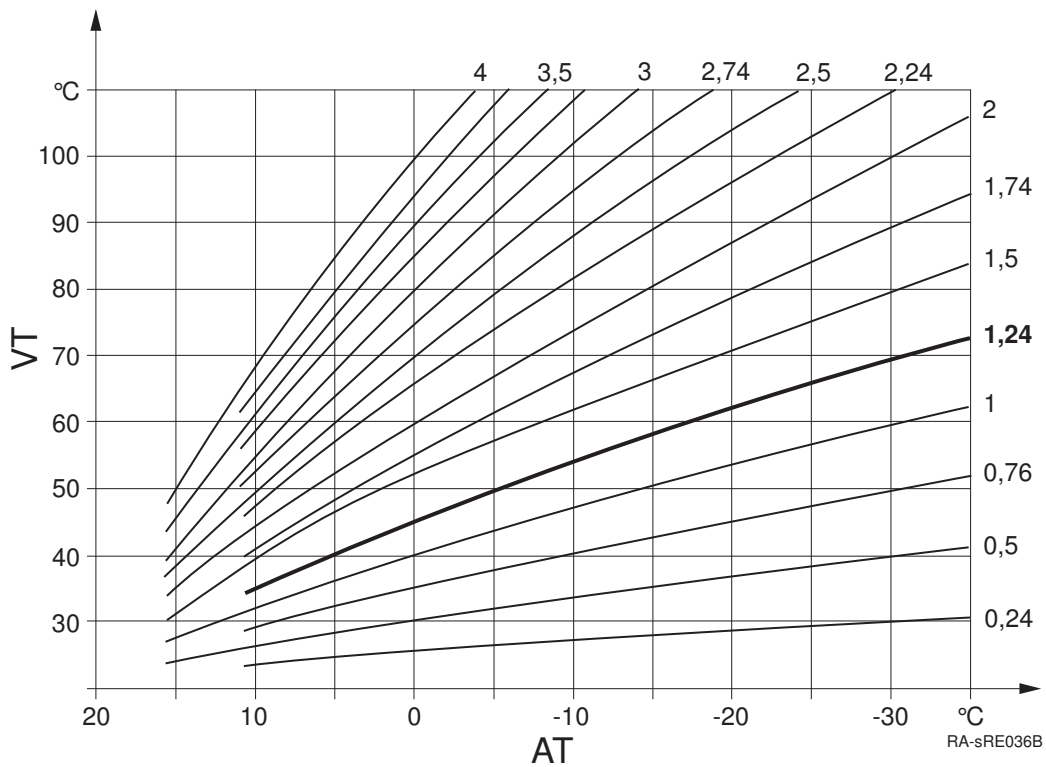

AT Outdoor temperature

VT Flow temperature

Determination of the heating curve gradient

Enter the lowest calculated outside temperature in accordance with the climate zone (e.g. -12 °C in Frankfurt) into the diagram (see fig.) (e.g. vertical line at -12°C). Enter the maximum flow temperature of the heating circuit, which is reached by calculating with -12 °C outside temperature at 20 °C room temperature (e.g. horizontal line at approx. 55 °C).

The intersection of both lines provides the value for the heating curve gradient.

■ Heating curve displacement (721, 1021, 1321)

Heating curve correction by parallel offset if the room temperature is generally too high or too low.

■ Heating curve adaption (726, 1026, 1326)

Automatic adaptation of the heating curve to the actual conditions, as a result of which no correction of the heating curve slope is required.



Important

Automatic adaptation of the heating curve requires the connection of a room sensor. The value for Room influence (see prog. no. 750, 1050, 1350) must be set between 1% and 99%. Should there be radiator valves in the lead room (where the room sensor is installed), these must be fully opened.

■ Summer/winter heating limit (730, 1030, 1330)

Fig.43 Summer/winter heating limit

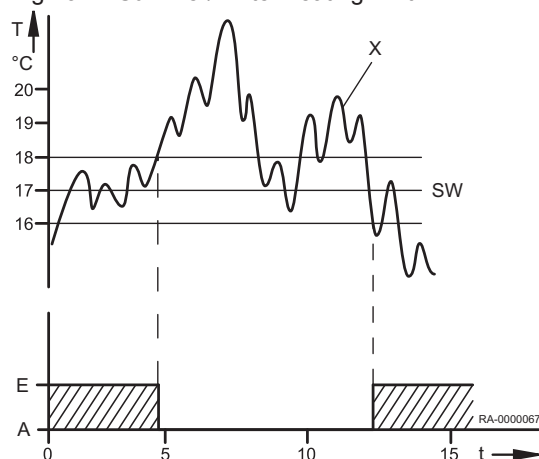

A Off

E On

SW Summer/winter heating limit

T Temperature

t Time

x Outside temp attenuated (prog.no. 8703)

The heating circuit switches to summer operation as soon as the average outside temperature over the past 24 hours rises 1°C above the value set here. As soon as the average of the outside temperatures of the last 24 hours drops 1°C below the value set here, the heating circuit switches back into winter mode.

■ 24-hour heating limit (732, 1032, 1332)

The 24-hour heating limit shuts off the heating circuit if the current outside temperature increases up to the differential set here to the current operating level (reduced or comfort setpoint). The heating switches on again if the current outside temperature falls again below the set differential minus 1 °C.



Important

In the operating mode **continuous mode** ☀ or ☾ this function is not activated.

■ Flow temp setpoint min (740, 1040, 1340) and Flow temp setpoint max (741, 1041, 1341)

With this function, a range can be defined for the flow setpoint. When the flow temperature setpoint reaches the respective limit, this remains constant, even if heat demand rises or falls.

If a pump heating circuit is operated parallel with other requirements, it can cause higher resulting temperatures in the pump heating circuit.

■ Flow temp setpoint room stat (742, 1042, 1342)

For room thermostat mode the flow setpoint set here applies.

With the setting --°C, the value calculated via the heating curve is used as the flow setpoint.

■ Swi-on ratio room stat (744, 1044, 1344)

The boiler tries to adapt the flow temperature so that the switch-on ratio set under this parameter is achieved by the ambient thermostats

■ **Delay heat request (746, 1046, 1346)**

The boiler heat request is forwarded to the burner delayed by the time set here. In this way a slowly opening mixer can already start up before the burner goes into operation.



Important

If the option Absolute is selected under prog.no. 1630, the value 0 must be set under this prog.no. For special functions (e.g. chimney-sweep function) the delay does not have an effect (see prog.no. 2470).

■ **Room influence (750, 1050, 1350)**

The flow temperature is calculated by means of the heating curve subject to outside temperature. This type of control assumes that the heating curve is set correctly, since room temperature is not taken into consideration with this setting.



Important

However, if there is a room unit (e.g. RGP) is connected and the setting "room influence" is set between 1 and 99%, the deviation of the room temperature compared to the set point is recorded and taken into consideration in the temperature control. In this way any external heat can be taken into account enabling a constant room temperature to be achieved. The influence of the deviation can be set in percentage. The more representative the lead room is (correct room temperature, correct installation location etc.), the higher the value can be set, giving the room temperature even greater relevance.



Caution

Should there be radiator valves in the lead room (where the room sensor is installed), they must be opened fully.

- Setting for weather compensation with room influence: 1% - 99%
- Setting for pure weather compensation: ---%
- Setting for pure room compensation: 100%

■ **Room temp limitation (760, 1060, 1360)**

- TRx** Room temperature actual value
- TRw** Room temperature setpoint
- SDR** Room switching difference
- P** Pump
- t** Time
- 1** On
- 0** Off

The heating circuit pump is switched on or off subject to room temperature in line with the switching differential set here. The switch-off point of the pump is set as the difference to the set room setpoint. The pump switch-on point is 0.25 °C below the room setpoint. This function is only possible with a room device (e.g. RGP) and active room influence.



Important

A room sensor must be connected. This function only applies to pumped heating circuits.

Fig.44 Room temp limitation

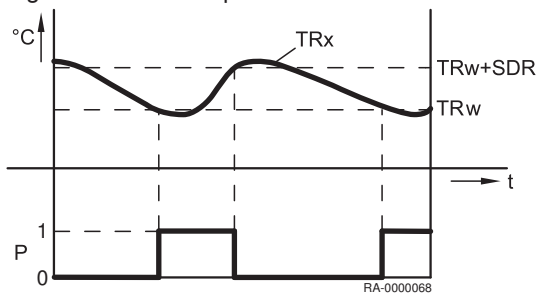

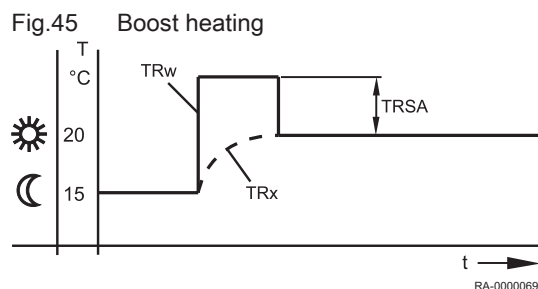

■ Boost heating (770, 1070, 1370)

- TRw** Room temperature setpoint
- TRx** Room temperature actual value
- TRSA** Room temperature setpoint-raised

The boost heating becomes active when the room temperature setpoint is switched over from protection or reduced mode to comfort mode. During the boost heating, the room temperature setpoint is increased by the value set here. This causes the actual room temperature to rise to the new temperature setpoint quickly.

Without room sensor or without room influence, boost heating is implemented in accordance with an internal calculation. Due to the room setpoint acting as a basis, the effect of the duration of the boost heating and that of the flow temperature works differently for each outside temperature.

■ Quick setback (780, 1080, 1380)

Quick reduction becomes active if the room temperature setpoint is switched from comfort level to another operating level (reduced mode or protection mode). During quick reduction the heating circuit pump is switched off and the mixing valve is also closed in the case of mixed circuits. During quick reduction no heat requirement is sent to the heat generator.

Quick reduction is possible with or without room sensor: with room sensor the heating circle function is switched off until the room temperature has dropped to the reduced setpoint or frost protection setpoint. When the room temperature has dropped to the reduced setpoint or the frost protection setpoint, the heating circuit pump starts again and the mixing valve is enabled. Without room sensor the quick reduction switches the heater off depending on the outside temperature and the building time constant (prog.no. 6110) until the temperature has theoretically dropped to the reduced target value or the frost protection value.

Tab.15 Duration of the quick reduction

Duration of the quick reduction for reduction by 2°C in hrs:							
Outside temperature mixed:	Building time constant (configuration, prog.no. 6110)						
	0 hrs	2 hrs	5 hrs	10 hrs	15 hrs	20 hrs	50 hrs
15°C	0	3.1	7.7	15.3	23		
10°C	0	1.3	3.3	6.7	10	13.4	
5°C	0	0.9	2.1	4.3	6.4	8.6	21.5
0°C	0	0.6	1.6	3.2	4.7	6.3	15.8
-5°C	0	0.5	1.3	2.5	3.8	5	12.5
-10°C	0	0.4	1	2.1	3.1	4.1	10.3
-15°C	0	0.4	0.9	1.8	2.6	3.5	8.8
-20°C	0	0.3	0.8	1.5	2.3	3.1	7.7
Duration of the quick reduction for reduction by 4°C in hrs:							
Outside temperature mixed:	Building time constant (configuration, prog.no. 6110)						
	0 hrs	2 hrs	5 hrs	10 hrs	15 hrs	20 hrs	50 hrs
15°C	0	9.7	24.1				
10°C	0	3.1	7.7	15.3	23		
5°C	0	1.9	4.7	9.3	14	18.6	
0°C	0	1.3	3.3	6.7	10	13.4	
-5°C	0	1	2.6	5.2	7.8	10.5	26,2
-10°C	0	0.9	2.1	4.3	6.4	8.6	21.5
-15°C	0	0.7	1.8	3.6	5.5	7.3	18.2
-20°C	0	0.6	1.6	3.2	4.7	6.3	15.8

■ **Optimum start control max (790, 1090, 1390) and Optimum stop control max (791, 1091, 1391)**

Fig.46 Optimum start and stop control

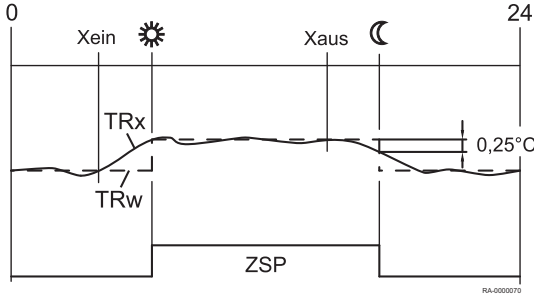

- Xon** Start time set forward
- Xoff** Stop time set forward
- ZSP** Time program
- TRw** Room temperature setpoint
- TRx** Room temperature actual value

The optimisation of the on/off switching times is a function of time and possible with or without room unit. With a room unit the changeover of operating level compared to the programmed time moves forward so that the building dynamics (heat-up and cool-down times) are taken into account. In this way the required temperature level is reached exactly at the programmed time. If this is not the case (too early or too late) a new switching time is calculated that is applied next time.

Without room sensor an advance time is calculated based on the outside temperature and the building time constant (prog. no. 6110). The optimisation time (advance) is limited here to a maximum value. By setting the optimisation time = 0, the function is switched off.

■ **Reduced setp increase start (800, 1090, 1390) and Reduced setp increase end (801, 1101, 1401)**

Fig.47 Reduced setpoint increase

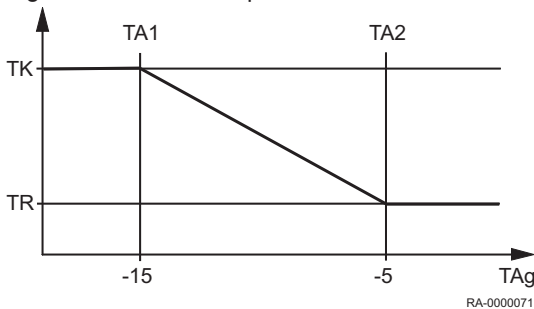

- TA1** Reduced setpoint increase start
- TA2** Reduced setpoint increase end
- TK** Comfort setpoint
- TR** Room temperature reduced setpoint
- TAg** Outside temperature mixed

When only a small heating output is required to cover demand, the reduced room setpoint can be increased in the case of cold outside temperatures. This increase is subject to outside temperature. The lower the outside temperature, the higher the reduced room temperature setpoint will be increased. The start and end of the increase can be selected. Between these two points there is a linear increase of the "reduced setpoint" up to the "comfort setpoint".

■ **Continuous pump operation (809, 1109, 1409)**

This function is used to suppress the pump switching off during the quick reduction and when the room setpoint is reached (room thermostat, room sensor or room model).

- No: the heating circuit pump /boiler pump can be switched off by quick reduction or reaching the room set point.
- Yes: the heating circuit pump/boiler pump remains switched on even during the quick reduction and after the room setpoint has been reached.

■ **Overtemp prot pump circuit (820, 1120, 1420)**

This function prevents overheating of the pump heating circuit by switching the pump on and off, if the flow temperature is higher than the flow temperature required according to the heating curve (e.g. in case of higher requests from other consumers).

■ **Mixing valve boost (830, 1130, 1430)**

The heat request of the mixed heating circuit to the heat source is raised above the value set here. This boost is intended to correct temperature fluctuations to be able to be compensated with the mixer controller.

■ **Actuator running time (834, 941, 1134)**

Setting the actuator running time of the mixing valve used.

For mixing circuits, a kick-start of the mixer drive is carried out after a pump kick-start (pump is OFF). In this case, the mixer is controlled in direction OPEN and CLOSED.

Fig.48 Temperature profile of the floor curing function

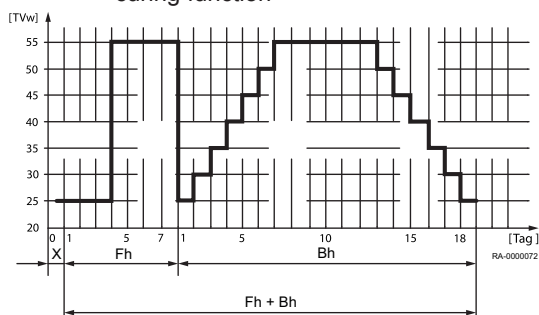

The time of activation in direction OPEN corresponds to the drive running time.

■ Floor curing function (850, 1150, 1450)

- X Start day
- Fh Functional heating
- Ch Curing heating

The floor curing function serves controlled drying out of screed floors

- Off: The function is switched off.
- Functional heating: Part 1 of the temperature profile is run automatically.
- Curing heating: Part 2 of the temperature profile is run automatically.
- Functional/curing heating: The whole temperature profile is run automatically.
- Manually: Manual control to the screed setpoint.



Caution

Observe the requirements and standards issued by the screed manufacturer.

A correct function is only possible with a correctly installed heating system (hydraulic, electrical systems and settings).

Deviations can result in damage to the screed.

The screed function can be stopped prematurely by setting **0=OFF**.

■ Floor curing setp manually (851, 1151, 1451)

Setting of the temperature to which manual control is carried out with floor curing function activated.

■ Floor curing setp current (855, 1155, 1455)

Display of the current floor curing setpoint.

■ Days completed.current (856, 1156, 1456)

Display of the current floor curing function day.

■ Excess heat draw (861, 1161, 1461)

If the excess temperature draw is activated via input H1 to H5 or a maximum temperature is exceeded in the system, this excess heat energy can be released by a heat draw of the room heating.

- Off: The function is switched off.
- Heating mode: The function is only limited to one draw-off during the heating times.
- Always: The function is generally released.

■ With buffer (870, 1170, 1470)

This parameter establishes whether the heating circuit can be supplied by a buffer or storage tank or only by a heat generator. The function also determines whether the system pump goes into operation when a heat demand is submitted.

- No: The heating circuit is supplied from the boiler.
- Yes: The heating circuit can be supplied from the buffer storage tank.

■ With prim contr/system pump (872, 1172, 1472, 5092)

This parameter establishes whether a zone system pump goes into operation with a heat demand of the heating circuit. This system pump is based on the segment in which this controller is located (LPB bus system) and which is controlled with a primary control.

- No: The heating circuit is supplied without primary controller/system pump.
- Yes: The heating circuit is supplied from the primary controller by the system pump.

■ Pump speed reduction (880, 1180, 1480)

The speed of the heating circuit pump can be regulated according to the *operating level* or *pump curve*.

- *Operating level*: With this option the speed of the heating circuit pump is actuated according to the operating level. The pump is controlled in operating level *Comfort* (incl. optimization) or during active floor curing function at maximum speed. With reduced operating level the pump is controlled with the parameterized minimum speed.
- *Characteristic*: With the weather-compensated control variant (with or without ambient temperature compensation), the speed of the heating circuit pump will be kept at the minimum speed for as long as it remains possible to meet the heat demand. In order to enable the heat demand to be met at reduced speed, the heating curve is increased. This flow increase is parametrizable. This setting defines the flow increase in percent at minimum heating circuit pump speed. The speed is only increased when the maximum permitted flow setpoint is reached.
- Temp differential nominal: The spread between boiler flow temperature and boiler return temperature is called the temperature rise.



Important

Since regulation is via the boiler sensor, this setting is only suitable if one pump heating circuit is available.

■ Pump speed min (882, 1182, 1482)

The minimum speed for the heating circuit pump can be specified using this function.

■ Pump speed max (883, 1183, 1483)

The maximum speed for the heating circuit pump can be specified using this function.

■ Curve readj at 50% speed (888, 1188, 1488)

Correction of the flow setpoint with reduction of the pump speed by 50%. The correction is calculated using the difference from the flow setpoint according to the heating curve and current room setpoint.

■ Flow setp readj speed ctrl (890, 1190, 1490)

Here it can be specified whether the calculated flow setpoint correction is included in the temperature request or not.

- No: The temperature request remains unchanged. The calculated correction value is not added.
- Yes: The temperature request includes the flow setpoint correction.

■ Operating level changeover (898, 1198, 1498)

When an external timer is used above the inputs *Hx* selection of the operating level to which the heating circuits are to be switched is possible.

- Protection
- Reduced
- Comfort

■ Optg mode changeover (900, 1200, 1500)

With external change of operating mode via *Hx* it can be selected whether during automatic operation it is changed from comfort set point to the frost prevention setpoint or reduced setpoint.

9.2.7 Domestic water

■ Operating mode (1600)

The domestic hot water charging can be switched to On, Off or Eco mode using "operating mode".

- Off: The DHW is kept permanently at frost protection temperature (5°C).

- On: The DHW charging is done automatically to the DHW nominal setpoint or the DHW reduced setpoint based on the set DHW release.

■ Nominal setpoint (1610)

Setting the drinking water nominal value

■ Reduced setpoint (1612)

Setting the DHW reduced setpoint.

■ Nominal setpoint max (1614)

Set the maximum permissible DHW nominal value.

■ Release (1620)

- 24h/day: The DHW temperature will be continuously controlled to the nominal drinking water temperature value independent from the time programmes.
- Time programs HCs: The DHW temperature will be switched over between the nominal DHW temperature value and the reduced nominal DHW temperature value depending on the time programs. Every time, the switching-on time is moved forward.
 - It is moved forward by 1 hour.

Fig.49 Release depending on the time programmes of the heating circuits (example)

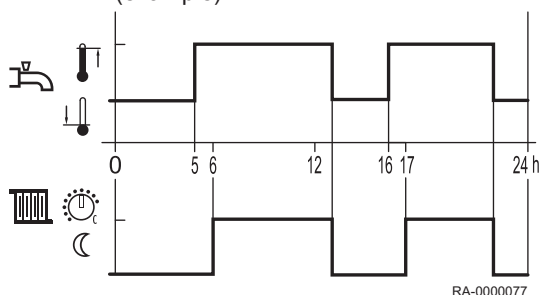
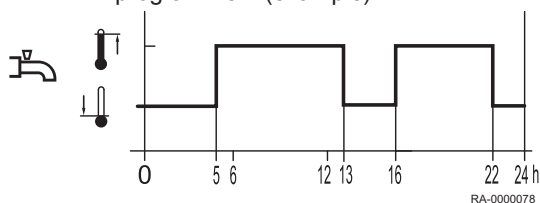

Fig.50 Release according to time programme 4 (example)



Time program 4/DHW: The DHW temperature is changed over between the DHW temperature setpoint and the reduced DHW temperature setpoint independently of time programs of the heating circuit. For this, time program 4 is used.

■ Charging priority (1630)

This function ensures that the boiler capacity is primarily made available for DHW in case of simultaneous capacity demand by room heating and DHW.

- Absolute: Mixer and pumped heating circuits are blocked until the DHW has been heated up.
- Shifting: Should the boiler capacity not be sufficient to heat up DHW, mixer and pumped heating circuits will be restricted.
- None: Charging DHW is carried out in parallel with heating operation.
- MC shifting, PC absolute: Pumped heating circuits are blocked until the DHW has been heated up. Should the boiler capacity not be sufficient, the mixer circuit will also be restricted.

■ Legionella function (1640)

Function to kill legionella germs by heating up to the set legionella function setpoint (see programme number 1645).

- Off: Legionella function is switched off.
- Periodically: Legionella function is repeated periodically, depending on the set value (prog. no. 1641).
- Fixed weekday: Legionella function will be activated on a certain weekday (prog. no. 1642).

■ Legionella funct periodically (1641)

Setting the interval for the legionella function periodically (recommended setting in case of additional drinking water heating by solar plant in connection with a storage tank mixing pump).

■ Legionella funct weekday (1642)

Selection of the weekday for the legionella function.

■ Legionella funct time (1644)

Setting the start time for the legionella function. With setting --- the legionella function will be carried out the first time DHW heating is enabled.

■ Legionella funct setpoint (1645)

Selecting the set temperature required for killing the bacteria.

■ Legionella funct duration (1646)

With this function, the time is set during which the legionella function setpoint is activated to kill germs.



Important

If the colder storage tank temperature rises to above the **legionella function setpoint** -1 K, the **legionella function setpoint** is considered as met and the timer starts running. If the storage tank temperature drops by more than the switching difference +2K below the required **legionella function setpoint**, the duration has to be met again. If no duration has been set, the legionella function is met immediately when the **legionella function setpoint** is reached.

■ Legionella funct circ pump (1647)

- On: The circulation pump will be switched on in case of active legionella function.



Warning

When legionella function is active, there is a risk of scalding at the draw-off points.

■ Circulating pump release (1660)

- Time program 3/HC3: The circulating pump is released subject to time program 3 (see prog. no. 540 to 556).
- DHW release: The circulating pump is released when DHW heating is released.
- Time program 4/DHW: The circulating pump is released subject to time program 4.
- Time program 5: The circulating pump is released subject to time program 5.

■ Circulating pump cycling (1661)

To save energy, the circulation pump is switched on for 10 minutes and off for 20 minutes within the release time.

■ Circulation setpoint (1663)

If sensor B39 is placed in the domestic water distribution line, circulation pump Q4 is switched on as soon as the sensor value falls below the set value. The pump then runs at a fixed rate for 10 minutes or longer until the setpoint has been reached again. There is always a fixed difference of 8 K between the setpoint for the domestic water storage tank and the setpoint for sensor B39 (program no. 1663). This is intended to ensure that the circulation setpoint can also be reached and the circulation pump does not run indefinitely.

Example 1

- DHW setpoint: 55 °C (nominal setpoint)
- Circulation setpoint: 45 °C

→ The circulation pump switches on if the sensor value falls below 45 °C, and runs for at least 10 minutes.

Example 2

- DHW setpoint: 50 °C (nominal setpoint)
- Circulation setpoint: 45 °C

→ The circulation pump switches on if the sensor value falls below 42 °C (50 °C - 8 °C), and runs for at least 10 minutes.

■ Optg mode changeover (1680)

Using external switching above the entrance H1 it can be selected into which operating mode is switched into.

- *None*: The external changeover does not affect the DHW operating mode.
- *Off*: DHW is switched to the operating mode "Off".
- *On*: DHW is switched to the operating mode "On".

9.2.8 Consumer circuits/swimming pool circuit

■ Flow temp setp cons request (1859, 1909, 1959)

Setting of the flow setpoint is done with this function, which is effective during active request of the consumer circuit.

■ DHW charging priority (1874, 1924, 1974)

Setting as to whether domestic hot water charging takes priority over the consumer circuit/swimming pool circuit or not.

■ Excess heat draw (1875, 1925, 1975)

If an excess temperature discharge is activated, the excess energy can be discharged heat being drawn by the consumer circuits. This can be set separately for each consumer circuit.

■ With buffer (1878, 1928, 1978)

This parameter establishes whether the heating circuit can be supplied by a buffer or storage tank or only by a heat generator. The function also determines whether the system pump goes into operation when a heat demand is submitted.

- *No*: The heating circuit is supplied from the boiler.
- *Yes*: The heating circuit can be supplied from the buffer storage tank.

■ With prim contr/system pump (1880, 1930, 1980)

- *No*: The consumer circuit is supplied without primary control unit/system pump
- *Yes*: The consumer circuit is supplied from the primary controller on/by the system pump.

9.2.9 Swimming pool

■ Setpoint solar heating (2055)

When solar energy is used, the swimming pool is heated to the setpoint set here.

■ Setpoint source heating (2056)

When using the generator heating, the swimming pool is heated to the setpoint set here.

■ Charging priority solar (2065)

Setting of which priority the swimming pool will be solar heated. The priority for the DHW and charging buffer is set under Prog. no. 3822.

- *Priority 1*: Charging the swimming pool has top priority.
- *Priority 2*: Charging the swimming pool has middle priority (between the domestic water and the buffer storage tank).

- Priority 3: Charging the swimming pool has lowest priority (after the domestic water and the buffer storage tank).



Important

Release and priority can also be affected by the Hx inputs (see also program no. 3822).

■ Swimming pool temp max (2070)

If the swimming pool temp reaches the heating limit set here, the collector pump is switched off. It is again released if the swimming pool temp has dropped by 1°C below the maximum heating limit temperature.

■ With solar integration (2080)

Setting, of whether the swimming pool heating can be done by solar energy or not.

9.2.10 Primary contr/system pump

The primary controller enables the flow temperature to be mixed up or down for heatinggroups with flow temperature setpoints that are lower or higher than the temperature present on the rail. The feed pump can overcome the pressure drop to heatinggroups that are further away.

■ Flow temp setpoint min (2110) and Flow temp setpoint max (2111)

With these boundaries a range for the flow setpoint can be defined.

■ Syst pump on heat gen lock (2121)

This parameter can set whether the system pump is also locked or not when the generator lock is active.

- Off: The system pump is not locked.
- On: When the generator lock is active the system pump is also locked.

■ Mixing valve boost (2130)

For the admixture the boiler flow temperature actual value must be higher than the requested setpoint of the mixer flow temperature, since this cannot be corrected otherwise. The controller forms the boiler temperature setpoint from the boost set here and the current flow temperature setpoint.

■ Actuator running time (2134)

Setting the actuator running time of the mixing valve used.

■ Primary contr/system pump (2150)

- Before buffer: The primary controller/feed pump is arranged with existing buffer storage tank hydraulically upstream of the buffer storage tank.
- After buffer: The primary controller/feed pump is arranged with existing buffer storage tank hydraulically downstream of the buffer storage tank.

9.2.11 Boiler

■ Release below outside temp (2203)

The boiler is only put into operation if the mixed outside temperature is below the threshold set here. The switching difference is 0.5°C.

■ Full charging buffer (2208)

Under prog. no. 4810 (full charging buffer storage tank) is selected, whether and when the buffer storage tank is fully charged despite automatic generator lock. Program no. 2208 is used to set whether the boiler takes part in the full charging or not.

- Off: The boiler does {1}not{2} take part in the full charging of the buffer storage tank.
- On: The boiler takes part in the full charging of the buffer storage tank.

■ **Setpoint min (2210) and Setpoint max (2212)**

As a protection function the boiler temperature setpoint can be limited below by the minimum setpoint (prog.no. 2210) and above by the maximum setpoint (prog.no. 2212).

■ **Setpoint manual control (2214)**

Temperature to which the boiler is controlled in manual control mode.

■ **Burner running time min (2241)**

Here, the period following the commissioning of the burner is selected during which the shutdown differential is increased by 50%. However, this setting cannot guarantee that the burner remains operational for the selected period.

■ **Burner off time min (2243)**

The boiler minimum pause time only takes effect between heating requirements coming following in sequence. The boiler minimum pause time blocks the boiler for a set time.

■ **SD burner off time (2245)**

When a switching difference is exceeded, Burner off time min (prog. no. 2243) is aborted. The boiler starts despite pausing time.

■ **Pump overrun time (2250) and Pump overr time after DHW (2253)**

The delay times of the pumps are controlled according to heating mode or drinking water mode.

■ **Frost prot plant boiler pump (2300)**

This parameter can be used to set whether the frost protection system should affect the boiler pump.

- Off: The frost protection system does not affect the boiler pump.
- On: The frost protection system affects the boiler pump.

■ **Boiler pump on heat gen lock (2301)**

Stop of boiler pump in case of activated manual heat generation lock (e.g. via H1).

- Off: Switching off not activated
- On: Switching off activated

■ **Impact heat generation lock (2305)**

This parameter is used to set whether the heat generator lock should be effective only for heating requests or also for DHW requests.

- Heating mode only: Only heating requests are locked. DHW requests are still operated.
- Heating and DHW mode: All heating and DHW requests are locked.

■ **Temp differential max (2316)**

When the pump reaches the maximum speed with the setting temperature rise nominal, the temperature difference increases via the boiler. The value set in temperature rise maximum is not exceeded. This is achieved by reducing the boiler setpoint to the current return temperature plus the value shown here.



Caution

Limiting the boiler rise may only be performed if a modulating heat circuit pump is configured, i.e. if program no. 6085 (Function output P1) is assigned to a heating circuit pump.

■ **Temp differential nominal (2317)**

The spread between boiler flow temperature and boiler return temperature is called the temperature rise.

For operation with a modulating pump, the temperature rise is specified with this parameter.

■ Pump modulation (2320)

- None: The function is switched off.
- Demand: Actuation of the boiler pump occurs at the speed calculated for the DHW pump during DHW mode or with the highest calculated speed for the max. 3 heating circuit pumps during pure heating mode.
The calculated pump speed for heating circuit 2 and 3 is only evaluated if these heating circuits are also dependent on the setting of the diverting valve (parameter *boiler pump/DHW diverting valve control*).
- Boiler setpoint: The boiler pump modulates its speed so that the current setpoint (DHW or buffer storage tank) is achieved on boiler flow. The speed of the boiler pump should be increased within the specified limits until the burner has reached its upper output limit.
- Temp differential nominal: The boiler output is controlled to the boiler setpoint.
The control of the pump speed controls the speed of the boiler pump so that the nominal rise between the boiler return and boiler flow is observed.
If the actual rise is larger than the nominal rise, the pump speed is increased, otherwise the pump speed is reduced.
- Burner output: If the burner is operated with low output then the boiler pump should also run at low speed. During high boiler output the boiler pump should run at high speed.

■ Pump speed min (2322)

The working range can be defined in percent of output for the modulating pump. The control translates the percent data internally to speeds.

The value 0% corresponds to the minimum pump speed.

■ Pump speed max (2323)

The pump speed and with it, the power consumption can be limited via the maximum value.

■ Output nominal (2330) and Output basic stage (2331)

The settings under prog.no. 2330 and prog.no. 2331 are necessary when setting up boiler cascades with boilers of different output.

■ Output at pump speed min (2334) and Output at pump speed max (2335)

If the option burner output is selected under prog. no. 2320, the boiler pump is operated up to the set burner output under prog. no line 2334 to minimum pump speed. From the burner output set under prog. no. 2335 the boiler pump is operated on maximum pump speed. If the burner output lies between these two values, the pump speed for the boiler pump is given by linear conversion.

■ Fan parameters

- Prog.no. 2441: With this parameter the maximum boiler capacity can be limited in heating mode.
- Prog.no. 2444: With this parameter the maximum boiler capacity for the DHW mode can be restricted.



Important

These are calculated values. The actual output must be calculated using a gas meter, for example.

■ Controller delay (2450)

The controller delay is used for a stabilisation of the combustion conditions, especially after a cold start. After release of the firing automation by the controller this remains on the set output for a specified time. Modulation is only released after this time has elapsed.

Prog. no. 2450 is used to set the operating mode at which the controller delay is active.

■ Controller delay fan output (2452)

Boiler capacity which is used during the duration of the control delay.

■ Controller delay duration (2453)

Duration of the control delay. The time duration starts as soon as a positive flame is detected after ignition.

■ Switching diff on HCs (2454), Switching diff off min HCs (2455), Switching diff off max HCs (2456), (2460), Switching diff on DHW (2461) and Switching diff off min DHW (2462) Switching diff off max DHW

- Sd** Switching difference off
Sd1 Switching diff off max HCs, Switching diff off max DHW
Sd2 Switching diff off min HCs, Switching diff off min DHW
Sd3 Switching diff on HCs, Switching diff on DHW
t Time
Ti Actual temperature

To avoid unnecessary switch off during transient effects the switch-off difference adapts dynamically depending on the temperature profile (see fig.).

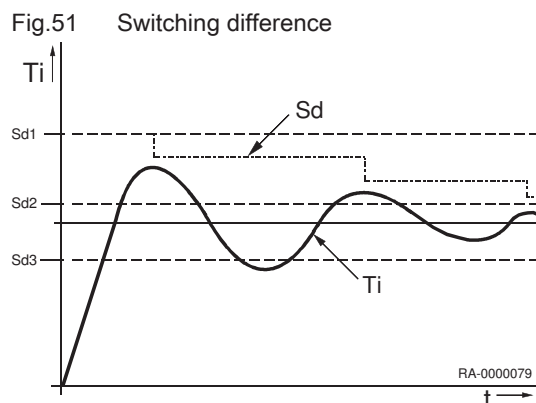

■ Delay heat req special op (2470)

The heat request during special operation (chimney-sweep function, controller stop, manual operation) is sent to the burner delayed by the time set here. In this way slowly opening mixers can already start up before the burner goes into operation. Thus a boiler temperature that is too high can be prevented.

■ Static press superv sh'down (2480)

This parameter controls behaviour when the water pressure is outside the permissible range:

- Lockout position: The boiler is locked.
- Start prevention: The boiler start-up is prevented.

■ Gas energy metering (2550)

This parameter is used to switch gas energy metering on or off. The counter values are not deleted during this process.



Important

Charging priority Absolute If the charging priority is not "Absolute" and there is a requirement for heating operation at the same time as domestic water charging, the gas energy is only taken into consideration in the meter for the heating circuit.

■ Gas energy metering readj (2551)

The gradient of the linear approximation function is adapted here.

- Value < 1: Leads to lower gas energy metering.
- Value > 1: Leads to increased gas energy metering.

A value of 1 means there is no change compared to the approximation function stored.

■ Off delay flue gas damper (2560)

The control of the flue gas damper depends on the control of the fan. If the blower is no longer activated, the flue gas damper is closed. In order to be able to bridge short interruptions in operation and transitions in after-ventilation or drying the chimney, the flue gas damper is switched off with a delay. This parameter sets the duration of the switch-off delay.

9.2.12 Cascade

■ Lead strategy (3510)

The heat generators are switched on and off acc. to the set lead strategy taking the specified output range into account. To switch off the effect of the output range, the limits must be set to 0% and 100% and the lead strategy to late on, late off.

- Late on, early off: Additional boilers are switched on as late as possible (output range max) and switched back off again as soon as possible (output range max). I.e. as few boilers as possible in operation or short running times for additional boilers.
- Late on, late off: Additional boilers are switched on as late as possible (output range max) and switched back off again as late as possible (output range max). I.e. as few switching on and off processes as possible for the boilers.
- Early on, late off: Additional boilers are switched on as early as possible (output range min) and switched back off again as late as possible (output range min). I.e. as many boilers as possible in operation or long running times for additional boilers.

■ Release integral source seq (3530)

A value generated from temperature and time. The lag boiler is switched on when the set limit is exceeded.

■ Reset integral source seq (3531)

The following boiler will be switched off in case of exceeding the setpoint

■ Restart lock (3532)

The restart lock prevents switching a switched off boiler being switched back on again. It is only released again after the set time period has elapsed. This prevents the boiler switching on and off too often and achieves a stable operating condition of the system.

■ Switch on delay (3533)

Too frequent forward and back switching (cycles) of the boiler are avoided by the switch-on delay and therefore a stable operating state is ensured.

■ Switch-on delay DHW (3535)

In addition to parameter 3533, this function can be used to set the delay for the lag boiler to switch on when DHW charging is active. "DHW switch-on delay" applies for simultaneous heat and DHW requests.

■ Auto source seq ch'over (3540)

The sequence of lead boiler and following boiler is defined by the source sequence changeover and in this way, the utilisation of the boilers in a cascade is influenced. After the set time has elapsed, the boiler sequence is changed. The boiler with next higher device address operates as lead boiler.

The operating hours transferred from the generator to the cascade master are decisive for calculating the hours run.

The setting "- -" switches off the source sequence changeover. The lead boiler can be set under program no. 3544. The remaining boilers are connected and disconnected in the order of their LPB device addresses

■ Auto source seq exclusion (3541)

The setting for the generator exclusion is only used in connection with the activated generator sequence (program no. 3540). The generator exclusion can be used to exclude the first and/or last boiler from the automatic changeover.

- None: The boiler sequence changes after expiry of the time set in prog. no. 3540.
- First: The first boiler in the addressing works as the lead boiler; for all the other boilers the boiler sequence is changed after expiry of the time set in prog. no. 3540.

- Last: The last boiler in the addressing always remains the last boiler; for all other boilers the boiler sequence is changed after expiry of the time set in prog. no. 3540.

■ Leading source (3544)

The setting of the leading generator is only used in combination with the fixed sequence of the generator sequence (prog. no. 3540). The generator defined as the leading generator is always put into operation first, and switched off last. The other generators are switched on and off in the sequence of the device address.

■ Return setpoint min (3560)

If the return temperature drops below the return setpoint set here, the return maintenance becomes active. The return maintenance enables influences on the consumers or use of a return controller.

■ Temp differential min (3590)

This function prevents too high cascade return temperatures and improves the switch off behaviour of the cascade. If the temperature difference between the cascade flow and return sensor is smaller than the minimum temperature spread set here, a generator is switched off as early as possible independently of the set lead strategy. Once the temperature difference is sufficient again, the system is switched over to the set lead strategy again.

9.2.13 Solar

If there is sufficient solar energy, the solar system can heat the swimming pool, the domestic water storage tank and the buffer storage tank. The priority for heating the individual storage tanks can be set here. The system is protected by a frost protection function and an overheating protection function.

■ Temp diff on (3810) and Temp diff off (3811)

1 / 0 On / off collector pump

T Temperature

T1 Temp diff on

T0 Temp diff off

TK Collector temperature

TL Charging temperature min buffer storage tank / swimming pool

TS Storage tank temperature

t Time

The switching-on and switching-off point of the collector pump is set with these functions. Basis is the temperature difference between collector temperature and storage temperature.

■ Charg temp min DHW st tank (3812)

In addition to the temperature difference, reaching a certain minimum collector temperature is necessary for the storage charging process.

■ Temp diff on buffer (3813), Temp diff off buffer (3814), Charging temp min buffer (3815), Temp diff on swi pool (3816), Temp diff off swi pool (3817) and Charging temp min swi pool (3818)

The switch-on and switch-off point of the collector pump is set with these functions. The basis for this is the temperature difference between the collector temperature and the temperature of the buffer storage tank/ swimming pool.

In addition to the temperature difference, reaching a certain minimum collector temperature is necessary for the buffer storage tank/swimming pool charging process.

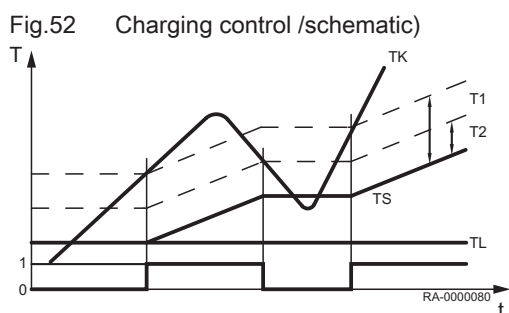



Important

The setting "-" causes program no. 3813, 3814, 3816 and 3817 to apply the values from program no. 3810 (for program no. 3813 and 3816) and program no. 3811 (for program no. 3814 and 3817). The values from program no. 3810 and 3811 are always used for the DHW storage tank.

■ **Charging prio storage tank (3822)**

If several storage tanks are connected to the system, the charging sequence can be determined by setting the charging process.

- None: Every storage tank is charged alternately with a temperature increase of 5 °C, until the setpoint has reached level A, B or C (tab. 1). Once all setpoints have been reached, the setpoints of the next level are applied.
- DHW storage tank: The DHW storage tank is charged as priority during any heating with solar energy at any level (A, B or C). Other consumers with the same level will only be charged afterwards. Once all setpoints have been reached, the setpoints of the next level are applied. For this, heating the DHW cylinder still takes priority.
- Buffer storage tank: During any heating with solar energy, the buffer storage tank is charged first at any level (A, B or C). Other consumers with the same level will only be charged afterwards. Once all setpoints have been reached, the setpoints of the next level are applied. During this process, the charging of the buffer storage tank again takes priority.

Tab.16 Storage tank setpoints

Level	Domestic water storage tank	Buffer storage tank	Swimming pool ⁽¹⁾
A	Nominal value (prog. no. 1610)	Buffer setpoint (drag-pointer)	Setpoint solar heating (prog. no. 2055)
B	Charging temp max (prog. no. 5050)	Charging temp max (prog. no. 4750)	
C	Storage tank temp max (prog. no. 5051)	Storage tank temp max (prog. no. 4751)	Swimming pool temp max (prog. no. 2070)
(1) Program no. 2065 can be used to set whether the swimming pool is charged first, between the domestic water and the buffer storage tank or last.			

■ **Charging time relative prio (3825)**

If the preferred storage tank cannot be charged in accordance with the charging control (e.g. if the temperature difference between the priority storage tank and the collector is too small), priority will be given to the next storage tank or the swimming pool during the time set here.

■ **Waiting time relative prio (3826)**

Transfer of priority is delayed by the time selected here.

■ **Waiting time parallel op (3827)**

Parallel operation is feasible when using solar primary pumps subject to there being sufficient solar energy available. For this, in addition to the storage tank currently being heated, the next storage tank in the priority order can also be heated in parallel. The storage tank switching on for parallel operation can be delayed and stepped by the value set here.

The setting "-" switches off parallel operation.

■ **Delay secondary pump (3828)**

The start-up of the secondary pump can be delayed to ensure that it only switches on if the primary circuit is already at the correct temperature.

■ Collector start function (3830)

If the temperature at the collector with the pump turned off is not measured correctly (e.g. with vacuum tubes), then a periodic switching on of the pump is possible.



Caution

The temperatures at certain collectors cannot be measured correctly if the pump is switched off. For this reason, the pump must be activated from time to time.

■ Min run time collector pump (3831)

The collector pump is periodically switched on for the running time set here.

■ Collector start function on (3832) and Collector start function off (3833)

The time when the collector start function starts or stops is set here.

■ Collector start funct grad (3834)

As soon as there is a temperature increase on the collector sensor, the collector pump switches on. The higher the value selected here, the greater the temperature rise must be.

■ Collector frost protection (3840)

In order to prevent freezing of the collector, the collector pump will be activated at the temperature set here.

■ Collector overtemp prot (3850)

In the event of a risk of overheating, charging of the storage tank will be continued in order to reduce the heat. Charging of the storage tank stops once the storage tank safety temperature has been reached.

■ Evaporation heat carrier (3860)

Pump protecting function, to prevent overheating of the collector pump in case of evaporating danger of the heat carrying medium due to high collector temperature.

■ Pump speed min (3870) and Pump speed max (3871)

The charging setpoint of the storage tank with the highest charging priority and the collector temperature are used for speed regulation. The speed is calculated so that the collector temperature is 2 °C below the start temperature. If the collector temperature increases due to stronger sunlight, the speed is increased. If the collector temperature falls below this setpoint, the speed is reduced. The pump speed can be restricted via the minimum and maximum parameters.

■ Antifreeze (3880)

Information of the antifreeze used.

■ Antifreeze concentration (3881)

Input of antifreeze concentration for usage measurement of solar energy.

■ Pump capacity (3884)

Input of the flow of the installed pump for calculation of the brought in volume for usage measurement.

■ General yield measurement

To enable precise solar yield measurement, the two additional sensors, B63 in the solar flow and B64 in the solar return, should be connected. Without these sensors a solar yield measurement is not possible.

■ Pulse unit yield (3887)

Defines the flow per pulse for the Hx input. The Hx input must be configured to pulse count for this.

9.2.14 Solid fuel boiler

If the solid fuel boiler temperature is high enough, the boiler pump is switched on and the domestic water storage tank and/or the buffer storage tank is heated. The solid fuel boiler requires the Solid fuel boiler sensor B22.

■ Locks other heat sources (4102)

If the solid fuel boiler is warmed up, other heat generators, e.g. oil/gas boilers, are blocked as soon as an increase in the boiler temperature that indicates that the comparative temperature has been exceeded (program no. 4133) has been detected.

■ Setpoint min (4110)

The boiler pump is only put into operation if the boiler temperature has reached the minimum setpoint set here in addition to the necessary temperature difference.

■ Temp diff on (4130), Temp diff off (4131) and Comparative temp (4133)

- 1 / 0 On / off boiler pump
- Bx Comparative actual temperature
- T1 Temp diff on
- T0 Temp diff off
- TKx Boiler temperature
- TS Storage temperature
- t Time

A sufficiently large temperature difference is necessary between the boiler temperature and the comparative temperature for start-up of the pump.

To maintain the comparative temperature, the following settings are available under prog. no. 4133:

- DHW sensor B3 / DHW sensor B31: The comparative temperature is supplied by the DHW sensor B3/B31.
- Buffer sensor B4 / Buffer sensor B41: The comparative temperature is supplied by the buffer storage tank sensor B4/B41.
- Flow temp setpoint: The flow temperature setpoint is used as comparative temperature.
- Setpoint min: The value set in prog.no. 4110 is used as comparative temperature.

■ Pump overrun time (4140)

Pump overrun time setting for the solid fuel boiler pump.

9.2.15 Buffer storage tank

A buffer storage tank can be connected to the system. This can be heated via the heat generator and by solar energy. In cooling mode, it can also be used to store cooling energy. The controller controls the heating/cooling and the forced charging of the buffer storage tank, protects it against overtemperature and maintains the layering in the storage tank as far as possible.

■ Auto generation lock (4720)

The heat generator is only put into operation if the buffer can no longer cover the current heat demand. The following settings are possible:

- None: The automatic heat generator lock is deactivated.
- With B4: The automatic heat generator lock is triggered by the B4 buffer storage tank sensor.
- With B4 and B42/B41: The automatic heat generator lock is triggered by the B4 and B41 (or B42) buffer storage tank sensors.



Important

To activate the heat generator lock, the temperature must be high enough at both sensors.

Fig.53 Storage tank charging

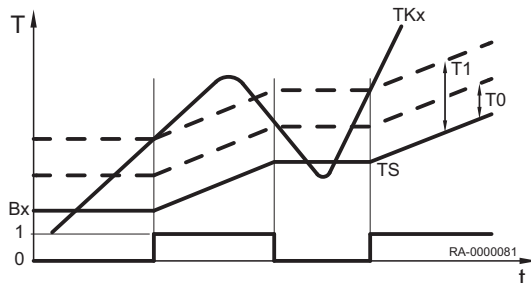

■ Auto heat gen lock SD (4721)

The heat generator is locked if the the temperature in the buffer storage tank is higher than the boiler setpoint+Auto heat gen lock SD.

■ Temp diff buffer/HC (4722)

If the temperature difference between buffer storage tank and heating circuit temperature request is large enough, the heat required by the heating circuit will be taken from the buffer storage tank. The heat generator is locked. This enables a mixer boost, which is not necessary in the event of heating from the buffer, to be compensated for or, if necessary, an undersupply to be approved as well.

■ Min st tank temp heat mode (4724)

If the storage tank temperature of the buffer storage tank drops below this value, the heating circuit is switched of if no generator is available.

■ Charging temp max (4750)

The buffer storage tank is charged from solar energy up to the set charging temperature maximum.



Important

The collector overheating protection function can reactivate the collector pump until the maximum cylinder temperature (90 °C) has been reached.

■ Recooling temp (4755)

If it was necessary to charge the buffer storage tank to above the maximum charging temperature (program no. 4750), recooling down to the recooling temperature set here is carried out as soon as possible. Two functions are available for recooling the buffer storage tank down to the recooling temperature (see program no. 4756 and 4757).

■ Recooling DHW/HCs (4756)

The energy can be discharged via a heat draw by the room heating or the domestic water storage tank. This can be set separately for each heating circuit (see program no. 861, 1161, 1461).

■ Recooling collector (4757)

Recooling when the buffer storage tank temperature is too high by transmitting energy to the environment via the collector area.

- Off: Recooling has been deactivated.
- Summer: Recooling is only active in summer.
- Always: Recooling is always active.

■ With solar integration (4783)

Setting of whether the buffer storage tank can be charged by solar energy.

■ Temp diff on return div (4790), Temp diff off return div (4791) and Compar temp return div (4795)

At the appropriate temperature difference between the return sensor B73 and the selectable comparative temperature the return is re-routed to the lower buffer storage tank section. The function can either be used as return temperature increase or as return temperature decrease. The way this works is defined in prog. no.4796.

Using the definition of the temperature differences in prog. no. 4790 and 4791 the switch on and switch off point of the return redirection is established.

In prog.no. 4795 the buffer storage tank sensor is selected that delivers the value for the comparison with the return temperature, to switch on the return redirection with the aid of the set temperature differences.

**Important**

To activate the return redirection, a Qx relay output (program no. 5890-5892) for the Y15 buffer deflector valve and a Bx sensor input (program no. 5930-5932) for the B73 common return sensor must also be configured.

■ Optg action return diversion (4796)

The function can either be used as return temperature increase or as return temperature decrease.

- Temp decrease: If the return temperature of the consumers is higher than the temperature on the selected sensor (prog. no. 4795), the lower part of the storage tank can be preheated with the return flow. The return temperature drops even lower with this, which leads to a higher efficiency with a condensing boiler, for example.
- Temp increase: If the return temperature of the consumers is lower than the temperature on the selected sensor (prog. no. 4795), the return flow can be preheated by redirecting over the lower part of the storage tank. In this way, for example, return flow preheating can be implemented.

■ Partial charging setpoint (4800)

As a result of the hydraulic uncoupling of the lower part of the buffer storage tank, the volume of the storage tank to be heated is reduced. The remaining, upper part of the storage tank is therefore charged faster. The lower part of the storage tank is heated up first if the upper part of the storage tank is charged.

As soon as the temperature measured on the Buffer sensor B4/B42 has reached the target partial charging value, the changeover valve switches to "Pass through" and the rest of the storage tank is also charged. To do this, a Buffer return valve Y15 and a Buffer sensor B4 or Buffer sensor B42 must be configured.

■ Full charging (4810)

The {1}full charging{2} function enables the released generator to be switched off first despite the automatic generator lock if the buffer storage tank is fully charged. During active function the generator parameterized for the full charging function is only switched off when the full charging setpoint is reached or the boiler must be switched off because of burner control.

- Off: The full charging function is switched off.
- Heating mode: Full charging becomes active if the automatic generator lock blocks the heat source during valid heat request based on the buffer temperature. If the buffer storage tank reaches the requested temperature at the sensor parameterized for the full charging function, the function is ended.
- Always: Full charging becomes active if the automatic generator lock blocks the generator during valid heat request based on the buffer temperature or the heat request is invalid. If the buffer storage tank reaches the requested temperature at the sensor parameterized for the full charging function, the function is ended.

■ Full charging temp min (4811)

The buffer storage tank is charged minimally o the set value.

■ Full charging sensor (4813)

- With B4: For the full charging function the buffer storage tank sensor B4 is considered.
- With B42/B41: For the full charging function the buffer storage tank sensor B42, if not available buffer storage tank sensor B41, is considered.

9.2.16 DHW storage tank

The domestic water storage tank can be charged in a variety of ways:

- Via solar collectors
- Via the buffer storage tank
- Via the oil/gas boiler, the solid fuel boiler or the cascade
- Via an additional generator
- Via an immersion heater

The options available depend on the available components and their configuration. If required, the components can complement each other in the order that is most efficient in terms of energy use.

■ Forward shift charging (5011)

This setting only has an effect if the domestic water release is set in accordance with the time switching program of the heating circuit.

■ Flow setpoint boost (5020)

The boiler temperature setpoint for charging the DHW storage tank consists of the DHW temperature setpoint and the flow setpoint boost.

■ Transfer boost (5021)

Through the transfer, energy can be moved from the buffer storage tank into the DHW storage tank. For this the current buffer storage tank temperature must be higher than the current temperature in the DHW storage tank. This temperature difference is set here.

■ Type of charging (5022)

Charging a stratification cylinder (if available):

- Recharging : The cylinder is only recharged at every DHW demand.
- Full charging: The cylinder is fully charged at every DHW demand.
- Full charging legio: The cylinder is fully charged if the legionella function is enabled; otherwise it is only recharged.
- Full charg 1st time day: During the first charging of the day, the cylinder is fully charged, then recharged.
- Full charg 1st time legio: The cylinder is fully charged during the first charging of the day and if the legionella function is enabled; otherwise it is recharged

Explanations:

- Full charging: The stratification cylinder is fully charged. The heat demand is triggered by the top cylinder sensor TWF (B3), and ended by sensors TWF and TLF (B36) or TWF2 (B31). If only one B3 is installed, recharging takes place automatically.
- Recharging: The stratification cylinder is recharged i.e. only the area up to the cylinder sensor TWF (B3) is heated. The heat demand is triggered and ended by the top cylinder sensor TWF (B3).

■ Switching diff (5024)

If the DHW temperature is lower than the current setpoint minus the switching difference set here, the DHW charging is started. The DHW charging is ended if the temperature of the current setpoint is reached.



Important

At the first DHW release of the day, forced charging is performed. The DHW charging is also started if the DHW temperature is within the switching difference – as long as it is not less than 1 K under the setpoint.

■ Charging time limitation (5030)

During the domestic water charging, the room heating – depending on the selected charging priority (program no. 1630) and the hydraulic circuit – has too little or no power. It is therefore often practical to restrict the time of domestic water charging. After the set time has elapsed, domestic water charging is stopped and locked for the same amount of time before it is resumed.

■ Discharging protection (5040)

This function ensures that the DHW circulation pump (Q3) only switches on when the temperature in the heat source is high enough.

- **Application with sensor**
 - The charging pump is only switched on when the heat source temperature is above the DHW temperature plus half of the heating excess. If the boiler temperature drops below the DHW temperature plus 1/8 of the charging excess during the charging again, the charging pump is switched off again. If two DHW sensors for the DHW charging are parameterized, the lower temperature is considered for the discharge safety function (normally the DHW sensor B31).
- **Application with thermostat**
 - The primary pump is only switched on if the boiler temperature is above the set DHW temperature. If the boiler temperature drops below the DHW nominal setpoint minus the DHW switching difference, charging pump is switched off again.
- Off: The function is switched off.
- Always: The function is always active.
- Automatically: The function is only active if the heat generator cannot deliver heat or is not available (malfunction, generator lock).

■ Discharg protec after charg (5042)

If the parameter is at "On", the discharge protection stops the domestic water pumps Q3 and Q33 from running on as soon as the DHW charging temperature drops below the storage tank temperature B3.

■ Charging temp max (5050)

With this setting, the maximum charging temperature for the connected storage of the solar system is limited. If the DHW-charging value is exceeded, the collector pump switches off.



Important

The collector pump can be re-activated by the collector overheating protection function (see programme no. 3850) until the storage tank safety temperature (90 °C) has been reached.

■ Recooling temp (5055)

Once a recooling function has been activated, it remains in operation until the set Recooling temp in the domestic water storage tank has been reached.

■ Recooling collector (5057)

Recooling of the overhaeted collector through giving off of the energie to the surrounding of the collector.

■ El imm heater optg mode (5060)

- Substitute: The DHW is only heated by an immersion heater if the boiler signals a malfunction or a boiler lock exists.
- Summer: The DHW is heated by an immersion heater if all connecting heating circuits have switched to summer mode. As soon at least one heating circuit is switched to heating mode, the DHW preparation is taken over by the boiler again.



Important

The immersion heater is also used if a boiler malfunction occurs or the boiler is switched off due to a boiler lock.

- Always: DHW is heated exclusively by the immersion heater.

■ El immersion heater release (5061)

- 24h/day: Immersion heater permanently released
- DHW release: Immersion heater released subject to DHW-release (see prog. no. 1620).

- Time program 4/DHW: Release of the immersion heater via the time programme 4 of the local controller.

■ **EI immersion heater control (5062)**

- External thermostat: The controller continuously releases the domestic water preparation with immersion heater within the release time, regardless of the storage tank temperature. The current domestic water setpoint in the controller has no effect. The required storage tank temperature must be set at the external thermostats. The manual push and the Legionella function do not work.
- DHW sensor: The controller releases the domestic water preparation with immersion heater within the release time, depending on the storage tank temperature. The current domestic water setpoint in the controller is complied with. If the sensor input B3 is designed as a thermostat, the temperature will be regulated on the basis of the contact. The manual push can be activated. If the Legionella function is active, charging will be carried out until the Legionella setpoint is reached.



Important

To ensure that the setpoint control works correctly, the thermostat outside of the controller must be set to the maximum storage tank temperature.

■ **Automatic push (5070)**

The DHW-push can be activated manually or automatically. It causes a one-time DHW charging to the nominal setpoint.

- Off: The DHW-push can only be activated manually.
- On: If the DHW temperature drops by more than two switching differences (prog. no. 5024) below the reduced setpoint (prog. no. 1612), it will be recharged once to the DHW nominal setpoint (prog.no.1610).



Important

The automatic push only works if the domestic water operating mode is activated (ON).

■ **Excess heat draw (5085)**

Excess temperature discharge can be triggered by the following functions:

- active inputs Hx
- Buffer storage tank recooling
- Solid fuel boiler excess temperature discharge

If an excess temperature discharge is activated, the excess energy can be dissipated through the heat discharge of the domestic water storage tank.

■ **With buffer (5090)**

If a buffer storage tank is present, it is necessary to enter whether the domestic water storage tank can be supplied heat from the heat buffer storage tank.

■ **With prim contr/system pump (5092)**

- No: The DHW storage tank is supplied without primary controller/feed pump.
- Yes: The DHW cylinder is supplied from the primary controller on/by the feed pump.

■ **With solar integration (5093)**

This function sets whether the domestic water storage tank can be charged using solar energy.

■ **Pump speed min (5101) and Pump speed max (5102)**

Setting of the minimum and maximum speed of the storage tank charging pump in percent.

■ Speed Xp (5103)

The P-band Xp defines the amplification of the controller. A smaller Xp value leads to a higher actuation of the charging pump with equal control difference.

■ Speed Tn (5104)

The reset time Tn determines the reaction speed of the controller when compensating for remaining controller differences. A shorter reset time Tn leads to faster compensating.

■ Speed Tv (5105)

The preholding time Tv determines how long a spontaneous change of the control difference continues to have an effect. A short time only influences the control variable only for a short time.

■ Transfer strategy (5130)

The domestic hot water storage tank can be charged from the buffer storage tank if the buffer storage tank is hot enough. Depending on the hydraulic circuit, this transfer can be carried out using the charging pump Q3 or using the St tank transfer pump Q11. If the domestic water preparation is switched off, the transfer is also switched off.

- Off: Transfer does not take place.
- Always: If the domestic water operating mode is switched on, heat is always transferred to the domestic water storage until the nominal setpoint is reached. If the Legionella function is switched on and the Legionella time is active, heat will be transferred until the Legionella setpoint is reached.
- DHW release: If the domestic water operating mode is switched on, heat is always transferred to the domestic water storage tank until the current setpoint in accordance with the domestic water release times (BZ 1620) is reached. If the Legionella function is switched on and the Legionella time is active, heat will be transferred until the Legionella setpoint is reached.

■ Interm circ boost recharging (5139)

Setpoint boost for charging setpoint on charging sensor B36 with recharging.

■ Intermediate circuit boost (5140)

Setpoint boost for the loading setpoint at the DHW charging sensor B36. The set value is added to the request.

■ Excess interm circ temp max (5141)

With this parameter the end criterion of a full charging during control is specified on the charging sensor B36. If the contents of the stratification cylinder is charged to the bottom, the temperature increases on the charging sensor

■ Flow setp compensation delay (5142)

With the setpoint control, the heat demand is adjusted so that the intermediate circuit temperature DHW charging sensor B36 reaches its setpoint (storage tank setpoint plus intermediate circuit boost). The setpoint control can be switched on or off with the flow setpoint delay parameter ("Off" or value between 0 and 60 s). The setpoint control is delayed by the length of time set under program no. 5142; the temperature is controlled to the setpoint + charging boost.

■ Flow setp compensation Xp (5143)

The mixer valve P-band Xp defines the amplification of the controller. A smaller Xp value leads to higher actuation of the charging pump at the same control difference.

■ Flow setp compensation Tn (5144)

The mixer valve reset time Tn determines the reaction speed of the controller when compensating for remaining controller differences. A shorter reset time Tn leads to faster compensating.

■ Flow setp compensation Tv (5145)

The mixer valve preholding time Tv determines how long a spontaneous change of the control difference continues to have an effect. A short time only influences the control variable for a short time.

■ Full charging with B36 (5146)

Here it can be set whether the end of the full charging is detected via the temperature on the charging sensor B36.

- No: The end of the full charging is detected via the temperature on the upper and lower storage sensor B3 and B31.
- Yes: The end of the full charging is detected via the temperature on the upper storage sensor B3 and on the charging sensor B36.

■ Min start temp diff Q33 (5148)

The DHW interm circ pump Q33 is only put into operation if the temperature in the generator circuit is higher than the upper domestic water storage tank temperature (B3) by at least the temperature difference set here. This maintains the temperature stratification in the storage tank. A setting of -3 °C results in the intermediate circuit pump being switched on as soon as the boiler temperature rises to within 3 °C of the storage tank temperature at B3.

■ Excess interm circ temp del (5151)

Control of the burner output on the charging temperature is activated if the time set here has elapsed since switching on the intermediate circuit pump.

9.2.17 Configuration

■ Heating circuit 1 (5710), Heating circuit 2 (5715) and Heating circuit 3 (5721)

The heating circuits can be switched on or off using this setting. Heating circuit parameters are hidden in the deactivated state.



Important

This adjustment only affects the heating circuits directly and has no influence on operation.

■ DHW sensor B3 (5730)

- DHW sensor B3: There is a DHW storage tank sensor available. The controller calculates the switching points with the corresponding switching difference from the DHW setpoint and the measured DHW storage tank temperature.
- Thermostat: The domestic water temperature is regulated on the basis of the switching status of a thermostat connected to the DHW sensor B3.



Important

No reduced mode is possible when a DHW thermostat is used. This means if reduced mode is active, the DHW preparation is blocked with the thermostat.



Caution

No frost protection for DHW! The domestic water frost protection cannot be guaranteed.

■ DHW ctrl elem Q3 (5731)

- No charging request: DHW charging disabled via Q3.

- Charging pump: DHW charging via the connection of a charging pump to Q3/Y3.
- Diverting valve: DHW charging via the connection of a diverting valve to Q3/Y3.

■ Basic position DHW div valve (5734)

The base position of the diverting valve is the position in which the diverting valve (DV) is in if no request is active.

- Last request: The diverting valve (DV) remains after the last request has ended in this last position.
- Heating circuit: The diverting valve (DV) goes into the heating circuit position after the last request has ended.
- DHW: The diverting valve (DV) goes into the DHW position after the last request has ended.

■ DHW separate circuit (5736)

For multi-boiler systems (cascades), a heat generator can only be temporarily used for charging the domestic hot water. When active charging is carried out, this boiler separates itself hydraulically from the system using a domestic water isolating circuit and is no longer available for the rest of the time that heating mode is active.

- Off: The DHW separate circuit function is disabled. Each available boiler can feed the DHW storage tank.
- On: The DHW separate circuit function is enabled. The DHW charging is only done from the boiler defined for this.



Important

For a domestic water isolating circuit, the DHW ctrl elem Q3 must be set to "Diverting valve" under program no. 5731.

■ Optg action DHW div valve (5737)

Using this parameter the diverting valve position is set, which applies during active output.

- Position on DHW: during active output the diverting valve is in the DHW position.
- Position on heating circuit: during active output the diverting valve is in the heating circuit position.

■ Ctrl boiler pump/DHW valve (5774)

With this parameter it can be defined for special hydraulic systems that the boiler pump Q1 and the diverting valve Q3 only are responsible for DHW and heating circuit 1, however not for heating circuits 2 and 3 or for the external consumer circuits.

- All requests: The diverting valve is connected hydraulically for all requests and switches between DHW mode and the remaining requests. The boiler pump runs for all requests.
- Request HC1/DHW only: The diverting valve is connected hydraulically only for heating circuit 1 and DHW and switches between DHW mode and heat circuit 1 mode. All other requests are not connected hydraulically via the diverting valve (DV) and the boiler pump, but rather directly connected to the boiler.

■ Boiler pump at DHW (5775)

This parameter determines, whether the boiler pump for DHW charging is switched on or off.

■ Solar controlling element (5840)

The solar heating system can also be operated with charging pumps instead of with a collector pump and diverting valves for the storage tank connection.

- Charging pump: When used with charging pump all exchangers can be flowed through simultaneously. Parallel or alternative mode is possible.

- Diverting valve: When used with a diverting valve only one exchanger can be flowed through. Only alternative mode is possible.

■ External solar exchanger (5841)

For solar schemes with two storage connections it must be set whether the external heat exchanger is present and is used *together* for DHW and buffer storage or only *for one of the two*.

■ Combi storage tank (5870)

Combined storage-specific functions are activated with this setting. For instance, the buffer storage immersion heater can be used for heating as well as for DHW.

- No: No combined storage exists.
- Yes: A combined storage exists.

■ Relay output QX1 (5890), Relay output QX2 (5891) und Relay output QX3 (5892)

- None: Relay outputs deactivated.
- Circulating pump Q4: The connected pump serves as a DHW circulation pump (see prog. no. 1660).
- El imm heater DHW K6: With the connected immersion heater, the DHW can be charged according to the operating side DHW storage operating line immersion heater.



Important

The operating mode is set under prog.no. 5060.

- Collector pump Q5: Connection of a circulating pump in case of solar collector use.
- Cons circuit pump VK1 Q15: Connection of a pump at the input Q15/18 for an additional consumer, which is requested via an Hx-input.
- Boiler pump Q1: The connected pump is used for recirculation of the boiler water.
- Alarm output K10: Any new fault will be signalled by means of this alarm relay. The contact is closed with the delay time selected under prog. no. 6612. If no fault message exists, the contact opens without delay.



Important

The alarm relay can be reset without having the fault remedied (see prog. no. 6710). The alarm relay can also be closed temporarily by a message which, for example, leads to restart.

- Heat circuit pump HC3 Q20: Activating the pump heating circuit HC3.
- Cons circuit pump VK2 Q18: Activating the consumer circuit VK2.
- System pump Q14: Connection of a feed pump.
- Heat gen shutoff valve Y4: Connection of a changeover valve for hydraulic de-coupling of the heat generator from the rest of the heating system.
- Solid fuel boiler pump Q10: Connection of a circulation pump for the boiler circuit for the connection of a solid fuel boiler.
- Time program 5 K13: The relay is controlled by the time program 5 according to the settings.
- Buffer return valve Y15: This valve must be configured for the return temperature increase/reduction or partial charging of the buffer storage tank.
- Solar pump ext exch K9: The solar circuit pump for the external heat exchanger K9 must be set here.
- Solar ctrl elem buffer K8: If several exchangers are connected, the buffer storage tank must be set at the respective relay output and the type of solar regulating unit must be defined under prog.no.5840.
- Solar ctrl elem swi pool K18: If several exchangers are connected, the swimming pool must be set at the respective relay output and the type of the solar regulating unit must be defined in prog.no. 5840.
- Swimming pool pump Q19: Connection of a swimming pool pump at the input Q19 .
- Cascade pump Q25: Common boiler pump for all boilers in a cascade.

- St tank transfer pump Q11: The DHW storage tank can be heated by the buffer storage tank subject to it being hot enough. This transfer is brought about by transfer pump Q11.
- DHW mixing pump Q35: Separate pump for storage circulation during active legionella function.
- DHW interm circ pump Q33: Charging pump for DHW cylinder with external heat exchanger.
- Heat request K27: Output K27 is activated as soon as a heat demand exists in the system.
- Heat circuit pump HC1 Q2/Heat circuit pump HC2 Q6: The relay is used for actuating the heating circuit pump Q2/Q6.
- DHW ctrl elem Q3: Depending on the hydraulics a connected DHW charging pump or diverting valve.
- Status output K35: The status output is operated when a command exists from the controller to the burner control. If there is a disturbance, which prevents the burner control from operating, the status output is switched off.
- Status information K36: The output is set when the burner is in operation.
- Flue gas damper K37: This function activates the flue gas damper control. If the flue gas damper control is activated the burner will only start operating when the flue gas damper is open.
- Fan shutdown K38: This output serves to switch the fan off. The output is activated when the fan is needed; otherwise it is not activated. The fan should be switched off as often as possible in order to minimise the total energy consumption of the system.

■ Sensor input BX1 (5930), Sensor input BX2 (5931)

Functions in addition to the basic functions are made possible by configuring the sensor inputs.

- None: Sensor inputs deactivated.
- DHW sensor B31: Lower domestic water sensor, which is used for full charging of the Legionella function.
- Collector sensor B6: First solar collector sensor in a collector field.
- DHW circulation sensor B39: Sensor for DHW circulation return.
- Buffer sensor B4: Upper buffer storage tank sensor.
- Buffer sensor B41: Lower buffer storage tank sensor.
- Common flow sensor B10: Shared flow sensor for boiler cascades or low-loss header sensors.
- Solid fuel boiler sensor B22: Sensor for the acquisition of the temperature of a solid fuel boiler.
- DHW charging sensor B36: DHW sensor for DHW charging systems.
- Buffer sensor B42: Centre buffer storage tank sensor.
- Common return sensor B73: Return sensor for the return diversion function.
- Cascade return sensor B70: Common return sensor for boiler cascades.
- Swimming pool sensor B13: Sensor for measurement of swimming pool temperature.
- Solar flow sensor B63: This sensor is required for the solar yield measurement.
- Solar return sensor B64: This sensor is required for the solar yield measurement.

■ Function input H1 (5950) Function input H4 (5970) and Function input H5 (5977)



Notice

Not all setting options are available for all H-inputs.

- None: No function.
- Optg mode change HCs+DHW: Operating mode changeover for heating circuits to reduced or protection operation (prog. no. 900, 1200, 1500) and blocking of DHW heating if contact at Hx is closed.
- Optg mode changeover DHW: Changeover of the domestic water charging when contact Hx is closed.

- Optg mode changeover HC1 to Optg mode changeover HC3: Operating mode changeover for heating circuits to protection or reduced operation.

i Important

Locking of domestic hot water charging is only possible under the setting **Optg mode change HCs+DHW**.

- Heat generation lock: The boiler is locked if contact at Hx is closed. Depending on parameter 2305, the domestic hot water and consumer circuits are blocked.
The boiler is not blocked for the following functions:
 - Chimney sweep function
 - Controller stop function
 - Manual mode, 0 to 10 V output request
 - Boiler frost-protection function
- Error/alarm message: Closing the input Hx results in a control unit-internal fault message, which will also be signalled via a relay output programmed as an alarm output or in the remote management system.
- Consumer request VK1/Consumer request VK2: The set flow temperature setpoint is activated via the connecting terminals (e.g. a ventilation heater function for door curtain units).

i Important

The setpoint is set under prog.no. 1859/1909.

- Release swi pool source heat: activation triggers heating of the swimming pool by the heat source.
- Excess heat discharge: Active excess heat discharge enables, for example, an external source to force consumers (heating circuit, DHW storage tank, Hx pump) to draw off excess heat with a signal. For each consumer the parameter excess temperature discharge can be set to determine whether the forced signal is taken into account and should therefore take part in the heat discharge or not.
- Release swi pool solar: This function enables the solar swimming pool heater to be released externally (e.g. via a manual switch) or the solar charging priority to be specified as compared to the storage.
- Operating level DHW/Operating level HC1/Operating level HC2/Operating level HC3: The operating level can be set via the contact instead of via the internal time program (external time program)
- Room thermostat HC1 to Room thermostat HC3: With the input a room thermostat request can be generated for the set heating circuit.

i Important

The quick decrease should be switched off for the corresponding heating circuits.

- DHW thermostat: Connection of the DHW thermostat.
- Pulse count: By querying the input the low frequency pulse, e.g. for flow measurement is recorded.
- Checkb sign flue gas damper: Feedback via input H1 in case of activated flue gas damper control.
- Start prevention: With this input a burner start can be prevented. The boiler also remains blocked for all other protection functions.
- Consumer request VK1 10V/Consumer request VK2 10V: The application node external load x receives a voltage signal (DC 0...10 V) as heat request. The linear curve is defined via two fix points (voltage value 1/function value 1 and voltage value 2/function value 2 (only applies to H1)).
- Output request 10V: The generator receives a voltage signal (DC 0...10 V) as output request. The linear curve is defined via two fix points (voltage value 1/function value 1 and voltage value 2 / function value 2 (only applies to H1)).
- Temp measurement 10V: The controller receives a voltage signal (0 - 10 V DC) as a signal for the measured temperature. The corresponding temperature is calculated via the linear curve, which is defined via two fixed points (voltage value 1/function value 1 and voltage value 2 / function value 2).

- Flow measurement Hz: A flow sensor can be connected here which indicates the flow volume via a frequency. The measured frequency signal is converted into a flow rate signal using a parametrisable curve function. This flow rate signal can be assigned to either the domestic water flow rate or the boiler flow rate. If the flow rate measurement is parametrised for both the boiler flow rate and the domestic water flow rate, a fault code "152 parametrisation fault" with the fault response of preventing start-up is generated.

■ **Contact type H1 (5951) Contact type H4 (5971) and Contact type H5 (5978)**

With this function, the contacts can be set as resting contact (contact closed, must be opened for activating the function) or as working contact (contact opened, must be closed for activating the function).

■ **Voltage value 1 H1 (5953), Voltage value 2 H1 (5955) , Function value 1 H1 (5954) and Function value 2 H1 (5956)**

The linear sensor curve is defined over two fixed points. The setting is made with two parameter pairs for **Funktionswert** and **Spannungswert** (F1 / U1 and F2 / U2).

The function value is specified to a factor of 10, i.e. if you require 100°C, you should select "1000".

Example: Consumer request VK1 10V

- 0 V = 0 °C
- 10 V = 100 °C

Tr	Set point temperature
Hx	Input value to Hx
U1	Input value 1
F1	Function value 1
U2	Input value 2
F2	Function value 2

The controller receives a voltage signal (DC 0...10 V) as a signal for the consumer request. The corresponding target value is calculated via the linear curve, which is defined via two fixed points (input value 1 = 0 v / function value 1 = 0 and input value 2 = 10 V / function value 2 = 1000). If the input signal does not reach the limit value of 0.15 V, the heat request becomes invalid and, therefore, ineffective.

■ **Frequency value 1 H4 (5973), Function value 1 H4 (5974), Frequency value 2 H4 (5975) and Function value 2 H4 (5976)**

l/min	Flow rate in litres/minute
Hx	Input value to Hx
E1	Input value 1 [Hz]
F1	Function value 1
E2	Input value 2[Hz]
F2	Function value 2

The linear sensor curve is defined over two fixed points. The setting is made with two parameter pairs for **function value** and **frequency value**. A frequency value is used in place of the voltage values when setting the Flow measurement Hz. The controller receives a signal for the measured flow rate. The corresponding flow rate is calculated via the linear curve, which is defined via two fixed points (input value 1/function value 1 and input value 2/function value 2).

■ **Function output P1 (6085)**

A speed signal can be output at output P1 for the following pumps:

Fig.54 Voltage_value/Function_value

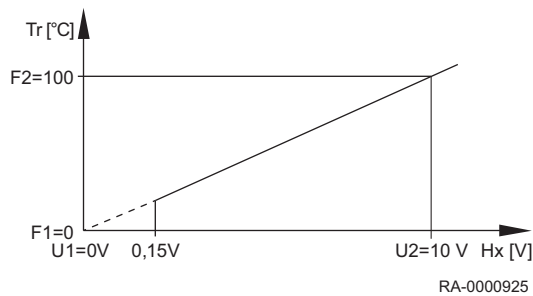

RA-0000925

Fig.55 Example for two different sensor curves

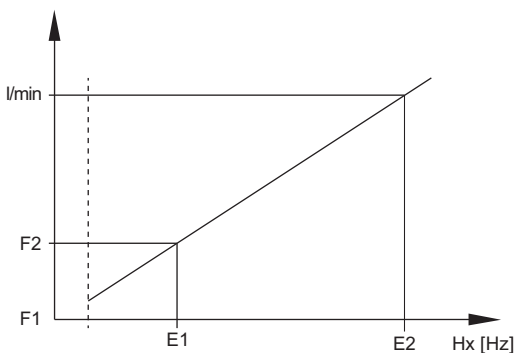

RA-0000926

None | Boiler pump Q1 | DHW pump Q3 | DHW interm circ pump Q33 | Heat circuit pump HC1 Q2 | Heat circuit pump HC2 Q6 | Heat circuit pump HC3 Q20 | Collector pump Q5 | Solar pump ext exch K9 | Solar pump buffer K8 | Solar pump swi pool K18

■ Signal logic output P1 (6086)

The PWM output P1 can be output inverted using signal logic output P1.

■ Sensor type collector (6097)

Selection of used sensor types for measurement of the collector temperature.

■ Readjustm collector sensor (6098)

Setting a correction value for collector sensor 1.

■ Readjustm outside sensor (6100)

Setting a correction value for outside sensor.

■ Time constant building (6110)

The value set here influences the reaction speed of the flow setpoint in case of fluctuating outside temperatures as a function of the building design.

Example values (refer also to Quick setback):

- 40 for buildings with thick walls or outer insulation.
- 20 for buildings of normal building design.
- 10 for buildings of light building design.

■ Central setp compensation (6117)

The central setpoint lead monitors the heat generator setpoint to the required central flow temperature. With the setting the maximum corrector is restricted, even if a larger adaptation should be required.

■ Frost protection plant (6120)

The heating circuit pump is activated without heat request subject to outside temperature. If the outside temperature reaches the lower limit value of -4°C , the heating circuit pump is activated. The pump is activated every 6 hours for 10 minutes when the outside temperature is between -5°C and $+1.5^{\circ}\text{C}$. When the upper limit value of 1.5°C is reached, the pump switches off.

■ Water pressure min (6181)

A maintenance message is indicated from this set water pressure. The boiler output is reduced by 20% to protect the boiler. The message is only reset when the set pressure has been exceeded by 0.2 bar.

■ Save sensors (6200)

Sensor modes can be saved under prog. no. 6200. This is done automatically; however, after change of the heating system (removal of a sensor) the state must be saved again to the sensor terminals.

■ Reset to default parameters (6205)

The factory setting of the regulator is written to the regulator.



Caution

The regulator parameters are overwritten. The factory settings are stored in the regulator.

- Activation of prog. no. 6205:
The regulator is reset to **factory setting**.

■ Check no. heat source 1 (6212), Check no. heat source 2 (6213), Check no. storage tank (6215) and Check no. heating circuits (6217)

The standard device generates a check number to identify the system scheme; this comprises the numbers listed in the table below.

Tab.17 Check no. storage tank (prog.-no. 6215)

Domestic water storage tank		
No buffer storage tank	0	No DHW storage tank
Buffer storage tank	1	Immersion heater
Buffer storage tank, heat generation shutoff valve	4	Primary pump
Buffer storage tank, solar connection, source shut-off valve	5	Charging pump, solar connection
	13	Diverter valve
	16	Primary controller, without heat exchanger
	17	Primary controller, 1 heat exchanger

Tab.18 Check no. heating circuit (prog.-no. 6217)

Heating circuit 3		Heating circuit 2		Heating circuit 1	
0	No heating circuit	00	No heating circuit	00	No heating circuit
1	DHW circulation via boiler circuit pump	01	DHW circulation via boiler circuit pump	01	DHW circulation via boiler circuit pump
2	Heating circuit pump	02	Heating circuit pump	02	Heating circuit pump
3	Heating circuit pump, mixer	03	Heating circuit pump, mixer	03	Heating circuit pump, mixer

■ Software version (6220)

Display of the actual software version.

■ Info 1 OEM(6230), Info 2 OEM (6231), Info 3 OEM (6258), Info 4 OEM (6259) and Parameter set number OEM (6236)

These parameters are EEPROM storage locations that may contain information from the OEM.

9.2.18 LPB system

■ Device address (6600) and Segment address (6601)

The two-part LPB address of the controller consists of the 2-digit segment number and the 2-digit device number.

■ Bus power supply function (6604)

- Off: The controller does not provide the bus power supply.
- Automatically: The bus power supply is switched on and off by the controller in accordance with the power demand of the bus system.

■ Bus power supply state (6605)

- Off: The bus system power supply by the controller is currently inactive.
- On: The bus system power supply by the controller is currently active.

■ Display system messages (6610)

This setting allows system messages which are transmitted via LPB to be suppressed on connected operating elements.

■ System message to alarm relay (6611)

- No: Alarm output K10 is not triggered when a system fault is reported.
- Yes: Alarm output K10 is triggered when a system fault is reported.

■ Alarm delay (6612)

The transmission of the alarm to the BM module can be delayed in the basic device by an adjustable time. This allows the prevention of unnecessary messages to a service location caused by malfunctions which only occur briefly (e.g. temperature monitor queried, communication errors). However, it must be noted that malfunctions which occur briefly and quickly re-occur are also filtered out by this.

■ Action changeover functions (6620)

If the setting Central is activated under prog. no. 6221 and 6223 respectively, the action for this setting can be set. The following settings are possible:

- Segment: The changeover is done for all controllers in the same segment.
- System: The changeover is done for all controllers in the entire system (that is in all segments). The controller must be located in segment 0!

■ Summer changeover (6621)

- Locally: The local heating circuit is switched on and off depending on prog.no. 730, 1030 or 1330.
- Centrally: Depending on the settings made in prog. no. 6620, either the heating circuits in this section or all heating circuits in the entire system are switched on and off.

■ Optg mode changeover (6623)

- Locally: The local heating circuit is switched on and off.
- Centrally: Depending on the settings made in prog. no. 6620, either the heating circuits in this section or all heating circuits in the entire system are switched on and off.

■ Manual source lock (6624)

- Locally: The local generator is locked.
- Segment: All generators in the cascade are locked.

■ DHW assignment (6625)

The domestic hot water assignment stipulates from which heating circuits/cooling circuit the operating mode for the controller of the domestic hot water charging (bringing forward the charging, operating the circulation pump, holiday function) should be taken into consideration.

- Local HCs: The domestic hot water charging only takes into consideration the separate heating circuits/cooling circuit inside the controller.
- All HCs in segment: The domestic hot water charging takes into consideration heating circuits/cooling circuit for the controller in the same segment.
- All HCs in system: The domestic hot water charging takes into consideration heating circuits/cooling circuit for all of the controllers in the system.



Important

For all settings, the controllers that are in holiday status are also taken into consideration for the DHW preparation.

■ Note OT limit ext source (6632)

Additional generators connected via the LBP can be locked or released according to their own parameter based on the outside temperature (e.g. air water heat pump). This status is distributed via LPB. The master thus knows via a cascade whether an additional generator (slave) is available according to its own application limits (outside temperature) or not, and can then connect it accordingly.

- No: The outdoor temperature limits of the external generator have been breached.
- Yes: The outdoor temperature limits of the external generator have been met.

■ Clock mode (6640)

This setting determines the effect of the system time on the controller time setting. The following settings are possible:

- Autonomously: The time can be adjusted at the controller. The time of the controller is not adapted to the system time.

- Slave without remote setting: The time cannot be adjusted at the controller. The controller time is constantly synchronised to the system time.
- Slave with remote setting: The time can be adjusted at the controller. The system time is synchronised simultaneously as the change is adopted by the master. The time of the controller is then continually adapted to the system time.
- Master: The time can be adjusted at the controller. The controller time is defaulted to the system. The system time is adapted.

■ Outside temp source (6650)

In the LPB system only one single outside temperature sensor is necessary. This delivers the signal via the LPB to the controllers without a sensor. The first figure in the display is the section number, the second is the appliance number.

9.2.19 Modbus

■ General

The Modbus interface can be used to connect to the control system or operating unit to exchange process and operating values.



See

You can find further information in the *Accessory instructions* for the Modbus interface.

9.2.20 Fault

■ Message (6700)

A current existing error in the system is displayed here in the form of an error code.

■ Display SW diagnostic code (6705)

In case of a fault, the display fault is on permanently. In addition, the diagnosis code is displayed on the display.

■ Burn ctrl phase lockout pos (6706)

Phase during which the fault occurred which led to the failure.

■ Reset alarm relay (6710)

An output relay QX, programmed as an alarm relay can be reset via this setting.

■ Flow temp 1 alarm (6740), Flow temp 2 alarm (6741), Flow temp 3 alarm (6742), Boiler temp alarm (6743), DHW charging alarm (6745)

Setting the time after which a fault message will be triggered in case of persisting deviation from temperature nominal and actual values.

■ Error history / Error codes (6800-6995)

The last 20 error messages with error codes and time of occurrence are saved to the error memory.

9.2.21 Maintenance / special operation

■ Burner hours interval (7040)

Setting of the interval for maintenance of the burner.

■ Burn hrs since maintenance (7041)

Burner hours since the last maintenance.

**Important**

The burner hours are only counted, when the maintenance message has been activated.

- **Burner start interval (7042)**

Setting of the interval for burner starts for maintenance.

- **Burn starts since maint (7043)**

Burner starts since the last maintenance.

**Important**

The burner starts are only counted, when the maintenance message has been activated.

- **Maintenance interval (7044)**

Setting of maintenance interval in months.

- **Time since maintenance (7045)**

Passed time since the last maintenance interval.

**Important**

The time is only counted, when the maintenance message has been activated.

- **Fan speed ionization current (7050)**

Speed limit from which the ionisation current service alarm should be set (prog. no. 7051), if the ionisation current monitoring and therefore a speed increase based on too low ionisation current active is.

- **Message ionization current (7051)**

Function for display and reset of the burner ionization current maintenance message. The maintenance message can only be reset if the reason for maintenance has been eliminated.

- **Chimney sweep function (7130)**

The chimney sweep function is switched on or off under this prog no.

**Important**

The function is switched off by the setting **Off** or automatically if the maximum boiler temperature is reached.
It can also be directly activated via the chimney sweep button.

- **Manual control (7140)**

Activation of manual control. If the manual control function is activated the boiler is controlled to the setpoint manual control. All the pumps are switched on. Additional request will be ignored!

- **Controller stop function (7143)**

If the controller stop function is activated, the burner output set in the setpoint controller stop is directly requested by the device.

- **Controller stop setpoint (7145)**

With activated controller stop function the output set here is requested by the device.

- **Compulsory heat draw-off DHW (7165)**

This parameter is used to set that heat pumping to the domestic hot water circuit takes priority when the chimney sweep function is active.

- Off: Compulsory pumping of the heat to the heating circuits.
- On: When the chimney sweep function is active, heat is pumped with priority into the domestic hot water circuit.

- **Commissioning wizard (7167)**

The commissioning wizard enables a guided configuration of the control (system configuration, functions, system settings, etc.).

■ Telephone customer service (7170)

Here the desired telephone number of customer service can be entered.

■ PStick storage pos (7250)

Via the parameter PStick storage pos the data set (data set number on the stick) can be selected which should be written or read.

If a data set is selected, the name of the data set is displayed bottom. For backup sticks the data set name is displayed in the format BUYMMDDHHMM (BU for backup and date of backup: Year, Month, Day, Hour, Minute). As soon as a data set number is selected, the text is displayed for the data set description.

■ PStick command (7252)

- No operation: This is the basic state. As long as no operation is active on the stick, this command is displayed.
- Reading from stick: Starts reading the data from the stick. This operation is only possible with READ sticks. The data of the set data set is copied to the LMS control. First a check is carried out as to whether the data set may be imported. If the data set is incompatible, it must not be imported. The display resets to No operation and displays an error message. The textReading from stick remains until the operation is completed or an error occurs. As soon as data transmission begins, the LMS control goes in a parameterization position. As soon as parameters are transferred, the LMS control must be unlocked transmission has ended. Fault 183 parameterization is displayed.
- Writing on stick: Starts writing the data from the LMS control to the stick. This operation is only possible with WRITE sticks. The data is written into the previously set data set. Before writing of the data begins, it is checked whether the stick has sufficient capacity for the data and that the respective customer number is correct. The textWriting on stick remains until the operation is completed or a fault occurs.

■ PStick progress (7253)

The read or write progress is displayed as a percentage. If no operation is active or a fault occurs, 0% is displayed.

The stick status is shown below:

- No stick: The LMS control has not detected a stick (the stick may not be inserted).
- Stick ready: Basic condition, stick is detected, no action active, no error present.
- Writing on stick: Data is copied (backup) from the LMS control to the stick.
- Reading from stick: Data is transferred from the stick to the LMS control.
- Writing error: An error occurred when copying the data from the LMS control to the stick. The operation was aborted.
- Reading error: An error occurred when copying the data from the stick to the LMS control.. The operation was aborted. The control LMS is locked. Status change to read lock.
- Incompatible data set: Data set does not match LMS control. Compatibility conditions are not met. The data set can not be imported.
- Wrong stick type: Stick type does not match selected action. E.g. reading from write stick or writing to read stick is not possible.
- Stick format error: Incorrect customer number on the stick or data format on the stick is unknown and cannot be evaluated by the LMS control.
- Check data set: During transmission of a data set from the stick to the LMS control a problem occurred, but it did not lead to an abort.
- Data set disabled: The data set may not be transferred into the LMS control (read protected).

9.2.22 Configuration of extension modules

■ Function extension module 1 (7300), Function extension module 2 (7375) and Function extension module 3 (7450)

When a function is selected, the inputs and outputs are occupied on the extension module with the functions according to the following table:

Connection terminal on module	QX21	QX22	QX23	BX21	BX22	H2/H21	H22
Multifunctional	*	*	*	*	*	*	*
Heating circuit 1	Y1	Y2	Q2	B1	*	*	*
Heating circuit 2	Y5	Y6	Q6	B12	*	*	*
Heating circuit 3	Y11	Y12	Q20	B14	*	*	*
Solar DHW	*	*	Q5	B6	B31	*	*
Primary contr/ system pump	Y19	Y20	Q14	B15	*	*	*
* Freely selectable in QX.../ BX... AVS75.390 = H2; AVS75.370 = H21							

Tab.19 Legend

Q2	1. Heating circuit pump
Q5	Collector pump
Q6	2. Heating circuit pump
Q14	System pump
Q20	Heating circuit pump HC3
Y1	1. Heating circuit mixer OPEN
Y2	1. Heating circuit mixer CLOSED
Y5	2. Heating circuit mixer OPEN
Y6	2. Heating circuit mixer CLOSED
Y11	3. Heating circuit mixer OPEN
Y12	3. Heating circuit mixer CLOSED
Y19	Primary control mixer OPEN
Y20	Primary control mixer CLOSED
B1	Flow sensor HC1
B6	Collector sensor
B12	Flow sensor HC2
B14	Flow sensor HC3
B15	Flow sensor primary control

■ Relay output QX21 module 1 (7301), Relay output QX22 module 1 (7302), Relay output QX23 module 1 (7303), Relay output QX21 module 2 (7376), Relay output QX22 module 2 (7377), Relay output QX23 module 2 (7378), Relay output QX21 module 3 (7451), Relay output QX22 module 3 (7452) and Relay output QX23 module 3 (7453)

- None: Relay outputs deactivated.
- Circulating pump Circulating pump Q4: The connected pump serves as DHW-circulating pump (see programme number 1660).
- El imm heater DHW K6: With the connected immersion heater, the DHW can be charged according to the operating side DHW storage operating line immersion heater.



Important

The operating mode is set under prog.no. 5060.

- Collector pump Q5: Connection of a circulating pump in case of solar collector use.

- Cons circuit pump VK1 Q15/Cons circuit pump VK2 Q18: Connection of a pump at the input Q15/18 for an additional consumer, which is requested via an Hx-input.
- Boiler pump Q1: the connected pump is used for recirculation of the boiler water.
- Alarm output K10: in case of a fault, this will be signalled by the alarm relay. The contact is closed with the delay time selected under prog. no. 6612. If no fault message exists, the contact opens without delay.



Important

The alarm relay can be reset without having the fault remedied (see prog. no. 6710). The alarm relay can also be closed temporarily by a message which, for example, leads to restart.

- Heat circuit pump HC3 Q20: Activating the pump heating circuit HC3.
- System pump Q14: Connection of a feed pump.
- Heat gen shutoff valve Y4: Connection of a changeover valve for hydraulic de-coupling of the heat generator from the rest of the heating system.
- Solid fuel boiler pump Q10: Connection of a circulation pump for the boiler circuit for the connection of a solid fuel boiler.
- Time program 5 K13: the relay will be controlled by the time program 5 according to the settings.
- Buffer return valve Y15: This valve must be configured for return temperature increase/decrease or the buffer storage tank partial charging.
- Solar pump ext exch K9: here, the solar pump external exchanger K9 must have been set for the external heat exchange.
- Solar ctrl elem buffer K8: if several exchangers are connected, the buffer storage must be set at the respective relay output and the type of solar regulating unit must be defined under prog.no.5840
- Solar ctrl elem swi pool K18: If several exchangers are connected, the swimming pool must be set at the respective relay output and the type of the solar regulating unit must be defined in prog.no. 5840.
- Swimming pool pump Q19: Connection of a swimming pool pump at the input Q19.
- Cascade pump Q25: Common boiler pump for all boilers in a cascade.
- St tank transfer pump Q11: the drinking water storage can be charged from the buffer storage, if is sufficiently hot. This transfer is brought about by transfer pump Q11.
- DHW mixing pump Q35: separate pump for storage circulation during active legionella function.
- DHW interm circ pump Q33: Charging pump for DHW cylinder with external heat exchanger.
- Heat request K27: as soon as a heat demand exists in the system, the output K27 will be activated.
- Heat circuit pump HC1 Q2/Heat circuit pump HC2 Q6: The relay is used for actuating the heating circuit pump Q2/Q6.
- DHW ctrl elem Q3: depending on the hydraulics a connected DHW charging pump or diverting valve.
- Status output K35: The status output is operated when a command exists from the controller to the burner control. If there is a disturbance, which prevents the burner control from operating, the status output is switched off.
- Status information K36: The output is set when the burner is in operation.
- Fan shutdown K38: This output serves to switch the fan off. The output is activated when the fan is needed; otherwise it is not activated. The fan should be switched off as often as possible in order to minimise the total energy consumption of the system.

■ **Sensor input BX21 module 1 (7307), Sensor input BX22 module 1 (7308), Sensor input BX21 module 2 (7382), Sensor**

input BX22 module 2 (7383), Sensor input BX21 module 3 (7457) and Sensor input BX22 module 3 (7458)

Functions in addition to the basic functions are made possible by configuring the sensor inputs.

- None: Sensor inputs deactivated.
- DHW sensor B31: Lower domestic water sensor, which is used for full charging of the Legionella function.
- Collector sensor B6: First solar collector sensor in a collector field.
- DHW circulation sensor B39: Sensor for DHW circulation return.
- Buffer sensor B4: Upper buffer storage tank sensor.
- Buffer sensor B41: Lower buffer storage tank sensor.
- Common flow sensor B10: Shared flow sensor for boiler cascades or low-loss header sensors.
- Solid fuel boiler sensor B22: Sensor for the acquisition of the temperature of a solid fuel boiler.
- DHW charging sensor B36: DHW sensor for DHW charging systems.
- Buffer sensor B42: Centre buffer storage tank sensor.
- Common return sensor B73: Return sensor for the return diversion function.
- Cascade return sensor B70: Common return sensor for boiler cascades.
- Swimming pool sensor B13: Sensor for measurement of swimming pool temperature.
- Solar flow sensor B63: This sensor is required for the solar yield measurement.
- Solar return sensor B64: This sensor is required for the solar yield measurement.

■ Function input H2/H21 module 1 (7321) , Function input H2/H21 module 2 (7396) and Function input H2/H21 module 3 (7471)

- None: no function.
- Optg mode change HCs+DHW: Changeover of the operating modes of the heating circuits to reduced or protection operation (prog.nos. 900, 1200, 1500) and locking of domestic hot water charging in case of closed contact at H2/H21.
- Optg mode changeover DHW: Locking of the domestic hot water charging in case of closed contact at H2/H21.
- Optg mode changeover HCs: Operating mode changeover for heating circuits to protection or reduced operation.



Important

Locking of domestic hot water charging is only possible under the setting **Optg mode change HCs+DHW**.

- Heat generation lock: the heat generator is locked through connecting terminal H2/H21. All temperature demands for heating circuits and DHW are ignored. The boiler frost protection function is maintained.



Important

The chimney sweeper function can be applied in spite of the heat generation lock.

- Error/alarm message: Closing the inputs Hx results in a control unit-internal fault message, which will also be signalled via a relay output programmed as an alarm output or in the remote management system.
- Consumer request VK1/Consumer request VK2: the set flow temperature setpoint is activated via the connecting terminals (e.g. a ventilation heater function for door curtain units).



Important

The setpoint must be set under progr. no. 1859/1909/1959.

- Release swi pool source heat: closing the input Hx (e.g. manual switch) enables the swimming pool heater. Heating is performed by means of 'heat generator heating'.

- Excess heat discharge: an active excess heat discharge enables, for example, an external source to force the consumers (heating circuit, DHW storage tank, heating circuit pump) to draw off the excess heat using a signal.
- Release swi pool solar: this function enables the solar swimming pool heater to be released externally (e.g. via a manual switch) or the solar charging priority to be specified as compared to the storage.
- Operating level DHW/HCs: The operating level can be set via the contact instead of via the internal time program (external time program).
- Ambient thermostat HCs: With the input a room thermostat request can be generated for the set heating circuit.



Important

The quick decrease should be switched off for the corresponding heating circuits.

- DHW thermostat: Connection of the DHW thermostat.
- Limit thermostat HC: If the extension module is used for the heating circuit, an external temperature monitor can be cut in at the inlet (e.g. for underfloor heating).
- Start prevention: With this input a burner start can be prevented.
- Consumer request VK1 10V/Consumer request VK2 10V: the application node external load x receives a voltage signal (DC 0-10 V) as heat request. The linear curve is defined via two fix points (input value 1/function value 1 and input value 2/function value 2).

■ **Contact type H2/H21 module 1 (7322), Contact type H2/H21 module 2 (7397) und Contact type H2/H21 module 3 (7472)**

With this function, the contact can be set as a normally closed contact (contact closed, must be opened to activate the function) or as a normally open contact (contact opened, must be closed to activate the function).

■ **Input and function values (7324-7327), (7399-7402) and (7474-7477)**

- F1 Function value 1
- F2 Function value 2
- S Voltage to Hx
- U1 Input value 1
- U2 Input value 2
- V Flow temperature setpoint

The linear sensor curve is defined over two fixed points. The setting is done with two parameter pairs for **function value** and **input value** (F1/U1 and F2/U2).

Fig.56 Example of heat demand 10 V

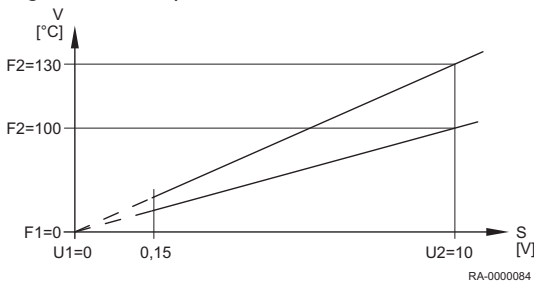

■ **Funct input EX21 module 1 (7342) , Funct input EX21 module 2 (7417) and Funct input EX21 module 3 (7492)**

- None: No function.
- Limit thermostat HC: If the extension module is used for the heating circuit, an external temperature monitor can be install in at the inlet EX21 (e.g. for underfloor heating). If the temperature monitor is activated: - The mixer is closed and the pump is switched off - A fault message is issued (temperature monitor HKx) - The status "Monitor activated is generated. If the function of the expansion module is set on heating circuit 1-3 and the function of input EX21 for the same module is set on the temperature monitor (HK), in this case, the status at input EX21 is taken into consideration internally for controlling the relay outputs (pump and mixer open/closed).

■ **Funct output UX21 module 1 (7348), Funct output UX22 module 1 (7355), Funct output UX21 module 2 (7423) und Funct output UX22 module 2 (7430), Funct output UX21 module 3 (7498) and Funct output UX22 module 3 (7505)**

- None: No function.

- Boiler pump Q1: The connected pump is used for recirculation of the boiler water.
- DHW pump Q3: Actuator for DHW storage tank.
- DHW interm circ pump Q33: Actuation of a charge pump for domestic hot water storage with external heat exchanger.
- Heat circuit pump HC1 Q2/Heat circuit pump HC2 Q6/Heat circuit pump HC3 Q20: Activation of the pump heating circuits HC1-HC3.
- Collector pump Q5: Actuation of a circulating pump when a solar collector is used.
- Solar pump ext exch K9: The solar circuit pump for the external heat exchanger K9 must be set here.
- Solar pump buffer K8: If several exchangers are connected, the buffer storage tank must be set at the respective relay output and the type of solar regulating unit must be defined under prog.no.5840.
- Solar pump swi pool K18: If several exchangers are connected, the swimming pool must be set at the respective output and the type of the solar regulating unit must be defined in prog.no. 5840.

■ **Sign logic out UX21 module1 (7349), Sign logic out UX22 module1 (7356), Sign logic out UX21 module2 (7424), Sign logic out UX22 module2 (7431), Sign logic out UX21 module3 (7499), Sign logic out UX22 module3 (7506)**

Output UX21/22 can be inverted when output if the output signal is configured as PWM. This means that variable-speed pumps can also be actuated using inverted signal logic

■ **Signal output UX21 module 1 (7350), Sign logic out UX22 module1 (7357), Signal output UX21 module 2 (7425) and Signal output UX22 module 2 (7432), Signal output UX21 module 3 (7500) und Signal output UX22 module 3 (7507)**

Specifies whether the signal is to be output as a 0 - 10 V signal or pulse-width modulated (PWM) signal.

9.2.23 Input/output test

■ **Input/output tests**

Tests for checking the function of connected components.

9.2.24 Status

■ **State**

With this function the status of the selected system can be requested.

Tab.20 Status table heating circuit

The following messages are possible under **Heating circuit**:

End user (Eu)	Commissioning, Engineer (menu Status)
Limiter has tripped	Limiter has tripped
Manual control active	Manual control active
Floor curing function active	Floor curing function active
Heating mode restricted	Overtemp prot active
	Restricted, boiler protection
	Restricted, DHW priority
	Restricted, buffer
Forced draw	Forced draw DHW
	Forced draw source
	Overrun active
Comfort heating mode	Opt start ctrl+boost heating
	Optimum start control

End user (Eu)	Commissioning, Engineer (menu Status)
	Boost heating
	Comfort heating mode
Reduced heating mode	Optimum stop control
	Reduced heating mode
Frost protection active	Frost prot room active
	Frost protection flow active
	Frost prot plant active
Summer operation	Summer operation
Off	24-hour Eco active
	Setback reduced
	Setback frost protection
	Room temp limitation
	Off

Tab.21 Status table domestic water

The following messages are possible under **Drinking water**:

End user (Eu)	Commissioning, Engineer (menu Status)
Limiter has tripped	Limiter has tripped
Manual control active	Manual control active
Consumption	Consumption
Keep hot mode on	Keep hot mode active
	Keep hot mode on
Recooling active	Recooling via collector
	Recooling via heat gen/HCs
	Recooling via DHW/HCs
Charging lock active	Discharging prot active
	Charg time limitation active
	Charging locked
Forced charging active	Forced, max st tank temp
	Forced, max charging temp
	Forced, legionella setp
	Forced, nominal setp
Push active	Push, legionella setp
	Push, nominal setp
Charging active	Charging, legionella setp
	Charging, nominal setp
	Charging, reduced setp
Frost protection active	Frost protection active
	Frost prot instant WH
Overrun active	Overrun active
Standby charging	Standby charging
Charged	Charged, max st tank temp
	Charged, max charging temp
	Charged, legionella temp
	Charged, nominal temp
	Charged, reduced temp
Off	Off
Ready	Ready

Tab.22 Status table boiler

The following messages are possible under **Boiler**:

End user (Eu)	Commissioning, Engineer (menu Status)
SLT has tripped	SLT has tripped
Fault	Fault
Limiter has tripped	Limiter has tripped
Manual control active	Manual control active
Chimney sweep funct active	Chim sweep fct, high-fire
	Chim sweep fct, low-fire
Locked	Locked, manual
	Locked, solid fuel boiler
	Locked, automatic
	Locked, outside temp
	Locked, Economy mode
Min limitation active	Min limitation
	Min limitation, low-fire
	Min limitation active
In operation	Protective start
	Protective start, low-fire
	Return limitation
	Return limitation, low-fire
Charging buffer	Charging buffer
In part load op for HC, DHW	In part load op for HC, DHW
In part load op for HC, DHW	In part load op for HC, DHW
Released for HC, DHW	Released for HC, DHW
In operation for DHW	In operation for DHW
In part load op for DHW	In part load op for DHW
Released for DHW	Released for DHW
In operation for HC	In operation for HC
In part load op for HC	In part load op for HC
Released for HC	Released for HC
Overrun active	Overrun active
Released	Released
Frost protection active	Frost protection active
Off	Off

Tab.23 Status table solar

The following messages are possible under **Solar**:

End user (Eu)	Commissioning, Engineer (menu Status)
Manual control active	Manual control active
Fault	Fault
Frost prot collector active	Frost prot collector active
Recooling active	Recooling active
Max st tank temp reached	Max st tank temp reached
Evaporation prot active	Evaporation prot active
Overtemp prot active	Overtemp prot active
Max charging temp reached	Max charging temp reached
Charging DHW	Charging DHW
Radiation insufficient	Min charg temp not reached

End user (Eu)	Commissioning, Engineer (menu Status)
	Temp diff insufficient
	Radiation insufficient

Tab.24 Status table solid fuel boiler

The following messages are possible under **Solid fuel boiler**:

End user (Eu)	Commissioning, Engineer (menu Status)
Manual control active	Manual control active
Fault	Fault
Overtemp prot active	Overtemp prot active
Released	Locked, manual
	Locked, automatic
Min limitation active	Min limitation
	Min limitation, low-fire
	Min limitation active
In operation for HC	Protective start
	Protective start, low-fire
	Return limitation
	Return limitation, low-fire
	In operation for HC
In part load op for HC	In part load op for HC
In operation for DHW	In operation for DHW
In part load op for DHW	In part load op for DHW
In op for HC, DHW	In op for HC, DHW
In part load op for HC, DHW	In part load op for HC, DHW
Overrun active	Overrun active
In operation	In operation
Assisted firing active	Assisted firing active
Released	Released
Frost protection active	Frost prot plant active
	Boiler frost prot active
Off	Off

Tab.25 Status table burners

The following messages are possible under **Burner**:

End user (Eu)	Commissioning, Engineer (menu Status)
Lockout position	Lockout position
Start prevention	Start prevention
In operation	In operation
Startup	Safety time
	Prepurge
	Startup
	Postpurge
	Shutdown
	Home run
Standby	Standby

Tab.26 State table buffer storage tank

The following messages are possible under **Buffer storage tank**:

End user (Eu)	Commissioning, Engineer (menu Status)
Hot	Hot
Frost protection active	Frost protection active
Charg el imm heater	El charg, emergency mode
	El charg, source protection
	Electric charging defrost
	Electric charging, forced
	Electric charging, substitute
Charging restricted	Charging locked
	Restricted, DHW priority
Charging active	Forced charging active
	Partial charging active
Recooling active	Recooling via collector
	Recooling via DHW/HCs
Charged	Charged, max st tank temp
	Charged, max charging temp
	Charged, forced temp
	Charged, required temp
	Part charged, required temp
	Charged, min charging temp
Cold	Cold
No request	No request

Tab.27 Status table swimming pool

The following messages are possible under **Swimming pool**:

End user (Eu)	Commissioning, Engineer (menu Status)
Manual control active	Manual control active
Fault	Fault
Heating mode restricted	Heating mode source
Heated, max swi pool temp	Heated, max swi pool temp
Heated	Heated, setpoint solar
	Heated, setpoint source
Heating mode	Heating mode solar off
	Heating mode source off
Cold	Cold

9.2.25 Diagnostics cascade/heat generation/consumers

■ Diagnostics cascade/heat generation/consumers (8100-9058)

Displays of different setpoint and actual values, relay switching statuses and counter statuses for diagnostics purposes.

■ Gas energy

There are 6 energy meters available, comprising the estimated gas energy used with the aid of the fan speed and a linear approximation of the actual burner output. The energy meters must be switched on and off using prog.no. 2550. The results can be corrected under prog.no. 2551.

- 2 overall meters can be reset on the engineer level:
 - Prog.no. 8378: Total gas energy heating
 - Prog.no. 8379: Total gas energy DHW
- The end consumer can reset 2 meters:
 - Prog.no. 8381: Gas energy heating
 - Prog.no. 8382: Gas energy DHW

**Important**

Prog.no. 8380 and 8383 are the result of adding the previous parameters.

9.2.26 Burner control

■ **Prepurge time (9500)**

Pre-venting time.

**Caution**

This parameter must only be changed by a heating specialist!

■ **Required output prepurging (9504)**

Nominal output fan speed during preventing.

■ **Required output ignition (9512)**

Nominal output fan speed during ignition.

■ **Required output LF (9524)**

Nominal output fan speed under boiler in part load.

**Important**

If you change this value, please note that prog.no. 2452 (Controller delay fan output) is always higher.

■ **Required output HF (9529)**

Nominal output fan speed under boiler in HF

■ **Postpurge time (9540)**

After-venting time.

**Caution**

This parameter must only be changed by a heating specialist!

■ **Fan output/speed slope (9626) and Fan output/speed Y-section (9627)**

The speed of the fan can be adjusted with this. This is important for complex installations or change to LPG.

- Prog 9626 corresponds to the slope of the fan curve
- Prog 9627 corresponds to the displacement of the fan curve in Y-direction

9.2.27 Info option

Different information values are displayed depending on the operating conditions. In addition, information about the status is displayed.

10 Maintenance

10.1 General

10.1.1 General instructions

In heating and air conditioning systems, a regular inspection and maintenance as required by qualified personnel contribute to correct operation according to the product specification, and therefore to ensuring high efficiency and low environmental pollution in the long term.



Danger of electric shock

Before any work, switch off the mains supply to the boiler. Before removing parts of the casing, the boiler has to be de-energised.

Work under voltage (removed casing) may only be carried out by a trained electrician.

Cleaning of heating surfaces and burner should be carried out by the approved installer. Before work is started, the gas shut-off device and the disconnecter valves of the hot water should be closed.



Danger Risk of poisoning.

Never use condensate water as drinking water!

- Condensate is not suitable for consumption by people or animals.
- Do not let the skin come into contact with condensate.
- Suitable protective clothing must be worn during maintenance work.

10.1.2 Inspection and service as required



Important

We recommend having the boiler inspected annually. If the need for maintenance work is found during inspection, this should be carried out according to need.

Maintenance work includes:

- Cleaning the boiler outside.
- The burner must be checked for soiling, and then cleaned and serviced if necessary.
- Clean burner areas and heating surfaces
- Checking connection and seal locations of water filled parts
- Replacing wear parts (see *Spare parts list*)



Caution

Only original spare parts may be used!

- Check safety valves for correct function.
- Check operating pressure and, possibly, fill in water
- Bleed the heating system and return the gravity lock to operating position.
- Final check and documentation of performed service work



See

More detailed information about the inspection and service of heat generators is included in BDH/ZVSHK Info sheet 14.



Important

In order to guarantee optimum operation of the heat pump we recommend concluding a service contract.

10.1.3 Lifetime of safety-relevant components

Safety-relevant components (e.g. gas valves) have a limited lifetime that mainly depends on the operating years and the operating cycles. The remaining lifetime of individual safety-relevant components can be determined as part of maintenance work carried out by an approved installer. If the lifetime Potterton in accordance with the following table is exceeded, recommends replacing the relevant components.

Safety-relevant components	Design-related rated lifetime	
	Operating cycles	Years
Gas pressure monitor	50.000	10
Air pressure monitor	250.000	10
Gas valve		
EC five 400 kW - 540 kW	500.000	10
EC five 610 kW	100.000	10



Important

The number of operating cycles can be read under *Start counter 1st stage* (prog. no. 8331) in the menu item *Diagnostics heat generation*.

10.2 Maintenance messages

10.2.1 Maintenance message

If the maintenance sign appears in the display  a maintenance message exists or the system is in special operation.

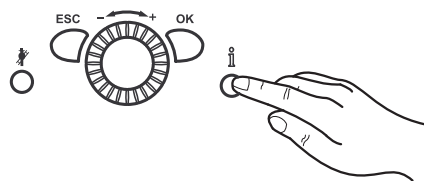
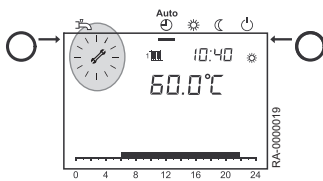

1. Press the **information key**.
⇒ Further information is displayed.



See
Maintenance code table



Important

The maintenance message has not been activated by the setting in the factory.

10.2.2 Maintenance code table

Servicing code	Maintenance description
1:Burner hours run	Burner operating hours exceeded
2:Number of burner starts	Burner starts exceeded
3:Maintenance interval	Maintenance interval exceeded

10.2.3 Operating phases of the Control Centre LMS

The operating phases are displayed after the **information key** has been pressed.

Phase number		
Display	Operating state	Description of function
STY	Standby (no heat demands)	Burner on stand-by
THL1	Fan start-up	Self-test for burner start and fan start-up
THL1A		
TV	Pre-purging time	Pre-purging, fan deceleration time to starting load speed
TBRE	Waiting time	Internal safety tests
TW1		
TW2		
VDE	Ignition phase	Ignition and start of safety time for flame formation, ionisation current build-up
TSA1	Safety time constant	Flame monitoring with ignition
TSA2	Safety time variable	Flame monitoring without ignition
TI	Interval time	Flame stabilisation
MOD	Modulating mode	Operating burner
THL2	Subsequent ventilation with last operating fan speed	Fan continues to run
THL2A	Subsequent ventilation with pre-purging fan speed	Fan continues to run
TNB	Burner shut-off delay	Permitted burner run-on time
TNN	Overrun time	Permitted fan run-on time
STV	Start prevention	No internal or external release exists (e.g. no water pressure, lack of gas)
SAF	Safety switch-off	
STOE	Fault position	The current fault mode is displayed.

10.3 Standard inspection and maintenance operations

10.3.1 Checking water hardness

The water hardness of the heating water has to be checked within the scope of the recommended maintenance of the boiler and the corresponding amount of additive has to be added if necessary.

10.3.2 Cleaning the fan



Danger of electric shock
Danger to life due to electric current!

Before service work is started, the boiler has to be de-energised and secured from accidentally being switched back on.

The following steps describe how to remove and clean the fan.

1. Remove front cladding and front side cladding
2. Lift the control box upwards and keep hold of it
3. Secure the control box with a lock
4. Remove all connection plugs on the top of the fan

Fig.57 Lifting the control box upwards

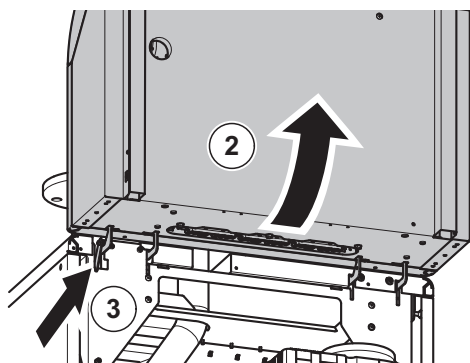

RA-0000270

Fig.58 Loosening the screwed connections

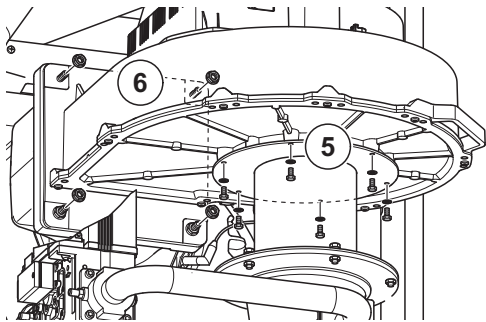

RA-0000271

5. Loosen the screws on the connection piece to the venturi tube on the bottom of the fan
6. Remove connection screws to the mixing adapter

Fig.59 Removing the fan

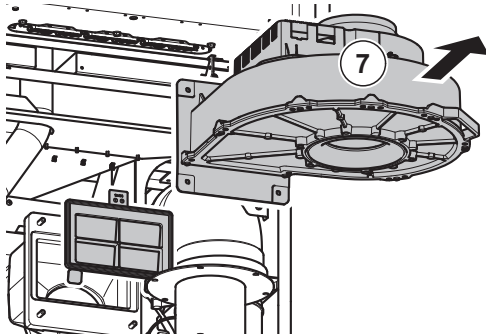

RA-0000272

7. Remove fan with air flap
8. Check the fan for function
9. Clean the fan with compressed air
10. Reinstall the fan in the reverse sequence

10.3.3 Cleaning the burner pipe



Danger of electric shock
Risk of death from electric current!

Before performing service work, power to the boiler must be shut off and it must be secured from accidentally being switched back on!

1. Remove front cladding and front side cladding
2. Fold the control box upwards and secure it with lock (see section *Cleaning the fan*)
3. Remove the fan (see section *Cleaning the fan*)
4. Loosen nuts and remove the mixing adapter with seal

Fig.60 Removing the mixing adapter

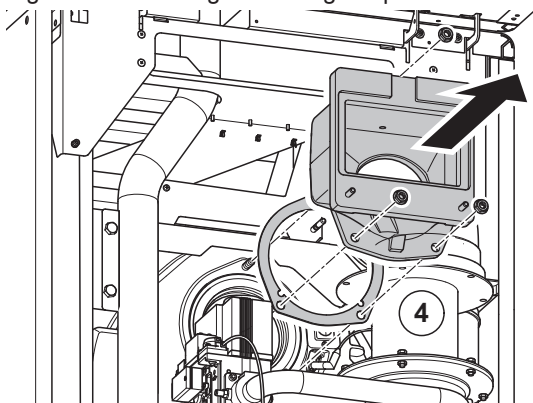

RA-0000300

Fig.61 Removing the burner pipe

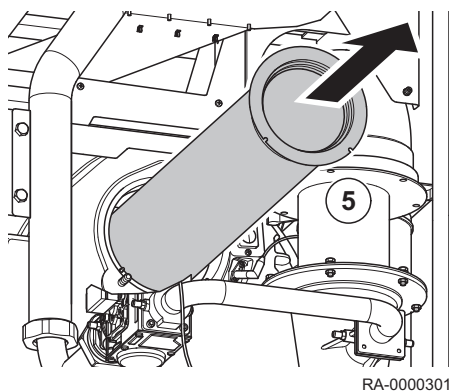

RA-0000301

5. Pull the burner pipe out of the opening
6. Clean the burner pipe with compressed air

Fig.62 Replacing the cover plate and the insulation

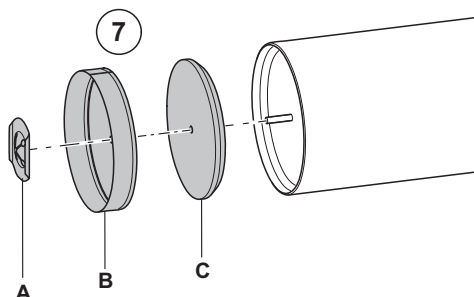

RA-0001588

7. In the event of a defect, remove retaining clip, replace cover plate and insulation

- A Retaining clip
- B Cover plate
- C Insulation

The Installation is done in reverse order.

Fig.63 Install the burner pipe

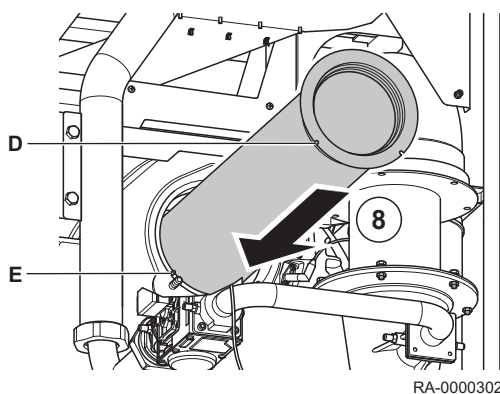

RA-0000302

8. Reinstall the burner pipe

i Important
Make sure the burner pipe is installed straight. The metal pins on the opening of the front heat exchanger element must be located in the recesses of the burner pipe. In addition the end of the burner pipe must lie on the rear heat exchanger element.

- D Recesses in the burner pipe
- E Metal pins on the opening of the front heat exchanger element

9. Reinstall the mixing adapter and fan

i Important
When installing the mixing adapter use a new seal.

For more information, see
Cleaning the fan, page 143

10.3.4 Checking and replacing ignition and ionization electrode



Danger of electric shock
Danger to life due to electric current!

Before service work is started, the boiler has to be de-energised and secured from accidentally being switched back on.

1. Remove front cladding and front side cladding
2. Lift the control box upwards and secure with a lock (see *Cleaning the fan* section)
3. Disconnect ignition wire on the ignition transformer

Fig.64 Removing the ignition and ionization electrode

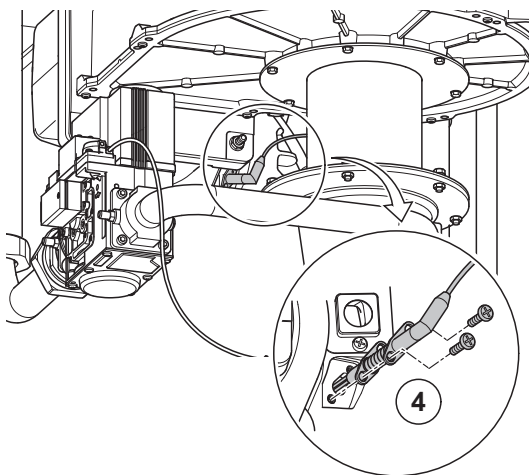

RA-0000298

- Loosen the screws and remove the ignition and ionization electrode with seal

Fig.65 Electrode spacing

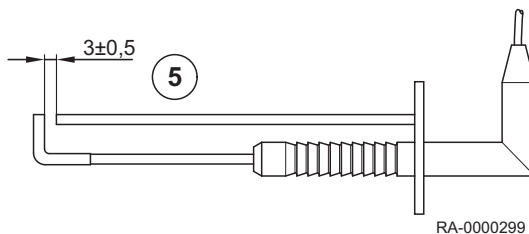

RA-0000299

- Check the setting of the ignition and ionization electrode

i Important
The electrode spacing must be 3 ± 0.5 mm (see Fig.)

- If necessary, install new ignition and ionization electrode in the reverse sequence

i Important
When installing the ignition and ionization electrode use a new seal.

- Connect the ignition wire of the new ignition and ionization electrode to the ignition transformer

For more information, see
Cleaning the fan, page 143

10.3.5 Cleaning the heat exchanger and siphon

⚡ Danger of electric shock
Danger to life due to electric current!
Before service work is started, the boiler has to be de-energised and secured from accidentally being switched back on.

Fig.66 Removing the insulation panel

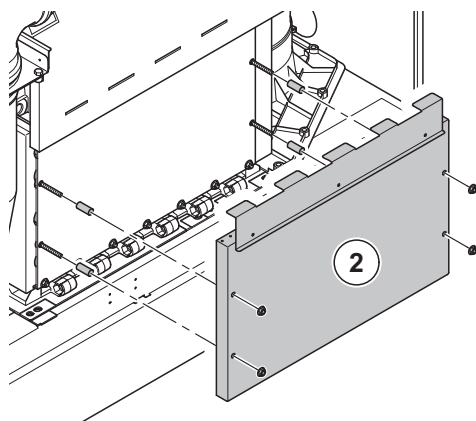

RA-0000303

- Remove the cladding front wall and entire right side cladding
- Loosen nuts and remove the insulation panel with spacer sleeves

Fig.67 Removing the inspection cover

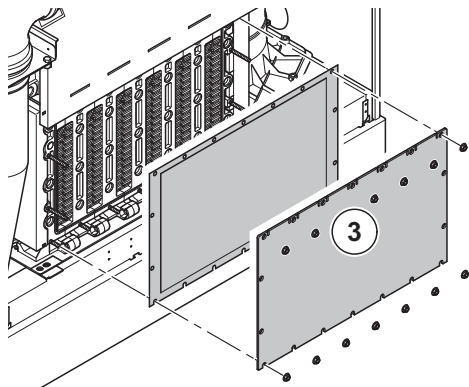

RA-0000304

3. Loosen nuts and remove the inspection cover with seal

Fig.68 Dry cleaning the heat exchanger

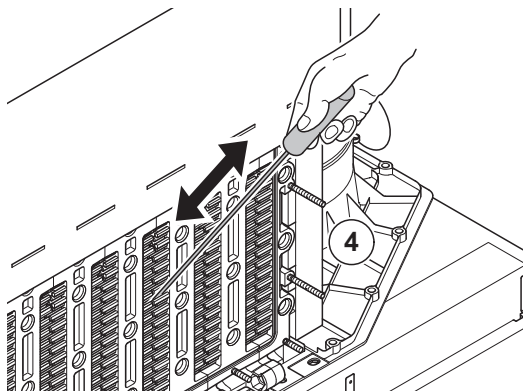

RA-0000305

4. Clean the heat exchanger with the cleaning rod (accessory) **horizontally and vertically**
5. Remove the fan, mixing adapter and burner pipe (see sections *Cleaning the fan* and *Cleaning the burner pipe*)
6. Reinstall the inspection cover with seal and insulation panel

**Danger****Risk of life due to escaping flue gas!**

A damaged seal can lead to flue gas escaping. For this reason, any damaged seals must be replaced.

Fig.69 Wet cleaning the heat exchanger

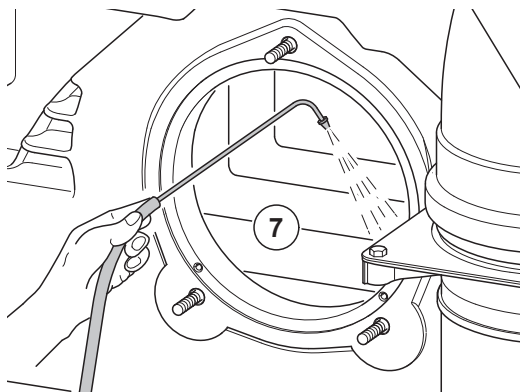

RA-0000306

7. Spray the heat exchanger through the burner opening from inside with gas boiler cleaning agent

**Danger****Risk of poisoning and chemical burns!**

Protective gloves and safety goggles or a face shield must be worn when using gas boiler cleaning agents. The surroundings must be protected from escaping cleaning agent. In addition the safety and disposal information from the cleaning agent manufacturer must be followed.

8. Rinse off dirt residue with water in the condensate trough
9. Reinstall the burner pipe, mixing adapter and fan

Fig.70 Remove the cap

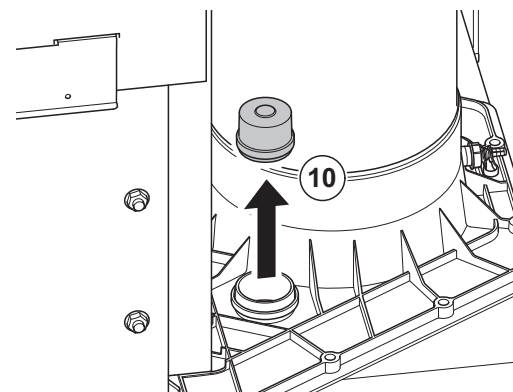

RA-0000307

10. Remove the cap from the condensate trough

**Important**

On the opposite side of the flue gas connection there is another cap.

Fig.71 Rinsing the condensate trough

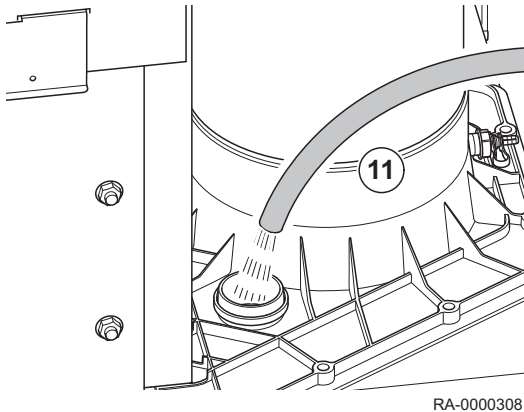

RA-0000308

11. Rinse out the condensate trough with water through the opening

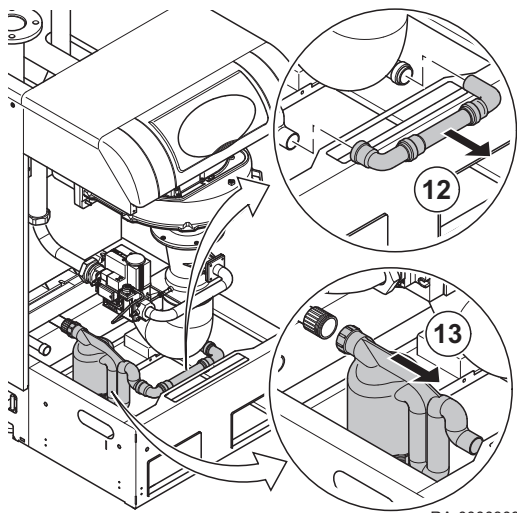

RA-0000309

- 12. Remove pipe connection
- 13. Loosen the screwed connection on the condensate connection and remove the siphon
- 14. Rinse out the siphon with clear water and reinstall in the reverse order



Danger

Risk of life due to escaping flue gas!

Before installing the siphon and commissioning of the gas condensing boiler, fill the siphon with approx. 1 l water.

- 15. Check the condensate piping for leaks
- 16. Reinstall the side cladding and cladding front wall

10.3.6 Checking CO₂ content

The CO₂ content must be checked within the scope of maintenance and be adjusted in accordance with the details in *Adjusting CO₂ content* if necessary.



For more information, see

- Adjusting CO₂ content, page 60
- CO₂ content at max. output (EC five 400 kW - 540 kW), page 60
- CO₂ content at min. output (EC five 400 kW - 540 kW), page 60
- CO₂ content at max. output (EC five 610 kW), page 61
- CO₂ content at min. output (EC five 610 kW), page 61

10.3.7 Checking air pressure monitor pipes

All air pressure monitor pipes must be checked, and disconnected and cleaned with compressed air if necessary.



Important

If the air pressure monitor pipes are disconnected during maintenance work, they must be reconnected based on the schematic drawing in the section *Description of the function of the air pressure monitor*.



For more information, see

- Description of the function of the air pressure monitor, page 22

10.3.8 Filling the system



Danger
Risk of burns!
 Water-carrying pipes get hot!

Only top up with heating water that is of domestic water quality. Chemical additives must not be used.



Important
 Observe the following sequence in order to prevent the water pressure increasing in the hose.

1. Turn the EC five off at the operating switch
2. Make sure that the disconnecter valves for heating return (HR) and heating flow (HV) on the top of the EC five have been opened

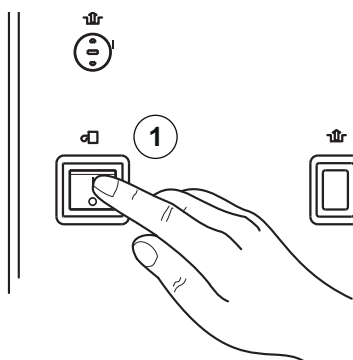

RA-0000348

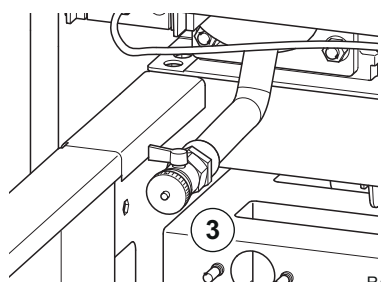

RA-0000349

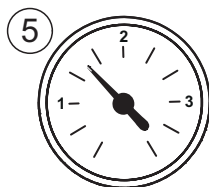

RA-0000201

3. Remove the protective cap from the boiler fill and drain valve (BFD valve) on the return manifold of the EC five and screw the hose nozzle in place
4. Push the water hose onto the hose nozzle

5. First open the filling and drain valve, then slowly open the water tap. The value should be between 1.0 and 2.5 bar.
6. First close the water tap, then close the fill and drain valve
7. Remove water hose
8. Place the protective cap back onto fill and drain valve
9. Turn the EC five on again at the operating switch
10. Control the heating system for leaks



Important
 If radiators do not get hot: Bleed the radiators.

10.3.9 Maintenance of the accessories

In the scope of the service, installed accessories (wall ducts, air filters, etc.) must also be checked for soiling and be cleaned if necessary.



See
 The Installation instructions of the installed accessories must be followed during maintenance of the accessories.

11 Troubleshooting

11.1 Fault code table

The following is an extract from the fault code table. If other fault codes are displayed, please inform the installer.

Fault code	Error description	Explanations/causes
0	No fault	
10	Outside temp sensor fault	Check connection or outside temp sensor, emergency operation
20	Boiler temperature 1 sensor fault	Check connection, inform heating specialist ⁽¹⁾
25	Boiler temperature solid fuel sensor fault	
26	Boiler temperature solid fuel sensor fault	
28	Boiler temperature solid fuel sensor fault	
30	Flow temperature 1 sensor fault	
32	Flow temperature 2 sensor fault	Check connection, inform heating specialist ⁽¹⁾
38	Boiler temperature solid fuel sensor fault	
40	Return temperature 1 sensor fault	Check connection, inform heating specialist ⁽¹⁾
46	Boiler temperature solid fuel sensor fault	
47	Common return temp sensor fault	
50	DHW temperature 1 sensor fault	Check connection, inform heating specialist, emergency operation ⁽¹⁾
52	DHW temperature 2 sensor fault	Check connection, inform heating specialist ⁽¹⁾
54	Flow temperature DHW sensor fault	
57	Drinking water circulation temperature sensor fault	
60	Room temperature 1 sensor fault	
65	Room temperature 2 sensor fault	
68	Room temperature 3 sensor fault	
70	Storage tank temp 1 (top) sensor fault	
71	Storage tank temp 2 (bottom) sensor fault	
72	Storage tank temp 3 (middle) sensor fault	
73	Collector temperature 1 sensor fault	
81	LPB short-circuit or no bus power supply	
82	LPB address collision	Check addresses of connected control modules
83	BSB wire short-circuit	Check connection of the room units
84	BSB address collision	2 room devices have the same assignment (prog.no. 42)
85	BSB wireless commissioning fault	
91	EEPROM fault: information of locking mechanism	Internal fault LMS, process sensor, replace LMS, heating specialist
98	Expansion module 1 fault (collective fault)	
99	Expansion module 2 fault (collective fault)	
100	Two time masters (LPB)	Check time master
102	Clock time master without backup	
105	Maintenance message	See maintenance code (press information button once) for detailed information
109	Boiler temperature monitoring	
110	Safety temperature limiter lockout	No heat removal, faulty sensor, STB/interruption, possible short circuit in the gas valve ⁽²⁾ , internal fuse faulty; allow device to cool down and carry out reset; if the fault occurs several times inform the installer ⁽³⁾
111	Temperature monitor switching off	No heat supply; pump defect, radiator valves closed ⁽¹⁾
121	Flow temperature 1 (Heating circuit 1) monitoring	
122	Flow temperature 2 (Heating circuit 2) monitoring	
126	DHW charging monitoring	

Fault code	Error description	Explanations/causes
127	Legionnaire's disease germs temperature not reached	
128	Flame failure during operation	
132	Gas pressure Monitor fault or air pressure monitor fault	Lack of gas, contact GW opened, external temperature monitor
133	No flame during the safety time	Reset, if the fault re-occurs several times contact installer, lack of gas, polarity of mains connection, safety period, check ignition electrode and ionization current ⁽¹⁾⁽³⁾
146	Configuration fault common message	
151	Internal fault	Check parameters (see adjustment table installer and/or call-up values), unlock LMS, replace LMS, installer ⁽¹⁾⁽³⁾
152	Parameterization fault	
153	Boiler was manually locked	Restart the boiler by pressing the "Reset" key 
160	Fan fault	Fan possible defective, speed threshold set wrongly ⁽³⁾
162	Air pressure monitor does not close	
171	Alarm contact H1 or H4 activated	
172	Alarm contact H2 (EM1, EM2 or EM3) or H5 activated	
178	Temperature monitor heating circuit 1	
179	Temperature monitor heating circuit 2	
183	The device is in parameter setting mode	
217	Sensor fault	
218	Pressure monitoring	
241	Flow sensor solar sensor fault	
242	Return sensor solar sensor fault	
243	Swimming pool sensor fault	
260	Flow temperature 3 sensor fault	
270	Monitoring function	
317	Mains frequency outside of valid range	
320	DHW charging temp sensor fault	
322	Water pressure too high	Check the water pressure and drain water if required ⁽¹⁾
323	Water pressure too low	Check the water pressure and top up water if required ⁽¹⁾
324	BX same sensors	
325	BX / extension module same sensors	
326	BX / mixer group same sensors	
327	Extension module same function	
328	Mixer group same function	
329	Extension module / mixer group same function	
330	Sensor BX1 no function	
331	Sensor BX2 no function	
332	Sensor BX3 no function	
335	Sensor BX21 no function (EM1, EM2 or EM3)	
336	Sensor BX22 no function (EM1, EM2 or EM3)	
339	Collector pump Q5 missing	
341	Collector sensor B6 missing	
342	Solar DHW sensor B31 missing	
343	Solar interconnection missing	
344	Solar actuator buffer K8 missing	
345	Solar actuator swimming pool K18 missing	
346	Solid fuel boiler pump Q10 missing	
347	Solid fuel boiler comp sensor missing	
348	Solid fuel boiler address error	
349	Storage buffer return valve Y15 missing	

Fault code	Error description	Explanations/causes
350	Storage buffer address error	
351	Primary controller/supply pump address error	
352	Low-loss header address error	
353	Common flow sensor B10 missing	
371	Flow temperature 3 (Heating circuit 3) monitoring	
372	Temperature monitor HK3	
373	Expansion module 3 fault (collective fault)	
378	Repetition counter internal fault expired	
382	Repetition counter fan fault expired	
384	External light	
385	Mains undervoltage	
386	Fan speed has left valid range	
387	Air pressure switch fault	
426	Feedback flue damper	
427	Configuration flue damper	
432	Functional earth X17 not connected	
(1) Switch off, start prevention, re-start after elimination of fault (2) Check parameter in accordance with table Check the installer adjustment table and program to the basic settings or query internal LMS SW diagnosis code and correct the corresponding parameter faults according to fault specification (3) switch-off and locking; can only be unlocked by reset		

11.2 Fault finding

11.2.1 Fault message

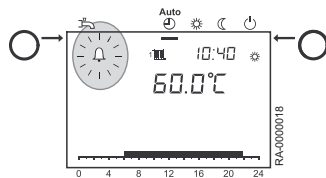

If the fault symbol appears on the display  there is a fault in the heating system.

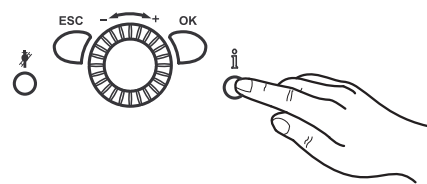

1. Press the **information key**.
 ⇒ Further information about the fault is displayed

 **See**
Fault code table

11.2.2 Fault switch-off

A fault switch-off is a safety-switch off in the case of flame failure during operation. After every safety switch-off a new ignition attempt is carried out as per program. If this does not result in flame formation a fault switch-off occurs.

In case of fault switch-off, the reset button on the control panel should be pressed.

In case of operation disturbances (bell symbol in the display), the digit in the display on the operating panel indicates the cause of the disturbance (see fault code table).

Burner does not start:

- No voltage at the control and regulating centre
- No "burner ON" signal from the heating circuit control (see *Fault code table*)
- Gas tap closed
- No ignition

Burner goes into fault mode:

Without flame formation:

- No ignition
- Ionization electrode has ground connection
- Ionization electrode is not connected
- No gas
- Gas pressure too low

In spite of flame formation the burner goes into fault mode after expiration of the safety time:

- Ionization electrode defective or soiled
- Ionization electrode does not penetrate the flame
- Ionization electrode is not connected
- Gas pressure not stable

12 Decommissioning

12.1 Decommissioning procedure

12.1.1 Decommissioning the domestic water storage tank

Caution
Risk of water damage!

Ensure the stored water can flow unimpeded into the drain.

The domestic water storage tank is decommissioned as follows:

1. Close the disconnecter valve to stop the cold water supply.
2. Open the drain valve on the drinking water storage tank.
3. Vent the domestic water storage tank
4. Put the heat generator out of operation.

12.1.2 Draining off the heating water



Danger
Risk of burns!

Water-carrying pipes get hot!

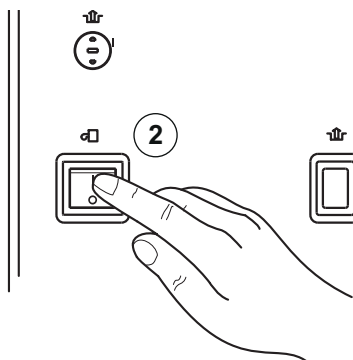
1. Close gas shut off device
2. Turn off the gas condensing boiler at the ON/OFF switch
3. Turn off the mains isolator
4. Close the disconnecter valves for heating return (HR) and heating flow (HV) on the top of the EC five. The EC five is isolated from the heating network.

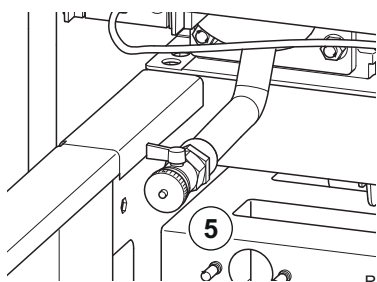

RA-0000350



RA-0000351

5. Remove the protective cap from the boiler fill and drain valve on the return manifold of the EC five and screw the hose nozzle to the boiler fill and drain valve
6. Connect a hose to the nozzle of the boiler's filling and drain valve.

Caution

Care must be taken to ensure that the hose is seated firmly on the hose nozzle before the filling and drain valve is opened.

7. Place a bucket or other drip pan underneath
8. Open the BDF valve, the boiler water drains out

Caution
Risk of damage to the boiler!

Prevent the appliance from being switched back on while there is no water in the heating system, e.g. by sticking tape over the ON/OFF switch. Otherwise the pumps will overheat and be destroyed.

13 Disposal/recycling

13.1 Packaging

As part of the packaging regulations, Potterton provides local disposal facilities for the specialist company to ensure correct recycling of all the packaging. In order to protect the environment, the packaging is 100% recyclable.

**See**

Please follow the legal requirements applicable to disposal in your country.

13.2 Appliance disposal

The appliance can be returned to Potterton for disposal via a specialist company. The manufacturer undertakes to recycle the appliance correctly.

**Important**

The appliance is recycled by a disposal company. If possible, the materials, especially the plastics, are identified. This enables correct sorting for recycling.

14 Appendix

14.1 Declaration of conformity



EU-Declaration of conformity No. 2018/078

Product	Condensing gas boiler
Trade Mark	EuroCondense
Product ID number	CE-0085 CL 0072
Type, Model	EuroCondense five 125, EuroCondense five 170, EuroCondense five 215, EuroCondense five 260, EuroCondense five 300
EU Directives EU Regulations	(EU)2016/426, 92/42/EG, 2009/125/EG, (EU)2017/1369, (EU)811/2013, (EU)813/2013, 2014/30/EU, 2014/35/EU
Standards	DIN EN 15502-1:2015-10; DIN EN 15502-2-1:2017-09; EN 13203-2:2015-08 DIN EN 60335-1:2012-10; EN 60335-1:2012 DIN EN 60335-1 Ber.1:2014-04; EN 60335-1:2012/AC:2014 EN 60335-1:2012/A11:2014 DIN EN 60335-2-102:2010-07; EN 60335-2-102:2006+A1:2010 DIN EN 62233:2008-11; EN 62233:2008 DIN EN 62233 Ber. 1:2009-04; EN 62233 Ber.1:2008 DIN EN 55014-1:2012-05; EN 55014-1:2006 + A1:2009 + A2:2011 DIN EN 55022:2011-12; EN 55022:2010 Port remote control DIN EN 61000-3-2:2015-03; EN 61000-3-2:2014 DIN EN 61000-3-3:2014-03; EN 61000-3-3:2013 DIN EN 55014-2:2009-06; EN 55014-2:1997 + A1:2001 + A2:2008 Requirements of the category II
EC Type Examination	TÜV Rheinland Energie GmbH Am Grauen Stein 51105 Köln
Surveillance Procedure	Module D EG Gas Appliance Regulation (EU)2016/426 DVGW CERT GmbH D-53123 Bonn

The producer states the following:

The above named products fulfil the requirements of the directives, regulations and standards. They are identical with the prototype examined. The production process follows the guidelines of the surveillance procedure. The above named products are only for installations in hot water heating systems. The installer has to assure that the directives for installation and operation are being followed.

ppa. S. Harms

Technical Director
-AUGUST BRÖTJE GmbH-

21.04.2018

i. V. U. Patzke

Test Laboratory Manager and
Delegate for Documentation
-AUGUST BRÖTJE GmbH-

Potterton Commercial
Innovation House
3 Oaklands Business Centre
Oaklands Park
Wokingham
Berkshire
RG412FD
Telephone: +44 (0345) 070 1057
www.pottertoncommercial.co.uk

Index

A	
Additives	28
Air pressure monitor	22
Antifreeze agent	30
Application examples	40
Automatic day heating limit	65
Automatic operation	65
Automatic summer/winter changeover	65
B	
Bleed the radiators	149
Blowpipe of the safety valve	61
Boiler	46
- Levelling	46
- Positioning	46
Burner cleaning	141
C	
Cable lengths	55
Changing settings	63
Check tightness	53,54
Chimney sweep function	67
Clean siphon	148
Clean the heat exchanger	147
Cleaning and inspection openings	54
Cleaning the fan	143
Combustion supply air	32
Comfort setpoint	66
Condensate	52
Continuous mode	65
Controller stop function	59
D	
Disconnecter valve	53
Disconnecter valves	64,141
Disposal	155
Domestic water mode	66
Domestic water temperature	101
E	
ECO function	24
Emergency operation	66
Emergency switch	54,64
Extension modules	25
F	
Factory setting	91,125
Factory settings	67
Fault code table	150
Fault message	24,152
Fault switch-off	152
Frost protection setpoint	24,65
G	
Gas connection	53
Gas filter	53
H	
Heating mode	65
Heating water quality	27
I	
INFO	24
Inlet and outlet air openings	49,51
Installation room	32
Intended use	9
L	
Language	59
Leak-tightness	149
Legionella function	66
M	
Maintenance	141
Maintenance contract	141
Maintenance message	24,142
Manual adjustment of burner output	59
Manual control	66,129
N	
Neutralisation equipment	52
O	
Operating phases	142
Optimum start and stop control	98
Outdoor temperature sensor	55
Outside temperature sensor	16
P	
Packaging	155
Protection against contact	56
Protection mode	65
Q	
Quick reduction	97
R	
Recycling	155
Reduced setpoint	66
Reduced setpoint increase	98
Regulations	13
Resistance values	16
Room temperature	66
- Comfort setpoint	66
- Reduced setpoint	66
S	
Safety valve	52
Setting the curve	94
Setting the heating curve	94
Standards	13
Summer/winter heating limit	95
System log	62
T	
Technical data	14
Tip on energy-saving; circulating pump	102
Top up heating water	149
W	
Water hardness	143
Water pressure	64

© Copyright

All technical and technological information contained in these technical instructions, as well as any drawings and technical descriptions supplied, remain our property and shall not be multiplied without our prior consent in writing. Subject to alterations.

Potterton Commercial Part of Baxi Heating UK Ltd | Brooks House,
Coventry Road, Warwick, CV34 4LL | Phone 0345 070 1055 |
www.pottertoncommercial.co.uk

