

Installation Manual

Gas condensing boiler

Paramount five 30
Paramount five 40
Paramount five 50
Paramount five 60
Paramount five 80
Paramount five 95
Paramount five 115

Dear Customer,

Thank you very much for buying this appliance.

Please read through the manual carefully before using the product, and keep it in a safe place for later reference. In order to ensure continued safe and efficient operation we recommend that the product is serviced regularly. Our service and customer service organisation can assist with this.

We hope you enjoy years of problem-free operation with the product.

Contents

1	Safety	6
1.1	General safety instructions	6
1.2	Intended use	8
1.3	Specific safety instructions	9
1.3.1	Liquid gas below ground level	9
1.4	Liabilities	9
1.4.1	Manufacturer's liability	9
1.4.2	Manufacturer's Declaration	9
1.4.3	Installer's liability	10
1.4.4	User's liability	10
2	About this manual	11
2.1	General	11
2.2	Additional documentation	11
2.2.1	Additional documentation	11
2.3	Symbols used	11
2.3.1	Symbols used in the manual	11
3	Technical specifications	13
3.1	Homologations	13
3.1.1	Regulations and standards	13
3.2	Technical data	13
3.2.1	Technical data – Boiler space heaters	13
3.2.2	Technical data – Boiler space heaters	14
3.2.3	Technical data	15
3.2.4	Tables of sensor values	16
3.2.5	Total dynamic head Paramount	17
3.3	Dimensions and connections	18
3.4	Dimensions and connections	20
3.5	Wiring diagram	21
4	Description of the product	24
4.1	Main components	24
4.2	Control panel description	25
4.2.1	Operating elements	25
4.2.2	Displays	26
4.3	Standard delivery	26
4.4	Accessories & options	26
4.4.1	Room device RGP	26
4.4.2	Installation of extension module	27
5	Before installation	28
5.1	Regulations governing installation	28
5.2	Installation requirements	28
5.2.1	Corrosion protection	28
5.2.2	Supply air openings	28
5.2.3	Treating and preparing the heating water	28
5.2.4	Heating water requirements	29
5.2.5	Determining the system volume	32
5.2.6	Practical information for qualified heating specialists	32
5.2.7	Use of antifreeze agents with Potterton Commercial heat generators	32
5.3	Choice of the location	34
5.3.1	Requirements for the installation room	34
5.3.2	Notes for installation location	35
5.3.3	Operation in bath and shower rooms	35
5.4	Transport	36
5.4.1	General	36
5.5	Unpacking	37
6	Installation	38
6.1	General	38
6.2	Hydraulic connections	38
6.2.1	Connecting the heating circuit	38
6.2.2	Safety valve	38

6.2.3	Connecting the expansion vessel	38
6.2.4	Condensate	39
6.2.5	Sealing and filling of the system	39
6.3	Gas connection	39
6.3.1	Gas connection	39
6.3.2	Venting the gas line	39
6.4	Air supply/flue gas outlet connections	40
6.4.1	System certification	40
6.4.2	Flue gas connection	40
6.4.3	Permissible flue gas pipe lengths	41
6.4.4	Power compensation for increasing the permissible flue gas piping lengths	42
6.4.5	General information about the exhaust gas piping system	42
6.4.6	Mounting the flue gas system	43
6.4.7	Outlets	45
6.4.8	Chimneys already in use	46
6.4.9	Cleaning and inspection openings	46
6.5	Electrical connections	46
6.5.1	Electrical connection (general)	46
6.5.2	Cable lengths	47
6.5.3	Strain reliefs	47
6.5.4	Replacing cables	47
6.5.5	Protection against contact	48
6.5.6	IP rating IPx4D	48
6.5.7	Circulating pumps	48
6.5.8	Appliance fuses	48
6.5.9	Connecting sensors/components	48
7	Commissioning	49
7.1	General	49
7.2	Checklist for commissioning	49
7.3	Commissioning procedure	50
7.3.1	Checking that the pump is running normally	50
7.3.2	Commissioning menu	50
7.4	Gas settings	50
7.4.1	Factory settings	50
7.4.2	Supply pressure	50
7.4.3	CO ₂ content	51
7.4.4	Changing over from natural gas to LPG and vice versa	51
7.4.5	Gas valve	52
7.4.6	Manual adjustment of burner output (controller stop function)	52
7.4.7	Guidance values for gas flow rate, injector pressure and CO ₂ content	53
7.4.8	Guidance values for the gas flow rate	53
7.4.9	Guidance values for the gas flow rate	54
7.4.10	Guidance values for injector pressure	54
7.4.11	Guidance values for injector pressure	54
8	Operation	56
8.1	Changing parameters	56
8.2	Programming procedure	57
8.3	Checking water pressure	57
8.4	Checking the domestic water storage tank	57
8.5	Preparing start-up	57
8.6	Setting the heating mode	58
8.7	Adjusting domestic water mode	58
8.8	Adjusting comfortable room setpoint	59
8.9	Setting reduced room setpoint	59
8.10	Pump setting (pumped heating circuit)	59
8.11	Emergency mode (Manual control)	61
8.12	Chimney sweep function	61
9	Settings	62
9.1	List of parameters	62
9.2	Description of the parameters	84
9.2.1	Time and date	84
9.2.2	Operator section	84
9.2.3	Wireless	86

9.2.4	Time programs	86
9.2.5	Holiday programs	87
9.2.6	Heating circuits	87
9.2.7	Domestic water	95
9.2.8	Consumer circuits/swimming pool circuit	97
9.2.9	Swimming pool	98
9.2.10	Primary control/feed pump	99
9.2.11	Boiler	99
9.2.12	Cascade	103
9.2.13	Solar	104
9.2.14	Solid fuel boiler	107
9.2.15	Buffer storage tank	108
9.2.16	DHW storage tank	110
9.2.17	Configuration	115
9.2.18	LPB system	123
9.2.19	Modbus	125
9.2.20	Fault	125
9.2.21	Maintenance / special operation	125
9.2.22	Configuration of extension modules	127
9.2.23	Input/output test	132
9.2.24	Status	132
9.2.25	Diagnostics cascade/heat generation/consumers	136
9.2.26	Burner control	137
9.2.27	Info option	137
10	Maintenance	139
10.1	General	139
10.1.1	General instructions	139
10.1.2	Inspection and service as required	139
10.1.3	Lifetime of safety-relevant components	140
10.1.4	Protection against contact	140
10.1.5	Approved detergents	140
10.1.6	Unhooking the control panel	141
10.1.7	At the end of the maintenance work	141
10.2	Maintenance messages	141
10.2.1	Maintenance code table	141
10.2.2	Operating phases of the Control Centre LMS	141
10.3	Standard inspection and maintenance operations	142
10.3.1	Clean siphon	142
10.3.2	Check electrodes	143
10.4	Specific maintenance operations	143
10.4.1	Replacing air vent	143
10.4.2	Removing and installing the gas burner	143
10.4.3	Removing gas valve	145
10.4.4	Removing the heat exchanger	145
11	Troubleshooting	147
11.1	Error codes	147
11.1.1	Fault code table	147
11.2	Fault finding	149
11.2.1	Fault switch-off	149
12	Disposal	151
12.1	Disposal/recycling	151
12.1.1	Packaging	151
12.1.2	Appliance disposal	151
13	Appendix	152
13.1	Declaration of conformity	152
13.1.1	Declaration of conformity	152
	Index	153

1 Safety

1.1 General safety instructions



Danger

If you smell gas:

1. Do not use a naked flame, do not smoke, do not operate electrical contacts or switches (doorbell, light, motor, lift, etc.).
2. Shut off the gas supply.
3. Open the windows.
4. Trace possible leaks and seal them immediately.
5. If the gas leak is before the gas meter, contact the gas supplier.



Danger

Danger to life.

Observe the warnings affixed to the gas condensing boiler. Incorrect operation of the gas condensing boiler can lead to considerable damage.



Warning

Persons involved in transport must wear protective gloves and safety footwear.



Danger

Commissioning may only be carried out by an approved installer. The installer checks the tightness of pipes, the correct function of all regulating, control and safety equipment, and measures the combustion values. If this work is not carried out correctly, there is a risk of considerable damage to persons, environment and property.



Danger

Risk of poisoning.

Never use water from the heating system as drinking water. It is contaminated by deposits.

**Danger****Risk of poisoning.**

Never use condensate water as drinking water!

- Condensate is not suitable for consumption by people or animals.
- Do not let the skin come into contact with condensate.
- Suitable protective clothing must be worn during maintenance work.

**Caution****Danger of freezing!**

If there is a danger of freezing do not shut down the heating system; continue to operate it at least in economy mode with radiator valves open. You should only shut down the heating system and drain the boiler, domestic water storage tank and radiators if it is not possible to heat in frost mode.

**Caution****Secure against unintentional switch-on!**

When the heating system is empty, ensure that the boiler cannot be switched on unintentionally.

**Danger**

This appliance can be used by children aged from 8 years and above and persons with reduced physical, sensory or mental capabilities or lack of experience and knowledge if they have been given supervision or instruction concerning use of the appliance in a safe way and understand the hazards involved. Children shall not play with the appliance. Cleaning and user maintenance shall not be made by children without supervision.

**Danger**

The heating system must not continue to be operated if damaged!

**Danger****Risk of death due to modifications to the boiler!**

Unauthorised conversions and modifications to the boiler are not permitted, as these can put people at risk and cause damage to the boiler. Failure to comply with these instructions renders the approval for the boiler void.



Danger

Replacement of damaged parts may only be performed by an installer.



Warning

Risk of damage!

The condensing boiler may only be installed in rooms with clean combustion air. Foreign matter such as pollen must never filter through the inlet apertures to reach the inside of the appliance. The boiler must not be started up if there is heavy dust development e.g. during construction work. There could be damage to the boiler.



Caution

Keep the inflow area clear.

Never block or close off ventilation apertures. The inflow area for combustion air must be kept clear.



Danger

Danger to life due to explosion/fire.

Do not store any explosive or easily flammable materials close to the appliance.



Caution

Risk of burns!

For safety reasons, the discharge pipe from the safety valve must always be open so that water can escape during heating operation. The operating state of the safety valve must be checked from time to time.

1.2 Intended use

The gas condensing boilers of the Paramount series are intended to be used according to DIN EN 12828 as heat generators in domestic water heating systems.

They conform to DIN EN 15502-1.

1.3 Specific safety instructions

1.3.1 Liquid gas below ground level

The Paramount complies with DIN EN 126 and DIN EN 298 and, therefore does not need an additional disconnecter valve for operation with liquid gas below ground level.

1.4 Liabilities

1.4.1 Manufacturer's liability

Our products are manufactured in compliance with the requirements of the various Directives applicable. They are therefore delivered with the CE marking and any documents necessary. In the interests of the quality of our products, we strive constantly to improve them. We therefore reserve the right to modify the specifications given in this document.

Our liability as manufacturer may not be invoked in the following cases:

- Failure to abide by the instructions on installing and maintaining the appliance.
- Failure to abide by the instructions on using the appliance.
- Faulty or insufficient maintenance of the appliance.

1.4.2 Manufacturer's Declaration

Meeting the protection requirements according to guideline 2014/30/EU for electromagnetic compatibility (EMC) is only guaranteed when the boiler is operated according to purpose.

The ambient conditions must be complied with as per EN 55014.

Operation is only allowed with the casing fitted correctly.

Correct electric earthing must be ensured by regular checks (e.g. annual inspection) of the boiler.

When appliance parts need replacing, only original parts as specified by the manufacturer may be used.

The gas condensing-boilers fulfil the basic requirements of the Efficiency Guideline 92/42/EC as condensing boiler.

When natural gas is used, the gas condensing-boiler emit less than $60^{\text{mg}}/\text{kWh}$ NO_x corresponding to the requirements as per §6 of the Ordinance regarding small firing places dated 26.01.2010 (1. BImSchV).

1.4.3 Installer's liability

The installer is responsible for the installation and initial commissioning of the appliance. The installer must observe the following instructions:

- Read and follow the instructions given in the manuals provided with the appliance.
- Install the appliance in compliance with prevailing legislation and standards.
- Carry out initial commissioning and any checks necessary.
- Explain the installation to the user.
- If maintenance is necessary, warn the user of the obligation to check the appliance and keep it in good working order.
- Give all the instruction manuals to the user.

1.4.4 User's liability

To guarantee optimum operation of the system, you must abide by the following instructions:

- Read and follow the instructions given in the manuals provided with the appliance.
- Call on a qualified professional to carry out installation and initial commissioning.
- Get your installer to explain your installation to you.
- Have the required inspections and maintenance carried out by a qualified installer.
- Keep the instruction manuals in good condition close to the appliance.

2 About this manual

2.1 General

This manual is intended for the installer of a Paramount boiler.

2.2 Additional documentation

2.2.1 Additional documentation

Here is an overview of the further documents belonging to this heating system.

Tab.1 Overview table

Documentation	Contents	Intended for
Technical information	<ul style="list-style-type: none"> • Planning documents • Description of function • Technical data/circuit diagrams • Basic equipment and accessories • Application examples • Call-for-tender texts 	Planner, installer, customer
Installation manual – Extended information	<ul style="list-style-type: none"> • Intended use • Technical data/circuit diagram • Regulations, standards, CE • Notes for installation location • Application example, Standard application • Commissioning, operation and programming • Maintenance 	Installer
User manual	<ul style="list-style-type: none"> • Commissioning • Operation • User settings/programming • Fault table • Cleaning/maintenance • Energy-saving tips 	Customer
Asset ledger	<ul style="list-style-type: none"> • Commissioning report • Check list for commissioning • Maintenance 	Installer
Abridged instructions	<ul style="list-style-type: none"> • Operation in brief 	Customer
Accessories	<ul style="list-style-type: none"> • Installation • Operation 	Installer, customer

2.3 Symbols used

2.3.1 Symbols used in the manual

This manual uses various danger levels to draw attention to special instructions. We do this to improve user safety, to prevent problems and to guarantee correct operation of the appliance.



Danger

Risk of dangerous situations that may result in serious personal injury.



Danger of electric shock

Risk of electric shock.



Warning

Risk of dangerous situations that may result in minor personal injury.



Caution

Risk of material damage.



Important

Please note: important information.



See

Reference to other manuals or pages in this manual.

3 Technical specifications

3.1 Homologations

3.1.1 Regulations and standards

Beside the general technical rules, the relevant standards, regulations, ordinances and guidelines should be followed:

- DIN 4109: Sound insulation in buildings
- DIN EN 12828: Heating systems in buildings –, planning domestic hot water heating systems
- Federal Immission Control Ordinance 1. BImSchV
- DVGW-TRGI 1986 (DVGW-worksheet G 600): Technical Rules for gas installation
- TRF: Technical Rules LPG
- DVGW-Data sheet G - 613 Gas appliances- Installation, maintenance and operating instructions
- DIN 18380: Installation of central heating systems and hot water supply systems (VOB)
- DIN EN 12831: Heating systems in buildings -, Method for calculation of the design heat load
- DIN 4753: Domestic hot water calorifiers. Domestic hot water heating system and storage tanks for heated water
- DIN 1988: Technical rules for drinking water installations (TRW)
- DIN EN 60335-2-102: Safety of electrical appliances for household use and similar purposes: Special requirements for gas-, oil- und solid fuel appliances with electrical connections
- Fuel Ordinance, State Ordinances
- Regulations of the local Electricity Board
- Obligation to register (possibly. Group Exemption Regulation)
- ATV-Code-of-practice M251 of the waste water technology association
- Regulations of the public authorities for the run-off of condensate.

3.2 Technical data

3.2.1 Technical data – Boiler space heaters

Tab.2 Technical parameters for boiler space heaters

Model			Paramount 30	Paramount 40
Condensing boiler			Yes	Yes
Low-temperature boiler ⁽¹⁾			No	No
B1 boiler			No	No
Cogeneration space heater			No	No
Combination heater			No	No
Rated heat output	P_{rated}	kW	29	37
Useful heat output at rated heat output and high temperature mode ⁽²⁾	P_4	kW	29.2	37.0
Useful heat output at 30% of rated heat output and low temperature mode ⁽¹⁾	P_1	kW	9.8	12.4
Seasonal space heating energy efficiency	η_s	%	93	93
Useful efficiency at rated heat output and high temperature mode ⁽²⁾⁽²⁾	η_4	%	87.6	87.7
Useful heat output at 30 % of rated heat output and low temperature mode ⁽¹⁾	η_1	%	97.9	97,8
Auxiliary electricity consumption				
At full load	el_{max}	kW	0.055	0.070
At part load	el_{min}	kW	0.021	0.025
In standby mode	P_{SB}	kW	0.003	0.003

Model			Paramount 30	Paramount 40
Other data				
Standby heat loss	P_{stby}	kW	0.055	0.055
Ignition burner power consumption	P_{ign}	kW	0.0	0.0
Annual energy consumption	Q_{HE}	GJ	91	115
Sound power level, indoors	L_{WA}	dB	51	54
Emissions of nitrogen oxides	NO _x	mg/kWh	23	23
(1) Low temperature means for condensing boilers 30°C, for low temperature boilers 37°C and for other heaters 50°C return temperature (at heater inlet).				
(2) High temperature mode means 60°C return temperature at heater inlet and 80°C feed temperature at heater outlet.				



See

Contact details on the back cover.

3.2.2 Technical data – Boiler space heaters

Tab.3 Technical parameters for boiler space heaters

Model			Paramount 50	Paramount 60	Paramount 80	Paramount 95	Paramount 115
Condensing boiler			Yes	Yes	Yes	Yes	Yes
Low-temperature boiler ⁽¹⁾			No	No	No	No	No
B1 boiler			No	No	No	No	No
Cogeneration space heater			No	No	No	No	No
Combination heater			No	No	No	No	No
Rated heat output	P_{rated}	kW	49	56	75	93	112
Useful heat output at rated heat output and high temperature mode ⁽²⁾	P_4	kW	48.7	56.4	74.9	92.5	111.7
Useful heat output at 30% of rated heat output and low temperature mode ⁽¹⁾	P_1	kW	16.3	18.9	25.1	31.0	37.4
Seasonal space heating energy efficiency	η_s	%	93	93	–	–	–
Useful efficiency at rated heat output and high temperature mode ⁽²⁾	η_4	%	87.7	87.7	87.7	87.8	87.6
Useful heat output at 30% of rated heat output and low temperature mode ⁽¹⁾	η_1	%	97.8	97,8	97,8	98,0	97,8
Auxiliary power consumption							
At full load	el_{max}	kW	0.088	0.100	0.112	0.170	0.200
At part load	el_{min}	kW	0,028	0,029	0.030	0,029	0.030
In standby mode	P_{SB}	kW	0.003	0.003	0.003	0.003	0.003
Other data							
Standby heat loss	P_{stby}	kW	0.060	0.060	0.065	0.070	0.070
Ignition burner power consumption	P_{ign}	kW	0.0	0.0	0.0	0.0	0.0
Annual energy consumption	Q_{HE}	GJ	151	175	–	–	–
Sound power level, indoors	L_{WA}	dB	56	55	55	58	60
Emissions of nitrogen oxides	NO _x	mg/kWh	18	21	23	25	30
(1) Low temperature means for condensing boilers 30°C, for low temperature boilers 37°C and for other heaters 50°C return temperature (at heater inlet).							
(2) High temperature mode means 60°C return temperature at heater inlet and 80°C feed temperature at heater outlet.							



See

Contact details on the back cover.

3.2.3 Technical data

Tab.4 Technical data

Model				Para- mount 30	Para- mount 40	Para- mount 50	Para- mount 60	Para- mount 80	Para- mount 95	Para- mount 115
Product ID no.				CE-0085BL0514						
IP rating				IPx4D						
Gas category				II ₂ H ₃ +						
Appliance category				B ₂₃ , B _{23P} , B ₃₃ , C _{13X} , C _{33X} , C _{43X} , C ₅₃ , C _{53X} , C _{63X} , C ₈₃ , C _{93X}						
Software version				V 4.6						
Nominal input range	Natural gas E, LL	Heating mode	kW	5,6 - 30,0	9,0 - 38,0	10,0 - 50,0	14,0 - 58,0	21,0 - 77,0	20,0 - 95,0	25,0 - 115,0
Effective rated output range	Natural gas E, LL	80/60°C	kW	5,4 - 29,2	8,7 - 37,0	9,7 - 48,7	13,6 - 56,4	20,3 - 74,9	19,4 - 92,5	24,3 - 111,7
		50/30°C	kW	6,0 - 31,2	9,7 - 39,6	10,8 - 52,1	15,1 - 60,4	22,6 - 80,2	21,4 - 98,6	26,7 - 119,3
Standard operating efficiency		75/60°C		106						
pH value condensate			-	4 - 5	4 - 5	4-5	4-5	4-5	4 - 5	4 - 5
Volume condensate		40/30°C	l/h	0,83 - 3,00	1,19 - 2,84	1,60 - 4,68	1,78 - 4,71	2,53 - 6,46	2,75 - 8,42	3,85 - 9,61
NO _x concentration, weighted in accordance with EN 15502			mg/k Wh	23	23	23	21	23	25	30
NO _x class in accordance with EN 15502			-	6	6	6	6	6	6	6
Data for design of the chimney to DIN EN 13384 (room air-depending operation)										
Flue gas temperature	Part load/full load	80/60°C	°C	53/66	56/75	58/69	59/71	59/73	59/73	60/77
	Part load/full load	50/30°C	°C	33/46	35/53	33/50	34/54	35/54	32/51	33/57
Flue gas mass flow rate	Natural gas E, LL	80/60°C	g/s	2,8 - 14,8	4,4 - 18,7	4,9 - 24,6	6,9 - 28,5	10,3 - 37,9	9,8 - 46,7	12,3 - 56,6
		50/30°C	g/s	2,5 - 14,1	4,1 - 18,0	4,5 - 23,5	6,4 - 27,4	9,7 - 36,4	9,1 - 44,8	11,3 - 54,4
Flue gas mass flow rate	Propane	80/60°C	g/s	2,6 - 14,1	4,2 - 17,8	5,6 - 23,5	6,6 - 27,2	9,8 - 36,1	14,1 - 44,6	16,4 - 53,9
		50/30°C	g/s	2,4 - 13,4	3,9 - 17,1	5,2 - 22,4	6,1 - 26,1	9,2 - 34,6	13,3 - 42,6	15,4 - 51,7
CO ₂ content natural gas	Natural gas E, LL		%	Paramount 30 - Paramount 60: 8,3 - 8,8 Paramount 80 - 115: 8,5 - 9,0						
CO ₂ content LPG	Propane		%	10,3 - 10,8						
Draft requirement			mbar	0						
Max. delivery pressure at flue gas outlet			mbar	1,1	1,1	1,1	1,1	1,1	1,5	1,8
Flue gas/air supply duct			mm	110 / 160						
Flue gas value group to DVGW G636			-	G6						
Heating water										
Adjustment range heating water temperature			°C	20 - 85	20 - 85	20 - 85	20 - 85	20 - 85	20 - 85	20 - 85
Max. flow temperature			°C	85						
Operating pressure	min.		bar	1,0	1,0	1,0	1,0	1,0	1,0	1,0
			MPa	0,1	0,1	0,1	0,1	0,1	0,1	0,1
	max.		bar	3,0	3,0	6,0	6,0	6,0	6,0	6,0
			MPa	0,3	0,3	0,6	0,6	0,6	0,6	0,6
Gas-connected loads										
Supply pressure for natural gas			mbar	G20: min. 17 - max. 25						

Model			Para- mount 30	Para- mount 40	Para- mount 50	Para- mount 60	Para- mount 80	Para- mount 95	Para- mount 115
Connection values	Natural gas E [H _{UB} 9,45 kWh/m ³]	m ³ /h	0,59 - 3,2	0,95 - 4,0	1,06 - 5,30	1,48 - 6,10	2,22 - 8,10	2,12 - 10,10	2,65 - 12,20
	Natural gas LL [H _{UB} 8,13 kWh/m ³]	m ³ /h	0,69 - 3,7	1,11 - 4,7	1,23 - 6,20	1,72 - 7,10	2,58 - 9,50	2,46 - 11,70	3,08 - 14,10
Connection pressure for propane		mbar	min. 25 - max. 45						
	Propane [H _U 12,87 kWh/kg]	kg/h	0,44 - 2,33	0,70 - 2,95	0,93 - 3,89	1,09 - 4,51	1,63 - 5,98	2,33 - 7,38	2,72 - 8,94
	Propane [H _U 24.64 kWh/m ³]	m ³ /h	0,23 - 1,22	0,37 - 1,54	0,49 - 2,03	0,57 - 2,35	0,85 - 3,13	1,22 - 3,86	1,42 - 4,67
Electrical power consumption									
Electrical connection		V/Hz	230 V / 50 Hz						
Max. electr. power consumption		W	55	70	88	100	112	170	200
Heating mode	Protection	W	3	3	3	3	3	3	3
Dimensions									
Weight of boiler		kg	53	53	61	61	72	84	84
Boiler water content		l	3,6	3,6	4,7	4,7	5,8	7,8	7,8
Height		mm	852						
Width		mm	480						
Depth		mm	407	407	447	447	542	570	570
Connections									
Gas connection			3/4"			1"			
Heating flow			1"			1 1/2"			
Heating return			1"			1 1/2"			



For more information, see

Power compensation for increasing the permissible flue gas piping lengths, page 42

3.2.4 Tables of sensor values

Tab.5 Resistance values for outside temperature sensor ATF

Temperature [°C]	Resistance [Ω]
-20	8194
-15	6256
-10	4825
-5	3758
0	2954
5	2342
10	1872
15	1508
20	1224
25	1000
30	823

Tab.6 Resistance values for flow sensor KVF, drinking water sensor TWF, return sensor KRF, Buffer sensor B41

Temperature [°C]	Resistance [Ω]
0	32555
5	25339
10	19873

Temperature [°C]	Resistance [Ω]
15	15699
20	12488
25	10000
30	8059
35	6535
40	5330
45	4372
50	3605
55	2989
60	2490
65	2084
70	1753
75	1481
80	1256
85	1070
90	915
95	786
100	677

3.2.5 Total dynamic head Paramount

Fig.1 Total dynamic head Paramount 30 - Paramount 40

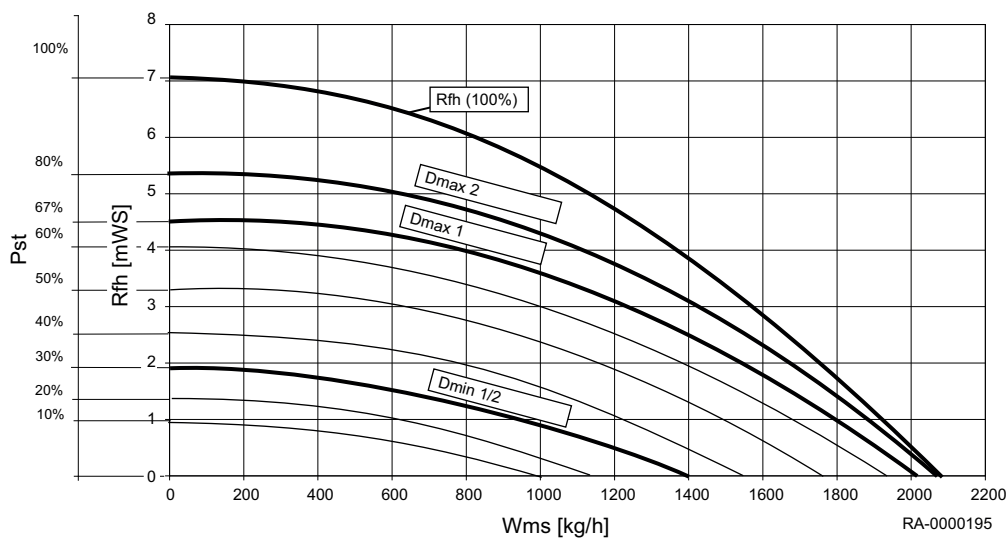

Key:	
Dmax 1	Paramount 30 (max.)
Dmax 2	Paramount 40 (max.)
Dmin 1/2	Paramount 30 (min.) Paramount 40 (min.)
Pst	Pumping stage
Rfh	Total dynamic head
Wms	Water mass flow



Important

The select min. and max. values are controlled via the program numbers for minimum pump speed and maximum pump speed.

3.3 Dimensions and connections

Fig.2 Dimensions and connections Paramount 30 / 40

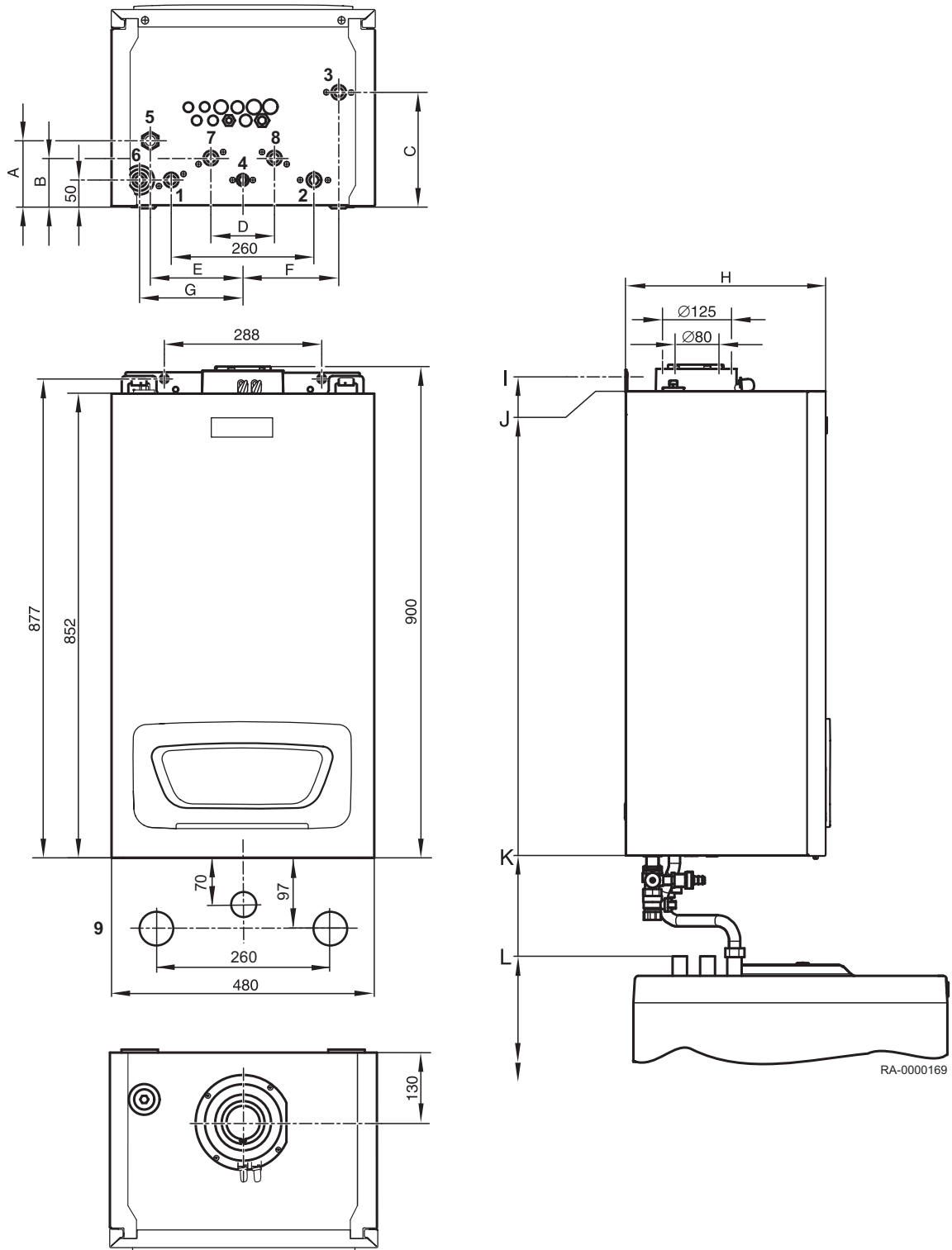



- 1 HV – Heating flow
- 2 HR – Heating return
- 3 2. HR – Heating return, heating circuit 2
- 4 Gas – Gas connection
- 5 SiV – Safety valve
- 6 KA – Condensate connection
- 7 SV – Storage tank flow (accessory)
- 8 SR – Storage tank return (accessory)

Tab.7 Dimensions and connections

Model		Paramount 30/40
HV – Heating flow		G 1"
HR – Heating return		G 1"

Model		Paramount 30/40
2nd HR – Heating return, heating circuit 2		G 1"
Gas – Gas connection		G 3/4"
SiV – Safety valve		G 3/4"
KA – Condensate connection		Ø 25 mm

Gravity lock	blocked (valve opened)	Operating position
Paramount	Z  A	Z  A



For more information, see

Sealing and filling of the system, page 39

3.4 Dimensions and connections

Fig.3 Dimensions and Connections Paramount 50 - 115

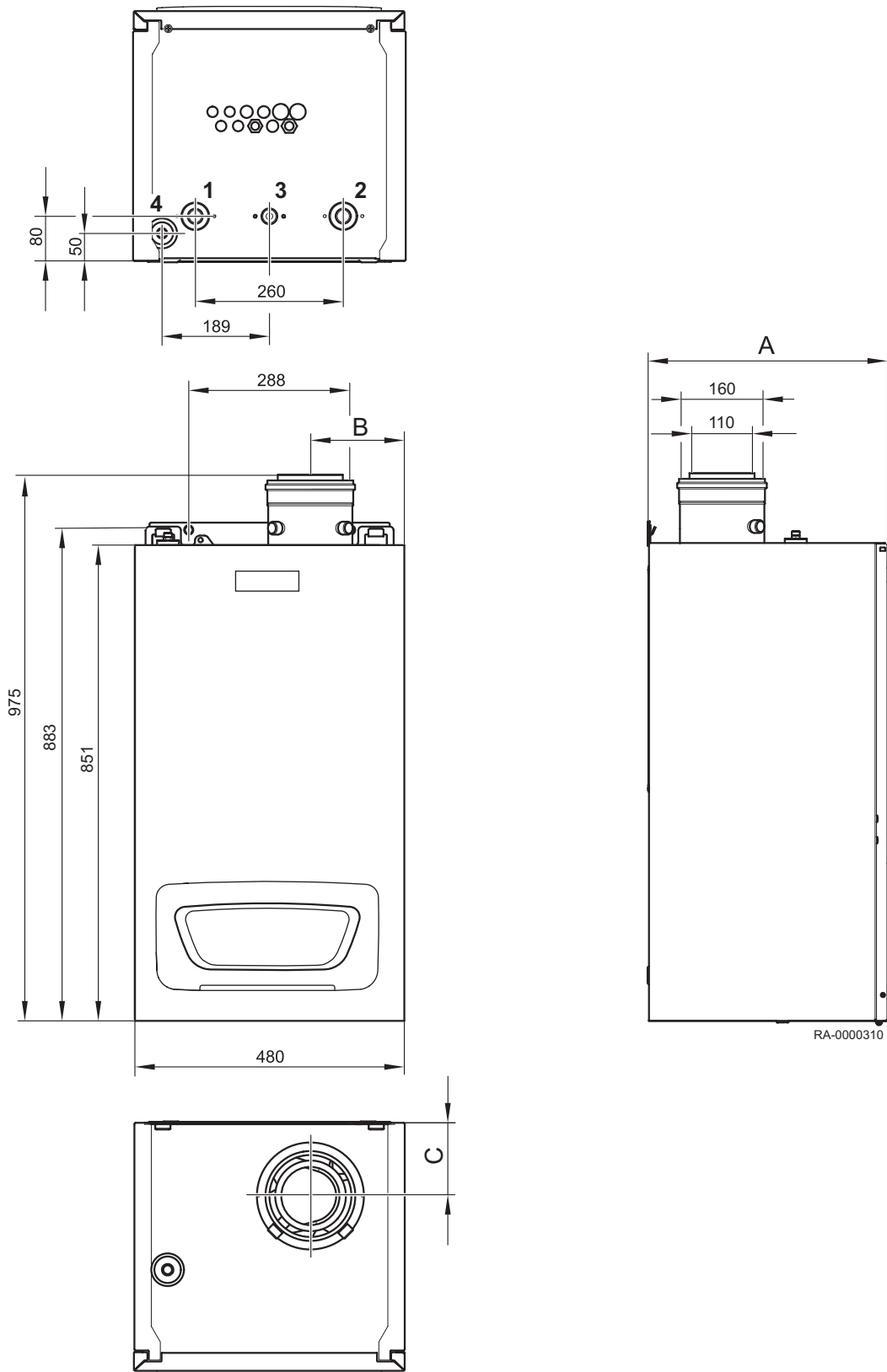

- 1 Heating flow
- 2 Heating return

- 3 Gas connection
- 4 Condensate connection

Tab.8 Dimensions and connections

Model		Paramount 50/60	Paramount 80	Paramount 95	Paramount 115
Heating flow		G 1 1/2"	G 1 1/2"	G 1 1/2"	G 1 1/2"
Heating return		G 1 1/2"	G 1 1/2"	G 1 1/2"	G 1 1/2"
Gas connection		G 1"	G 1"	G 1"	G 1"
Safety valve		G 3/4"	G 3/4"	G 3/4"	G 3/4"
Condensate connection		Ø 25 mm	Ø 25 mm	Ø 25 mm	Ø 25 mm
Dimension A	[mm]	447	542	580	580
Dimension B	[mm]	168	168	163	163
Dimension C	[mm]	132	132	152	152

3.5 Wiring diagram

Fig.4 Wiring diagram Paramount 30 / 40

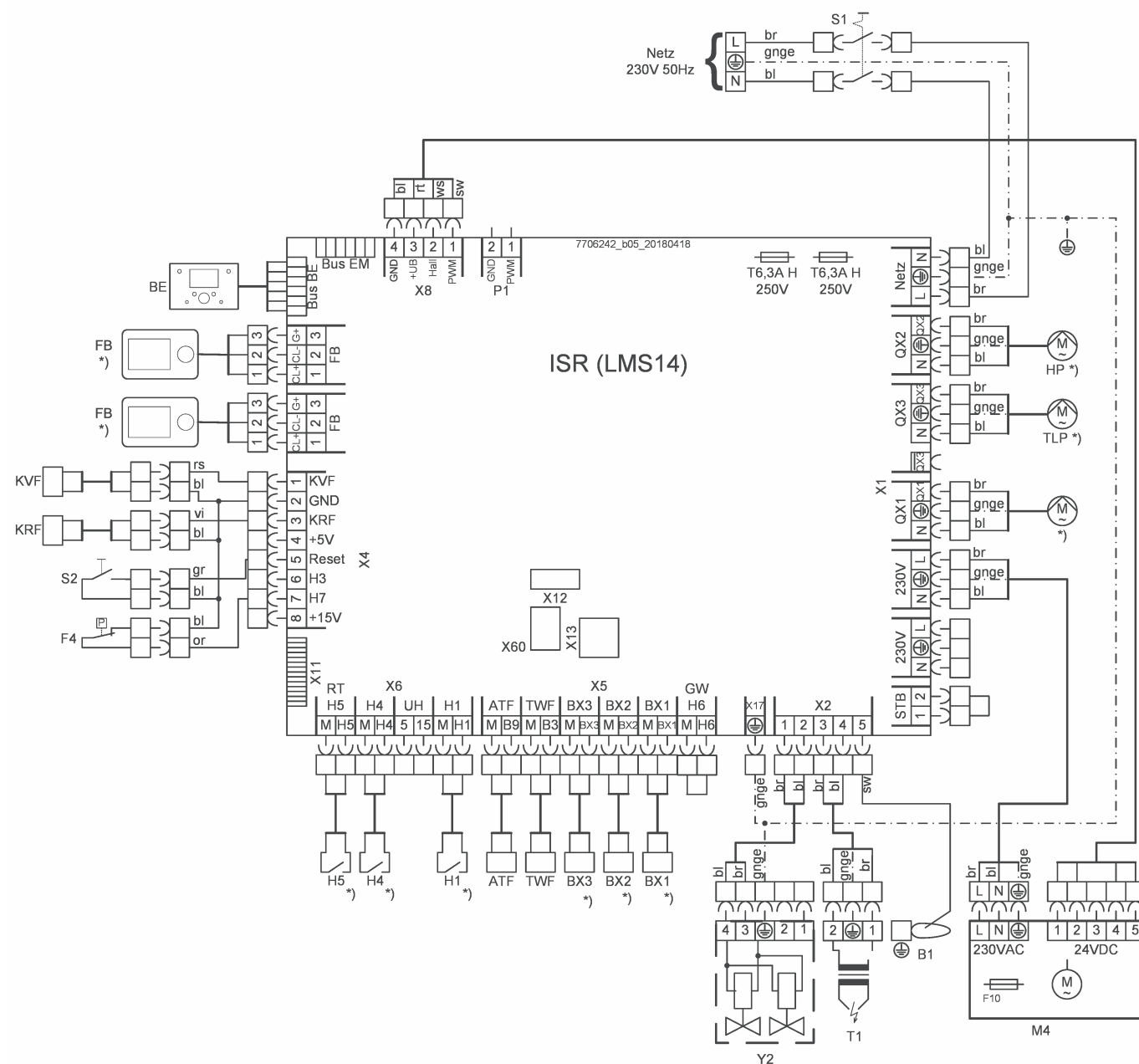

ATF Outdoor temperature sensor QAC 34
 B1 Ionisation electrode

BE Operating unit
 BusBE Bus connection for operating unit

- BusEM** Bus connection for expansion module
- BX1-3** Multi-function sensor input
- F4** Water pressure sensor
- FB** Remote control (accessory)
- GW** Gas pressure monitor
- H1,4,5** Multifunctional input (accessory)
- H6** Gas pressure monitor input
- HP** Heating circuit pump (accessory)
- KRF** Boiler return sensor type 36
- KVF** Boiler flow sensor type 36
- M4** Burner fan
- Netz** Mains connection

- P1** PWM output
- QX1-3** Multifunctional output
- S1** ON/OFF switch
- S2** Unlocking
- STB** Safety temperature limiter
- T1** Ignition transformer
- TLP** DHW charging pump (accessory)
- TWF** DHW sensor type 36
- X11,60** Bus module interface
- X12,13** Service interface
- Y2** Gas valve

Fig.5 Wiring diagram Paramount 50 / 60

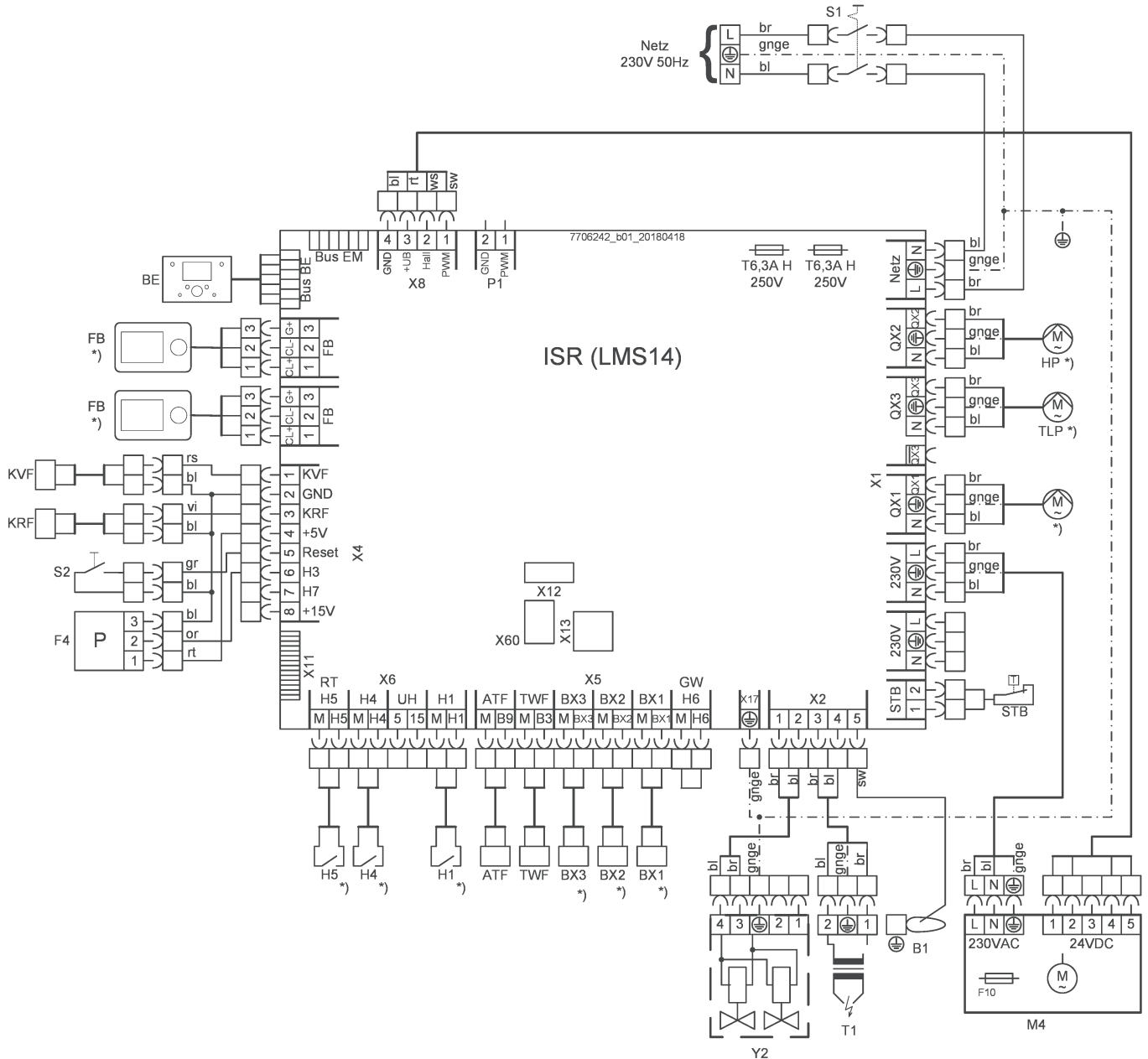

- ATF** Outdoor temperature sensor QAC 34
- B1** Ionisation electrode
- BE** Operating unit
- BusBE** Bus connection for operating unit
- BusEM** Bus connection for expansion module
- BX1-3** Multi-function sensor input
- F4** Water pressure sensor
- FB** Remote control (accessory)

- GW** Gas pressure monitor
- H1,4,5** Multifunctional input
- H6** Gas pressure monitor input
- HP** Heating circuit pump (accessory)
- KRF** Boiler return sensor type 36
- KVF** Boiler flow sensor type 36
- M4** Burner fan
- Netz** Mains connection

- P1** PWM output
- QX1-3** Multifunctional output
- S1** ON/OFF switch
- S2** Unlocking
- STB** Safety temperature limiter
- T1** Ignition transformer

- TLP** DHW charging pump (accessory)
- TWF** DHW sensor type 36
- X11,60** Bus module interface
- X12,13** Service interface
- Y2** Gas valve

Fig.6 Wiring diagram Paramount 80 - 115

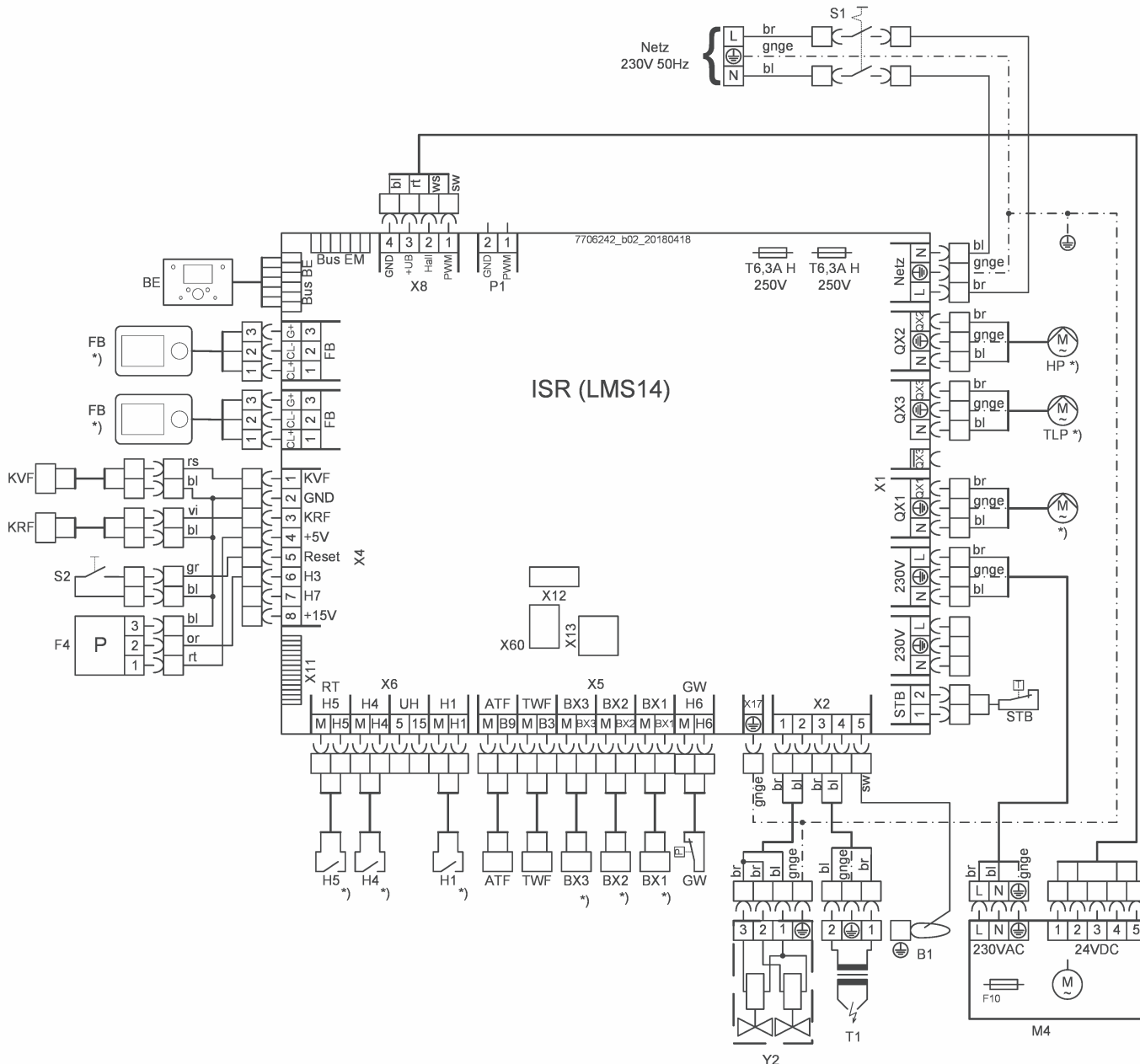

- ATF** Outdoor temperature sensor QAC 34
- B1** Ionisation electrode
- BE** Operating unit
- BusBE** Bus connection for operating unit
- BusEM** Bus connection for expansion module
- BX1-3** Multi-function sensor input
- F4** Water pressure sensor
- FB** Remote control (accessory)
- GW** Gas pressure monitor
- H1,4,5** Multifunctional input
- H6** Gas pressure monitor input
- HP** Heating circuit pump (accessory)
- KRF** Boiler return sensor type 36
- KVF** Boiler flow sensor type 36

- M4** Burner fan
- Netz** Mains connection
- P1** PWM output
- QX1-3** Multifunctional output
- S1** ON/OFF switch
- S2** Unlocking
- STB** Safety temperature limiter
- T1** Ignition transformer
- TLP** DHW charging pump (accessory)
- TWF** DHW sensor type 36
- X11,60** Bus module interface
- X12,13** Service interface
- Y2** Gas valve

4 Description of the product

4.1 Main components

Fig.7 Boiler view Paramount (depicted without front wall and regulator cover)
Paramount 30/40

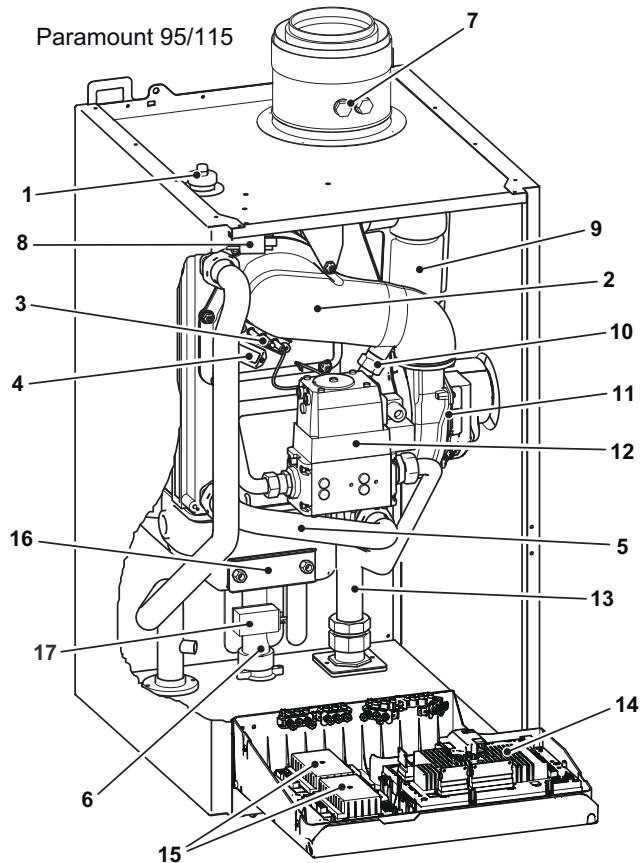
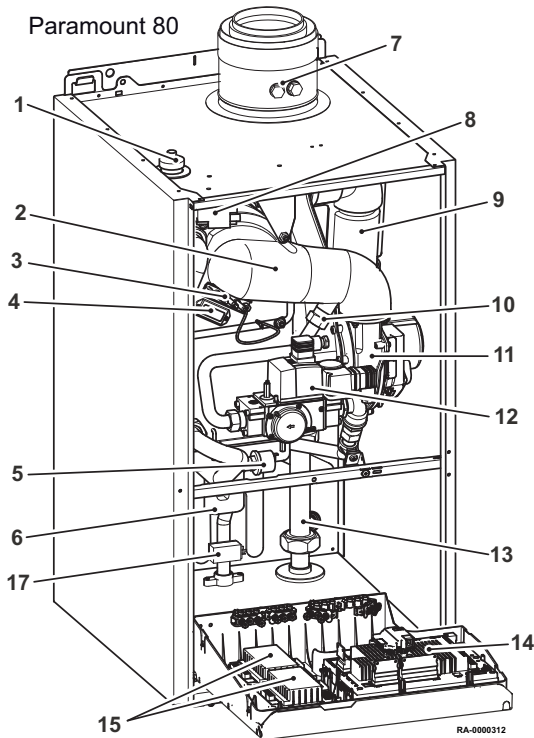
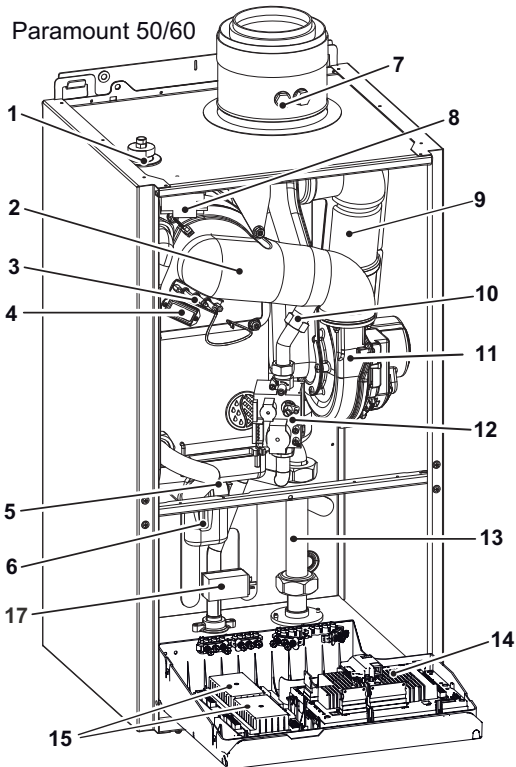
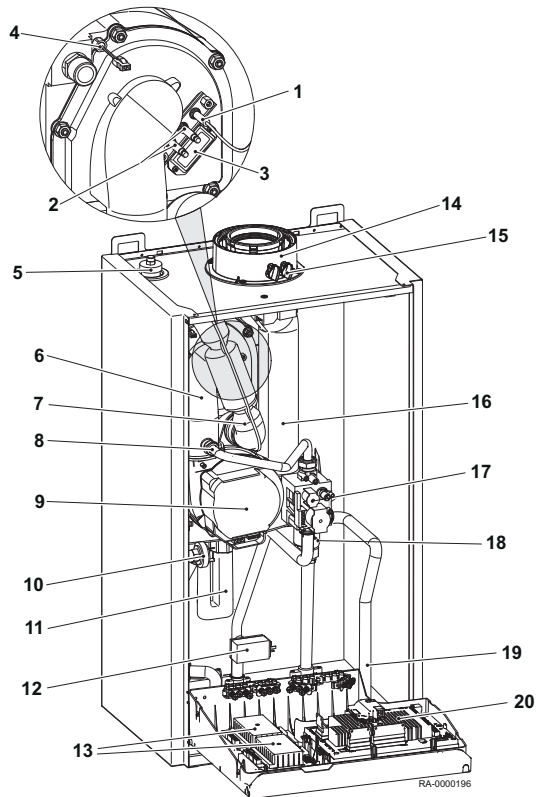

Paramount 30/40		Paramount 50 - 115	
1	Ionisation electrode	1	Air vent
2	Ignition electrodes	2	Mixing tube
3	Flame inspection window	3	Ignition and ionization electrode
4	Flow sensor	4	Flame inspection window
5	Air vent	5	Water pressure sensor
6	Mixing tube	6	Siphon
7	Air intake silencer	7	Flue gas adapter with inspection apertures
8	Gas injector	8	Ignition transformer (under the lid)
9	Fan	9	Air intake silencer
10	Water pressure sensor	10	Gas jet
11	Siphon	11	Fan
12	Gas pressure monitor	12	Gas valve
13	Extension module EWM ¹⁾	13	Pump replacement pipe ¹⁾
14	Flue gas adapter	14	Control LMS
15	Inspection openings	15	Extension module EWM ¹⁾
16	Flue gas pipe	16	Cleaning opening
17	Gas valve	17	Gas pressure monitor
18	Gravity lock		1) Accessories
19	Connection 2. heating circuit ¹⁾		
20	Control LMS		
	1) Accessories		

4.2 Control panel description

4.2.1 Operating elements

Fig.8 Operating elements

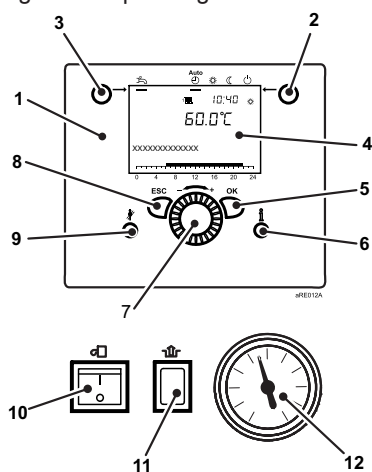

- 1 Regulator operating unit
- 2 Operating mode key, heating mode
- 3 Operating mode key domestic water mode
- 4 Screen
- 5 OK key (acknowledgement)
- 6 Information key
- 7 Control knob
- 8 ESC key (cancel)
- 9 Chimney sweep key
- 10 ON/OFF switch
- 11 Release key burner control
- 12 Pressure gauge

Fig.9 Symbols on the display

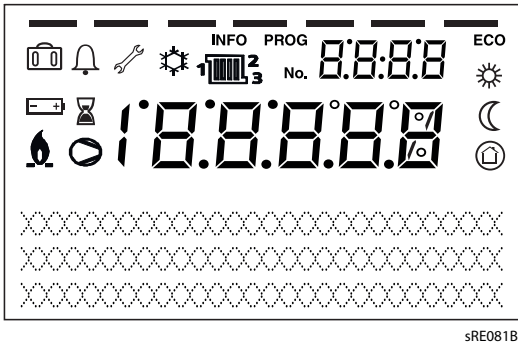

4.2.2 Displays

- Heating to comfort setpoint
- Heating to reduced setpoint
- Heating to frost protection setpoint
- Current process
- Holiday function active
- Reference to heating circuits
- Burner in operation (boiler only)
- Cooling active (heat pump only)
- Compressor in operation (heat pump only)
- Maintenance message
- Fault message
- INFO** Information level active
- PROG** Setting level active
- ECO** Heating system switched off (automatic summer/winter changeover or automatic heating limit active)

4.3 Standard delivery

- Gas condensing boiler for fitting to the wall, packed in a cardboard box
- Info package with manual
- Outside temperature sensor
- Mounting rail
- Accessories

4.4 Accessories & options

A list of the accessories (selection) available for the Paramount can be found below.

- Room device RGP
- Bus module BM
- Extension module EWM
- Shut-off set AEH
- Membrane expansion vessel MAG
- Connection pipe for mixing circuit MAR

4.4.1 Room device RGP

Remote setting of all adjustable control functions of the basic appliance is possible via the operating unit when using the room device RGP (accessory).

■ Operating elements

- 1 USB connection for service tool
- 2 Status bar
- 3 Work area
- 4 Control knob
- 5 Display
- 6 Navigation bar

The control knob is used to operate the room unit.

The display is organized into a navigation bar, status bar, and work area.

i Important
The current room temperature is displayed in standby.

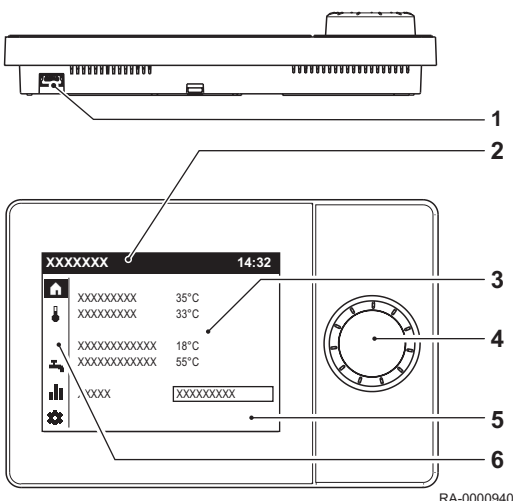

4.4.2 Installation of extension module

If an EWM extension module is installed, an application with one or two mixed heating circuits is possible.

5 Before installation

5.1 Regulations governing installation



Caution

Installation of the appliance must be done by a qualified engineer in accordance with prevailing local and national regulations.

5.2 Installation requirements

5.2.1 Corrosion protection



Caution

When connecting heat generators to under-floor heating systems employing plastic pipes which are not impervious to oxygen in accordance to DIN 4726, heat exchangers must be used for separation purposes.



Important

Prevention of damage in hot water heating systems caused by corrosion on the water side or scaling.

5.2.2 Supply air openings



Caution

Keep the inflow area clear.

Never block or close off ventilation apertures. The inflow area for combustion air must be kept clear.



Warning

Risk of damage!

The condensing boiler may only be installed in rooms with clean combustion air. Foreign matter such as pollen must never filter through the inlet apertures to reach the inside of the appliance. The boiler must not be started up if there is heavy dust development e.g. during construction work. There could be damage to the boiler.

For ventilation-based operation of the Paramount, an adequately sized opening for combustion air must be present in the place of installation. The operator must be informed that this opening must never be closed or blocked and that the connecting piece for combustion air on the upper side of the Paramount must be kept free at all times.

5.2.3 Treating and preparing the heating water

■ Introduction

This section explains the conditions for heating water when Potterton Commercial condensing boilers are used.



Important

Please note that the boiler Paramount has an **aluminium silicon heat exchanger**.

■ Protecting the heat generator

Faults in the heating circuit caused by corrosion or limescale deposits reduce the efficiency and functionality of the heat generator.

The quality of the fill water must meet specific requirements. You should therefore take preventive measures in certain cases.

- For systems with underfloor heating and piping which is permeable to oxygen, system separation must be used between the heat generator and other system parts which are at risk of corrosion.
- Heating systems in which a Potterton Commercial condensing boiler is to be installed must be designed as a closed heating system with diaphragm expansion vessel in accordance with DIN EN 12828.
- Directly connecting a Potterton Commercial heat generator to an "open" heating system is not permitted. System separation must also be used here. In "open" systems, the connection to the outdoor air causes oxygen to be absorbed in such a quantity that it leads to corrosion in the heating system. Furthermore, the objective of consistent energy savings is not achieved due to the additional heat loss via the "open" expansion vessel. Gravity systems with an "open" expansion vessel are not in line with current technology.

5.2.4 Heating water requirements



Caution

Note the requirement for the heating water quality.

Requirements regarding heating water quality have increased in recent times as system conditions have changed:

- Reduced heat demand.
- Use of cascades in larger buildings.
- Increased use of buffer cylinders in combination with solar thermal energy and solid fuel boilers.
- Power-generating heating systems.
- Storage tank charging systems and similar.

The focus is always on designing systems that are guaranteed to operate reliably throughout their service life without any faults.

The following requirements apply to the heating water quality in the entire circuit, based on VDI directive 2035 Sheets 1 and 2. In the case of renovation measures, it is not sufficient to merely fill partial sections according to VDI 2035.

- The pH of the heating water must be between 8.2 and 9.0 during operation. A corrosion inhibitor can be added to the heating water. The manufacturer specifications must be complied with.
- The water must not contain any foreign substances, such as beads of sweat, rust particles, scale, sludge or other sedimenting substances. During commissioning, flush the system until only clean water runs out. When flushing the system, ensure that water does not flow through the heat exchanger in the heat generator, that the radiator thermostats are removed and that the valve inserts are set to the maximum flow rate.

Generally speaking, the quality of drinking water is adequate, but a check must be performed to ensure that the drinking water available in the system is suitable for filling the system in terms of its hardness and water constituents (see *water hardness diagram*). If this is not the case, various measures are possible.

**Caution**

Warranty claims are excluded if the specified measures or required values are not adhered to or if documentation is missing.

■ Addition of a product to treat the heating water

**Caution**

Use only approved products or methods which have the following properties:

- **Hardness stabilisers** prevent the precipitation of hardness.
- **Cleaning products** dissolve dirt in the circuit and may also keep the dissolved dirt suspended.
- **Corrosion protection products** form a protective layer on metallic surfaces.
- **Full protection products** prevent the precipitation of hardness, have a cleaning effect, keep the dissolved dirt in suspension (dispersion) and form a corrosion protection layer on metallic surfaces.

Only products approved by Potterton Commercial may be used to treat heating water. Softening/desalination may only be carried out using appliances approved by Potterton Commercial, while taking the limit values into consideration.

**Caution**

If non-approved agents are used, no warranty rights or guarantees are valid.

The following products are currently approved by Potterton Commercial:

- "Full heating protection" from Fernox (www.fernox.com)
- „Sentinel X100“ from Sentinel (www.sentinelprotects.com)

If **products** are used, the manufacturer specifications must be observed. If it is necessary to use additives as part of a mixture in special cases, e.g. hardness stabiliser, antifreeze agent, sealant, etc., you must ensure that the agents are compatible with each other and that the required pH in the circuit continues to be adhered to. Preferably, agents from the same manufacturer should be used.

- Ensure that the electrical conductivity of the fill water corresponds to the manufacturer specifications for the relevant dosing rate, with the addition of an inhibitor.
- The electrical conductivity in the circuit must not rise significantly (+ 100 $\mu\text{S}/\text{cm}$), even after a prolonged running time, without the dose having been increased.
- The pH of the circuit water must be between 8.2 and 9.0 during operation.
- The pH, electrical conductivity and product content of the heating water must be checked after eight weeks of operation and then once per year.
- The measured values must be documented in the service book.

■ Softening/partial softening

Use of a softening system to treat the fill water and to prevent damage caused by the formation of scale in the boiler.

- Partially softened fill water according to the table from VDI 2035 Sheet 1 can generally be used.
- VDI 2035 Sheet 2 must be observed.
- The pH of the circuit water must be between 8.2 and 9.0 during operation.
- Automatic alkalisation of the system water (pH increase caused by carbon dioxide outgassing) begins under various conditions.
- The pH, electrical conductivity and °dH of the circuit water must be checked after eight weeks of operation and then once per year.
- Document the measured values in the service book.

**Important**

A softening system reduces calcium and magnesium to prevent the formation of scale (VDI directive 2035 Sheet 1). No corrosive water components are reduced or removed (VDI directive 2035 Sheet 2).

Tab.9 Table to VDI 2035 Sheet 1

Total heating output in kW	Total hardness in °dH depending on the specific system volume		
	< 20 l/kW	≤ 20 l/kW and < 50 l/kW	≥ 50 l/kW
< 50 ⁽¹⁾	≤ 16.8	≤ 11.2	< 0.11
50 - 200	≤ 11.2	≤ 8.4	< 0.11
200 - 600	≤ 8.4	< 0.11	< 0.11
> 600	< 0.11	< 0.11	< 0.11

(1) for circulation water heaters (< 0.3 l/kW) and systems with electric heating elements

■ Full desalination/partial desalination

Use of a desalination system to treat the fill water.

- Fully desalinated water or partially desalinated water can generally be used for filling.
- The electrical conductivity of desalinated additional water must not exceed 15 µS/cm for full desalination and 180 µS/cm for partial desalination.
- The electrical conductivity in the circuit must not exceed 50 µS/cm with full desalination and 370 µS/cm with partial desalination during filling.
- The pH of the circuit water must be between 8.2 and 9.0 during operation.
- The pH, electrical conductivity and product content of the heating water must be checked after eight weeks of operation and then once per year.
- Desalination of fill and top-up water to obtain fully desalinated water should not be mistaken for softening down to 0 °dH. Water softening does not remove corrosive salts.

■ Maintenance



Caution

The quality of the circuit water must be checked and documented as part of annual system maintenance. Depending on the measurement result, the necessary measures must be taken in order to re-establish the required values for the circuit water. Furthermore, the cause of the changes must be established and permanently corrected in the event of severe deviations. Warranty claims are excluded if the specified values are not adhered to or if documentation is missing.

5.2.5 Determining the system volume

Fig.10 Determining the system volume

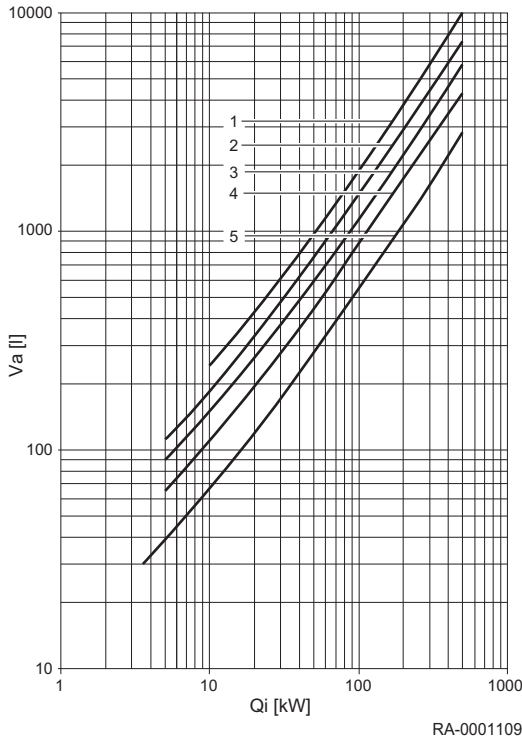

- Q_i Rated system output
- V_a Average total water content
- 1 Underfloor heating
- 2 Steel radiators
- 3 Cast iron radiators
- 4 Steel panel radiators
- 5 Convectors

The total water volume in the heating system is calculated using the system volume (= fill water volume) plus the top-up water volume. In the Potterton Commercial boiler-specific diagrams only the system volume is given to make them easier to read. Over the entire service life of the boiler, a maximum top-up volume of twice the system volume is assumed.

5.2.6 Practical information for qualified heating specialists

- If an appliance is replaced in an existing system, we recommend installing a sludge separator, e.g. WAM C SMART (accessory) in the system return, upstream of the heat generator. Potterton Commercial recommends using the AguaClean filtration module to achieve an optimum cleaning result, including magnetite deposits.
- Document the filling (VDI directive 2035 Sheet 2 Section 4 "Principles"). The **Potterton Commercial service book** must be used for this.
- To prevent gas pockets and gas bubbles, it is essential to fully vent the heat generator at maximum operating temperature.
- Offer maintenance contracts for all the equipment in the system.
- Check proper operation with regard to pressure maintenance on an annual basis.
- Potterton Commercial recommends using of approved systems for initial filling, for replacing water and for top-ups.

5.2.7 Use of antifreeze agents with Potterton Commercial heat generators



Important

The use of antifreeze agents with Potterton Commercial gas-fired condensing boilers with aluminium heat exchangers.

The heat transfer fluid WTF B (accessory) offered for solar thermal systems is also used in heating systems (e.g. holiday homes) as an antifreeze agent. The freezing point ("crystallization point") of the ready mixed heat transfer fluid is -24 °C and the maximum frost protection ("setting point") is -32 °C. As it has a lower heat capacity than pure water but is more viscous, boiling noises may occur under unfavourable system conditions.

Frost protection down to -32 °C is not required for most heating systems; -15 °C is usually sufficient. The heat transfer fluid must be diluted 2:1 with water to set this operating point. This mixing ratio has been tested by Potterton Commercial in relation to its practical suitability for use with condensing boilers.



Important

Up to a mixing ratio of 2:1, the heat transfer fluid WTF B is approved as frost protection down to -15 °C for use with Potterton Commercial condensing boilers.



Caution

Keep the installation room frost-free.

If an antifreeze agent is used, pipework, radiators and condensing boilers are protected against frost damage. For the condensing boiler to be ready for operation at any time, suitable measures must also be taken to keep the installation room frost-free. If applicable, please also note special measures for any installed domestic hot water calorifiers.

The table shows the relevant volumes of heat transfer fluid and water that need to be mixed together for varying volumes of water. If other frost protection temperatures are required in exceptional cases, individual calculations can be made on the basis of this table.

Water content of the system [l]	Volume WTF B [l]	Mixing in water ⁽¹⁾ [l]	Frost protection down to [°C]
50	36	14	-15
100	71	29	-15
150	107	43	-15
200	143	57	-15
250	178	72	-15
300	214	86	-15
500	357	143	-15
1000	714	286	-15

(1) The water for the mixture must be neutral (drinking water quality with no more than 100 mg/kg chlorine) or demineralised. Please also follow the manufacturer instructions.

5.3 Choice of the location

5.3.1 Requirements for the installation room

**Notice**

The installation room must be dry and frost-free.

**Caution**

Do not stock chloride or fluoride compounds close to the boiler. They are particularly corrosive and may contaminate the combustion air. Chloride and fluoride compounds are present in aerosol sprays, paints, solvents, cleaning products, washing products, detergents, glues, snow clearing salts.

**Warning****Risk of damage!**

The condensing boiler may only be installed in rooms with clean combustion air. Foreign matter such as pollen must never filter through the inlet apertures to reach the inside of the appliance. The boiler must not be started up if there is heavy dust development e.g. during construction work. There could be damage to the boiler.

**Danger**

Changes to conducts for combustion air and flue gas are only allowed after consultation with the district chimney sweep responsible. Such changes include:

- Making the set-up location smaller
- Retrofitting joint-sealed windows and outside doors
- Sealing windows and outside doors
- Covering or removing supply air apertures
- Covering chimneys

**Caution****Keep the inflow area clear.**

Never block or close off ventilation apertures. The inflow area for combustion air must be kept clear.

**Important**

There are inspection apertures for the chimney sweep in the flue gas spigot on top of the boiler.

- Ensure that these inspection apertures are always accessible.

5.3.2 Notes for installation location



Danger

Danger caused by the boiler falling!

The boiler may fall as a result of unsuitable rawl plugs and a wall that does not have sufficient load-bearing capacity.

- Use suitable rawl plugs to secure the boiler.
- The wall must have sufficient load-bearing capacity and be able to bear the weight of the boiler.
- The enclosed rawl plugs are suitable for use in a full brick wall.



Caution

Danger of damage from water!

The following must be observed when installing the Paramount: In order to prevent damage due to water, particularly due to leakages in the DHW storage tank, suitable precautionary measures should be taken regarding installation.

Installation room

- The installation room must be dry and frost-free.
- The installation location has to be selected particularly with respect to the routing of the flue gas pipes. When installing the boiler, the specified wall clearances have to be maintained.
- Along with the general rules of the technology, especially the regulations of the federal German states, such as fire and construction ordinances as well as heating room guidelines, must be observed. There should be sufficient space in front of the equipment to carry out inspection and maintenance work.



Caution

Danger of damaging the device!

Aggressive foreign substances in the combustion supply air can destroy or damage the heat generator. Therefore the installation in rooms with heavy dust accumulation is only allowed with room air independent operating modes.

If the Paramount is operated in rooms in which solvents, cleaning agents containing chlorine, paints, glues or similar substances are worked with or in which such substances are stored, only room air independent operation is permissible. This applies especially for rooms in which ammonia and its compounds, nitrites and sulphides are present (animal breeding and recycling facilities, battery and galvanising rooms, etc.).

During the installation of the Paramount under these conditions DIN 50929 (Corrosion probability of metallic materials with external corrosion loading) as well as information sheet i. 158; "German Copper Institute" is heeded.

For damages occurring due to the installation in an unsuitable location or based on improper combustion air supply, there is no warranty claim.

5.3.3 Operation in bath and shower rooms

Fig.11 Clearances in bath and shower rooms

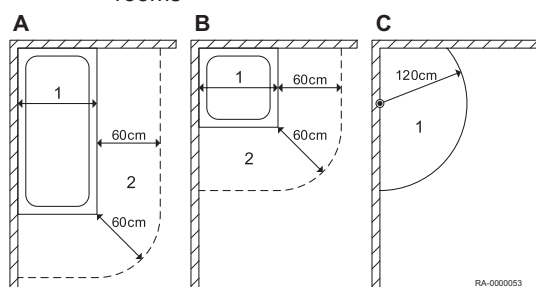

1 Protection area 1 (above bathtub)

2 Protection area 2

A Bath without fixed partition

B Shower tray without fixed partition

C Shower with fixed shower head and no fixed partition



Important

For showers without a tray, the dimension 120 cm is measured horizontally from the fixed shower head or from the attached water outlet; there is no area 2.

On delivery, the Paramount complies with protection type IPx4D during room-sealed operation, and it must be installed in protection area 2 (see figure). In protection area 1, the Paramount only has to be installed if the maximum water volume at the shower head is less than 10 litres per minute.



Danger of electric shock

For an installation in protection area 1 or 2, a residual current device (RCD) with a rated differential current that is no greater than 30 mA must be provided.

Potterton Commercial does not accept any warranty claims for corrosion damage caused by a permanent heavy splash load.

To comply with protection type IPx4D, the following conditions must be met:

- Room air-independent operation
- All outgoing or incoming electrical lines must be installed through tension release screw fittings and fixed.



Caution

The screw fittings have to be tightened, so that no water can enter the inside of the housing!

Operating a room device or thermostat in protection areas 0–2 is not permitted!

5.4 Transport

5.4.1 General



Danger

Some components, e.g. the preinstalled components or certain spare parts, exceed the recommended maximum lifting capacity for individual people that is recommended by employment law. Risk of personal injury caused by heavy loads.

- Do not work alone.
- Use the lifting aids.
- Secure the unit during transport.
- Do not place any other objects on the unit.



Danger

Risk of injury due to the unit tipping over!

- When using transport aids, ensure that the weight is distributed evenly.



Caution

Risk of damage to the unit caused by impact during transport.

- The unit must be protected against heavy impacts during transport.



Notice

You must ensure that any stairs and doors have sufficient passage width before transporting the unit.



Caution

During transport, only lift the unit onto load-bearing panels or the parts provided for this purpose for transport.



Notice

Always transport the boiler as close to the installation site as possible before the packaging is removed.

5.5 Unpacking

**Caution****Sharp-edged packaging material**

Risk of cuts on the sharp-edged cardboard packaging

- Wear gloves when unpacking the unit.

**Danger****Risk of asphyxiation!**

The unit's packaging material (e.g. plastic film) presents a risk of asphyxiation for children.

- Never allow children to play with packaging material.

**Important**

Dispose of packaging material correctly.

6 Installation

6.1 General



Warning
Risk of injury!

Objects (e.g. tools) that are carelessly placed on the unit lead to a risk of injuries and damage.

- Do not place any objects on the unit. Even for a short time!

6.2 Hydraulic connections

Fig.12 Installation of disconnecter valves

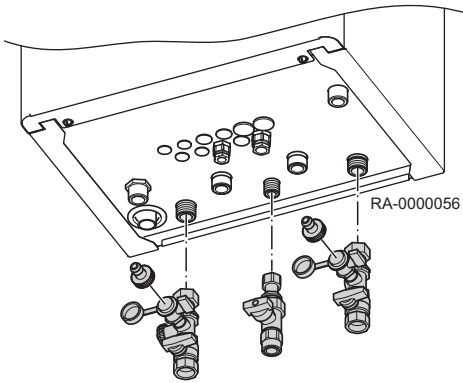

6.2.1 Connecting the heating circuit

Connect the heating circuit with flat seal screw connections to boiler flow and boiler return.

Disconnecter valves have to be installed into the flow and return. To facilitate the assembly, the shut-off set ADH (accessory) may be used.

Disconnecter valves have to be installed into the flow and return. To facilitate the assembly, the shut-off set ADH or AEH (accessory) may be used.



Important
Installing filter.

Installation of a filter is recommended in the heating return. In the case of old plants, the whole heating plant should be thoroughly flushed before installation.

6.2.2 Safety valve

Mount the membrane expansion vessel with the heating systems closed.



Caution
The connecting pipe between boiler and safety valve must not be blockable.

The installation of pumps and fittings or pipe reducer pieces is not permissible. The blow-off line of the safety valve must be designed in such a way that the pressure does not increase when the safety valve responds. It must not be routed to the outside, the opening must be clear and observable. Any heating water that may possibly escape should be safely drained off.



Caution
The blow-off line of the safety valve must be designed in such a way that the pressure does not increase when the safety valve responds. It must not be routed to the outside, the opening must be clear and observable. Any heating water that may possibly escape should be safely drained off.

6.2.3 Connecting the expansion vessel

1. Ensure that an expansion vessel with a sufficient fill quantity and correct inlet pressure is present.
2. Install the expansion vessel on the disconnecter valve (ADH/AEH accessory) for the flow pipe from the Paramount boiler.

6.2.4 Condensate

A direct run-off of the condensate into the domestic drainage system is only allowed if the system only comprises corrosion-resistant materials (e.g. PP-pipe, stoneware or similar materials).

The condensate must be able to flow freely into a funnel. A stench trap must be installed between the funnel and drainage system.

The condensate hose of the Paramount must be inserted through the opening in the floor.

If there is no run-off facility underneath the condensate discharge, the use of a Potterton Commercial neutralisation and lifting system is recommended.



Caution
Danger of damaging the device!

The condensate hose must be laid with even gradient to the funnel (at least 3 cm/m). Avoid horizontal pipe routing. The hose must not exhibit any siphon-like bends (double siphon). Fill the condensate discharge in the Paramount with water before commissioning. For this, fill 0.25 l water in the flue outlet before assembly of the flue gas pipe.

6.2.5 Sealing and filling of the system

1. Fill the heating system via the return flow of the Paramount (see note below)!
2. Check tightness (see note below for max. operating pressure).



For more information, see
Technical data, page 15
Dimensions and connections, page 18

6.3 Gas connection

6.3.1 Gas connection

The gas-side connection may only be carried out by an approved installer. For the gas-side installation and setting, the factory setting data of the equipment and optional label should be compared with the local supply conditions.

An approved thermally activated disconnecter valve must be installed upstream of the Paramount.

If old gas pipes still exist in the region, the installation of a gas filter is recommended.

Residues in pipes and pipe joints should be removed.

6.3.2 Venting the gas line

The gas line must be vented before initial commissioning.

For this, open the measuring nozzle for the connecting pressure and vent, taking the safety precautions into account. Check for tightness of the connection after venting.

**Danger
Danger to life by gas!**

- The entire gas pipe, particularly the joints must be checked for leakages before commissioning.

6.4 Air supply/flue gas outlet connections

6.4.1 System certification

The system certification complies with Gas Appliances Directive 2016/426/EC, the rules of the DVGW VP 113 (German Technical and Scientific Association for Gas and Water) and standard 15502-1. The joint approval for the Potterton Commercial flue gas piping system with a Potterton Commercial gas-fired condensing boiler is documented by the corresponding CE product identification number. The CE number is specified in the table of technical data (see reference).

No additional CE approval for the flue gas piping system is required.



For more information, see
Technical data, page 15

■ Identifying the system certification

The Potterton Commercial flue gas piping system must be labelled following the installation. Each basic kit for the Potterton Commercial flue gas piping systems includes a sticker for the CE certification. The installed flue gas piping system must be marked with a check on the sticker and this must be attached close to the gas-fired condensing boiler.

6.4.2 Flue gas connection

For the operation of the Paramount as a gas condensing boiler, the flue gas pipe should be designed with the flue gas temperature under 120°C (flue gas pipe type B).



Important
The enclosed assembly instructions for the flue gas system have to be observed.

Fig.13 Connection possibilities with KAS (accessory)

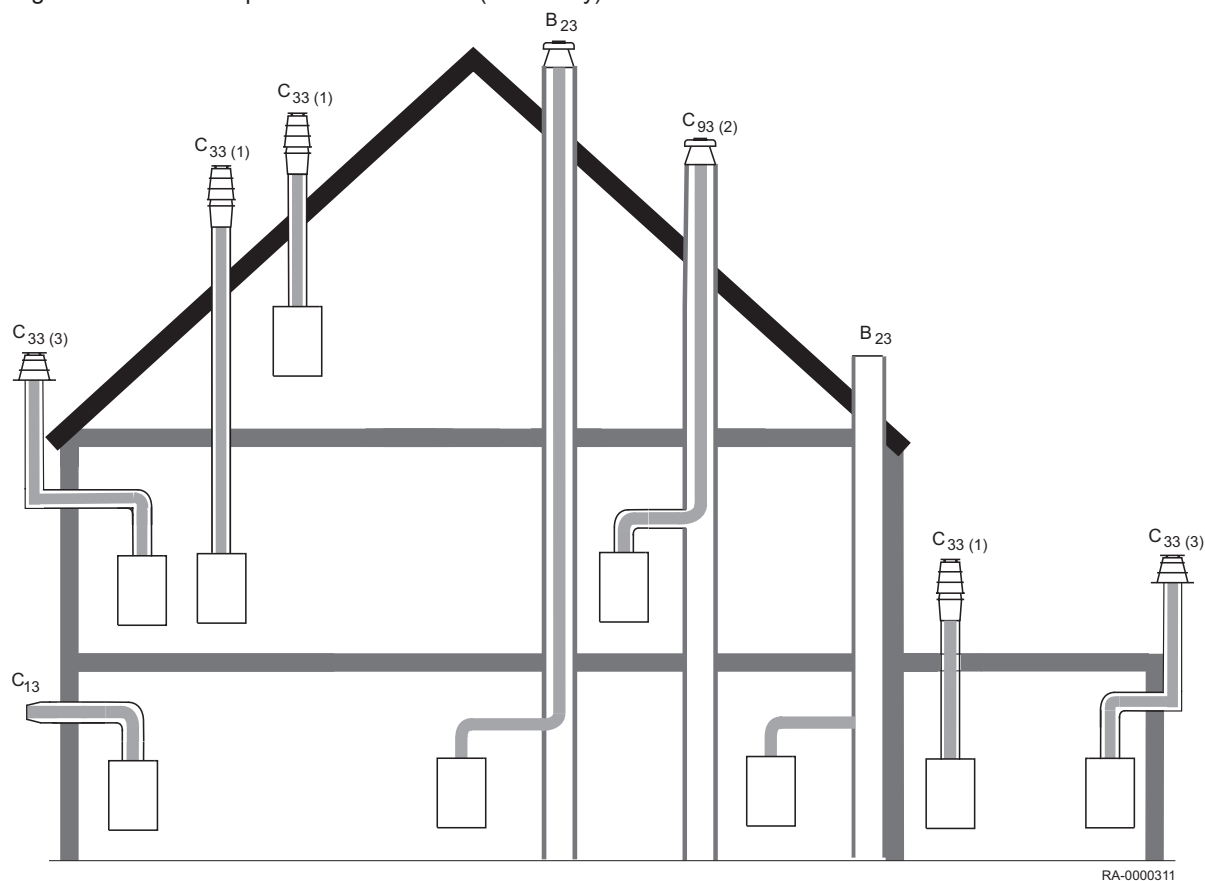

RA-0000311

6.4.3 Permissible flue gas pipe lengths

Paramount	28 / 38			50 / 60			70			90			110		
	Flue Size	Max Flue Length ⁽¹⁾	Max. No of Bends (90°)	Flue Size	Max Flue Length ⁽¹⁾	Max. No of Bends (90°)	Flue Size	Max Flue Length ⁽¹⁾	Max. No of Bends (90°)	Flue Size	Max Flue Length ⁽¹⁾	Max. No of Bends (90°)	Flue Size	Max Flue Length ⁽¹⁾	Max. No of Bends (90°)
C13 (Concentric Vertical)	80/125	10(5)	2	110/150	5(5)	2	110/150	5(5)	2	110/160	5(5)	2	110/160	5(5)	2
C33(1) (Concentric Vertical)	80/125	13	0	110/180	22	0	110/180	13	0	110/180	10(3)	0	110/180	10(3)	0
C33(1) (Concentric Vertical)	110/160 ⁽²⁾	20	0				120/180 ⁽²⁾	20	0				120/180 ⁽²⁾		
C93(2) (Concentric Vertical)	80/125	15(3)	2	110/180	24(3)	2	110/180	15(3)	2	110/180	18(3)	2	110/180	20(3)	2
C33(3) (Concentric Vertical)	80/125	7(3)	2	110/180	13(2)	2	110/180	9(3)	2	110/180			110/180		
B23 (Conventional Flue) ⁽²⁾	80	20(3)	3	110	25(3)	3	110	16(3)	3	110	20(3)	2	110	20(3)	2

(1) This is the maximum flue length, the allowable horizontal run within total flue length is shown in brackets.
(2) not supplied by Potterton Commercial



See

Flue sizes shown for the Concentric Vertical Flue are adapted sizes for flues supplied by Potterton Commercial. For flues supplied by other manufacturers, please refer to technical data for standard spigot sizes.

**See**

BS 5440 states a suitable guard should be provided whenever the appliance terminal is fitted less than 2 m above ground, above a balcony or flat roof.

**For more information, see**

Power compensation for increasing the permissible flue gas piping lengths, page 42

6.4.4 Power compensation for increasing the permissible flue gas piping lengths

The maximum flue gas piping lengths arise from the requirement that the power reduction by the flue gas counter-pressure is no more than 5%. For systems in which the "Max. total length of the flue gas piping" that is specified in the "Permissible flue gas piping lengths" table (see reference below) is not sufficient, the boiler's fan speed can be increased. This means that the power reduction is compensated for and larger flue gas piping lengths can be used (see table "Permissible flue gas piping lengths", "Max. total length of the flue gas pipe following power compensation").

Prog. no. 9626 and 9627 must be changed for this power compensation. You are in the "Burner control" menu. The changed values for operating with natural gas or LPG can be found in the tables below.

Tab.10 Speed parameters for power compensation, **natural gas**

Setting	Prog. no.	Designation	Paramount 50	Paramount 80	Paramount 95	Paramount 115
Factory setting	9626	Fan output/speed slope	111.3	78.3	63.1	58.6
	9627	Fan output/speed Y-section	140	120	320	260
Setting for power compensation	9626	Fan output/speed slope	118.3	83.5	67.2	—
	9627	Fan output/speed Y-section	70	30	240	—

Tab.11 Speed parameters for power compensation, **LPG**

Setting	Prog. no.	Designation	Paramount 50	Paramount 80	Paramount 95	Paramount 115
Factory setting in accordance with the conversion set	9626	Fan output/speed slope	111.8	74.5	58.7	54.9
	9627	Fan output/speed Y-section	8	186	327	157
Setting for power compensation	9626	Fan output/speed slope	119.2	79.8	63.1	
	9627	Fan output/speed Y-section	-80	74	195	

**For more information, see**

Permissible flue gas pipe lengths, page 41

6.4.5 General information about the exhaust gas piping system

Standards and regulations

Besides the general technical rules, the following should be particularly observed:

- Regulations of the accompanying certificate of approval
- Planning laws and building regulation.

■ Contaminated chimneys

Combustion of solid and liquid fuels generates deposits and pollution in the respective flue gas tract. Soot contaminated with sulphur and halogenated hydrocarbons sticks to the inside walls. Such flue gas tracts are not suitable for the combustion air supply of heat generators without pretreatment. Contaminated combustion air is one of the main causes of

corrosion damage and malfunctions on fuel-burning installations. If the combustion air has to be drawn via an already existing chimney, this flue gas tract should be inspected and if necessary cleaned. Should structural deficiencies (e.g. old, broken chimney structures) oppose its use as a combustion air supply duct, suitable measures such as shake-out of the fireplace should be taken. It must be ensured that there is no contamination of the combustion air with foreign matter.

If an appropriate clean up of the existing flue gas tract is not possible, the heat generator can be operated on a concentric flue gas pipe independent of ventilation. . The concentric flue gas pipe must run straight in the shaft.

■ Lightning protection



Danger of electric shock Danger to life due to lightning strike.

The chimney head cover must be integrated in any existing lightning protection system and house-side potential equalisation. This work should be carried out by an approved company specializing in lightning protection and electrical work.

■ Shaft requirements

Inside buildings, exhaust gas system should be laid in suitable ventilated shafts. The shafts must be made of non-combustible, dimensionally stable materials.

Fire resistance duration of the shaft: 90 min.

Fire resistance duration of the shaft in case of buildings of lower building height: 30 min.

6.4.6 Mounting the flue gas system



Warning Danger of injury by not wearing working gloves.

Wearing working gloves is recommended during assembly work, particularly while cutting the pipes.

Mounting with gradient

The flue pipe must be routed at a gradient to the Paramount so that the condensation from the flue pipe can drain from the flue pipe to the central condensation collector of the Paramount.

The min. gradients are:

- horizontal flue pipe: min. 3° (min. 5.5 cm per metre)
- external wall duct: min. 1° (min. 2.0 cm per metre)

Shortening of the pipes

All simple and concentric pipes may be shortened. After cutting, the ends of the pipes have to be thoroughly de-burred. When a concentric pipe is shortened, a piece of pipe at least 6 cm long must be cut off the outer pipe. The spring washer for centring the inner pipe becomes obsolete.

1. The pipes and formed pieces have to be fitted together up to the connector basis. Only the original profile seals of the building kit or the original spare seals may be used between the individual elements. Before assembly, the seals must be treated with the silicone paste which is part of the scope of delivery. When routing the pipes care must be taken that the pipes are installed in line and without tension. In this way leaking of the seals is prevented.

Fig.14

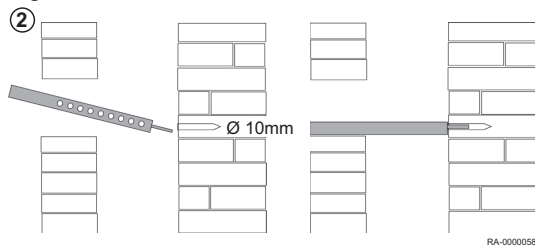

2. For fastening the support rail in the opposite wall of the shaft opening, a bore hole ($\varnothing=10$ mm) must be provided on the level fo the opening edge. Then the pin of the support rail has to be hammered into the bore hole.

Fig.15

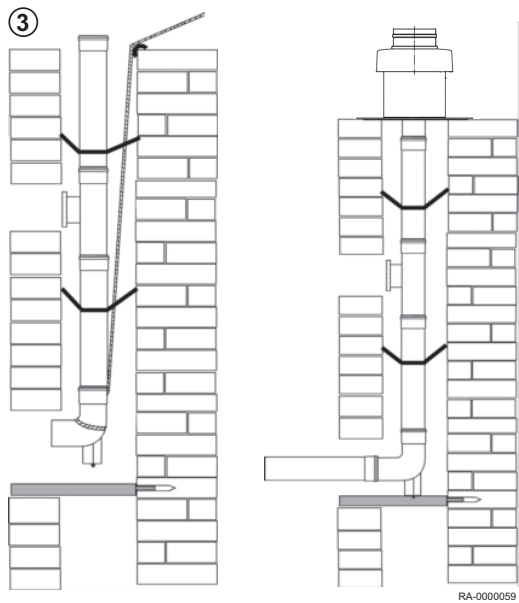

3. The flue pipe is lowered from the top into the shaft. For this, connect a rope to the support leg and insert the pipes, section by section, from the top. To prevent the components sliding apart during assembly, the rope must be kept on tension until the final assembly of the flue pipe. If spacers are necessary, these have to be fitted to the duct at least every 2 m.
4. Cant the spacers at a right angle and align centric in the shaft. Pipes and formed parts are to be installed in such a way that the connectors are arranged counter to the flow direction of the condensed water.

After the pipes have been inserted, place the support leg in the support rail and align (flush and without tension). The shaft cover at the chimney head must be assembled in such a way that no rainfall can get into the space between flue pipe and shaft and the air for back ventilation can flow freely.

**Caution**

When the flue pipes are dis-assembled, new seals must be used for the reassembly!

6.4.7 Outlets

**Important**

When codes of practice dictate the use of a terminal guard use a suitable guard of stainless steel construction. There must be a clearance of at least 50 mm between any part of the terminal and the guard.

Fig.16 Outlets

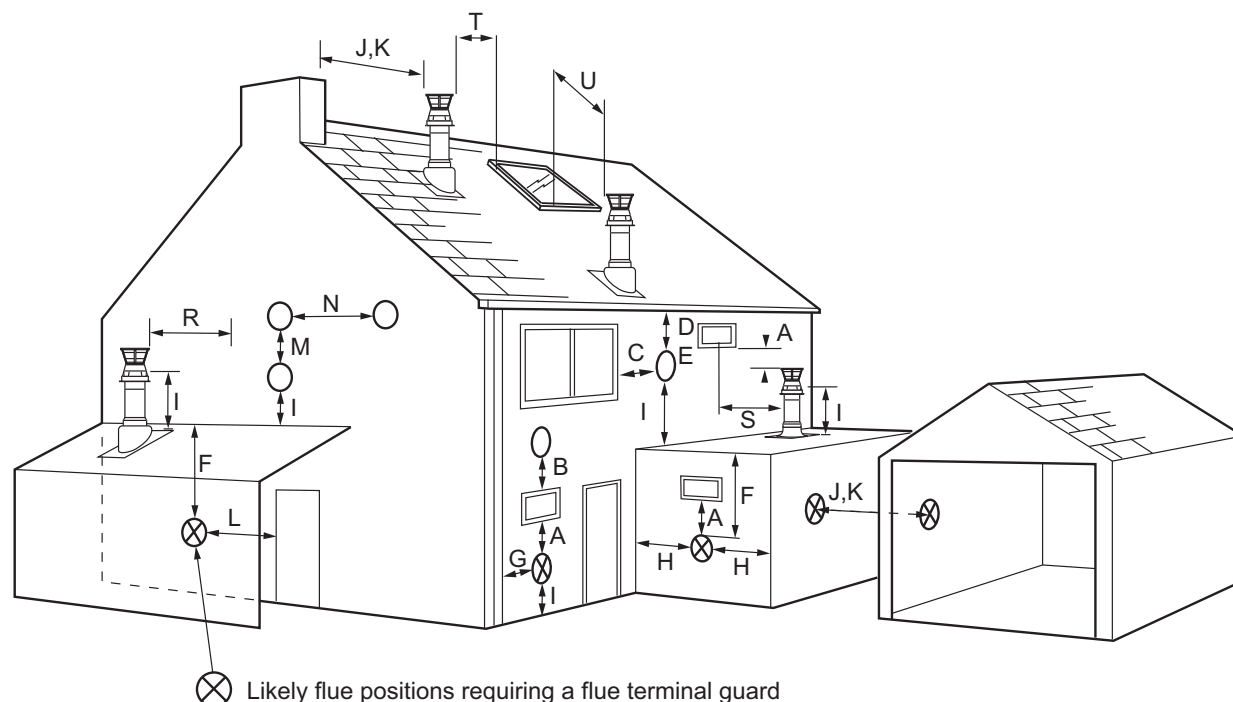

AD-3000707-01

Tab.12 Terminal position with minimum distance

A ⁽¹⁾	Directly below an opening, air brick, opening windows, etc.	300 mm
B ⁽¹⁾	Above an opening, air brick, opening window etc.	300 mm
C ⁽¹⁾	Horizontally to an opening, air brick, opening window etc.	300 mm
D ⁽²⁾	Below gutters, soil pipes or drain pipes.	25 (75) mm
E ⁽²⁾	Below eaves.	25 (200) mm
F ⁽²⁾	Below balconies or car port roof.	25 (200) mm
G ⁽²⁾	From a vertical drain pipe or soil pipe.	25 (150) mm
H ⁽²⁾	From an internal or external corner.	25 (300) mm
I	Above ground, roof or balcony level.	300 mm
J	From a surface or boundary line facing a terminal.	600 mm
K	From a terminal facing a terminal (Horizontal flue). From a terminal facing a terminal (Vertical flue).	1200 mm 600 mm
L	From an opening in carport (e.g. door, window) into the dwelling.	1200 mm
M	Vertically from a terminal on the same wall.	1500 mm
N	Horizontally from a terminal on the same wall.	300 mm
R	From adjacent wall to flue (vertical only).	300 mm
S	From an adjacent opening window (vertical only).	1000 mm

T	Adjacent to windows or openings on pitched and flat roofs.	600 mm
U	Below windows or openings on pitched roofs.	2000 mm
<p>(1) In addition, the terminal should be no nearer than 150 mm to an opening in the building fabric formed for the purpose of accommodating a built-in element such as a window frame.</p> <p>(2) Only one 25 mm clearance is allowed per installation. If one of the dimensions D, E, F, G or H is 25 mm then the remainder MUST be as shown in brackets, in accordance with BS 5440-1</p>		

6.4.8 Chimneys already in use

If a chimney used before for oil or solid fuel-fired boilers is used as a shaft for installation of a concentric exhaust gas pipeline, the chimney must be thoroughly cleaned first by a specialist.



Important

The concentric flue gas pipe must run straight in the duct.

- Height above the roof

- With regard to the minimum height above the roof, country-specific regulations regarding chimneys and flue gas systems are applicable.

6.4.9 Cleaning and inspection openings



Danger

Clean exhaust gas pipelines!

It should be possible to clean the flue gas pipes and inspect their free cross-section and leakproofness.

At least one cleaning and inspection opening must be installed in the installation room of the Paramount.

Exhaust gas pipes in buildings, which cannot be cleaned or inspected from their port side must have an additional cleaning port in the upper part of the exhaust system or above the roof.

The exhaust gas pipelines at the outer wall must have at least one cleaning opening in the lower part of the exhaust gas facility. For exhaust gas facilities with building heights of < 15.00 m in the vertical section, a pipeline length of < 2,00 m in the horizontal section and a maximum pipeline diameter of 150 mm with a maximum deflection (except for deflection directly at the boiler and in the shaft) one cleaning and inspection opening in the installation room of the Paramount is sufficient.

The ducts for exhaust gas facilities must not have any openings other than the necessary cleaning and inspection ports as well as openings for back ventilation of the exhaust gas pipe.

6.5 Electrical connections

6.5.1 Electrical connection (general)



Danger of electric shock

Danger to life through incorrect work!

All electrical work in connection with the installation may only be carried out by a trained electrician.

- Mains supply AC 230 V +6% -10%, 50 Hz

In Germany the VDE 0100 and local regulations must be followed during installation; in all other countries, follow the relevant regulations.

The electrical connection should be made with correct and non-reversible polarity. In Germany the connection can be executed as an accessible plug and socket connection with non-reversible polarity or as a fixed connection. In all other countries, a fixed connection must be provided.

For the power supply, use the power cable attached to the boiler or cable types H05VV-F 3 x 1 mm² or 3 x 1.5 mm². The earthing cable must be longer at the connection in order to guarantee that this connection is the last cable to rupture in the event of a hazard.

We recommend the installation of a mains isolator upstream of the Paramount. This should isolate all poles and provide contact separation of at least 3 mm.

i Important

For boilers with a total rated output of more than 100 kW, a switch (emergency switch) must be fitted in front of the boiler outside the room where the boiler is installed. This switch should be identified by a sign featuring the text "EMERGENCY SWITCH FOR BOILER".

All connected components must be executed compliant with VDE regulations. Always apply strain relief to connecting cables.

Cable types



Danger of electric shock

Danger to life! Risk of injury or a risk to life from electric shock!

The use of rigid lines (e.g. NYM) is not allowed because of the risk of cable damages! There are only to use flexible cables, e.g. H05VV-F for high voltage power cables, and e.g. LIYY for sensor cables.

6.5.2 Cable lengths

Bus/sensor lines do not have mains voltage, but safety extra-low voltage. They must **not be routed in parallel to the mains cables** (interference signals). Otherwise shielded cables must be installed.

Pipe length permitted:

- Cu-cable up to 20 m: 0.8 mm²
- Cu-cable up to 80 m: 1 mm²
- Cu-cable up to 120m: 1.5 mm²

Cable types : e.g. LIYY or LiYCY 2 x 0.8

6.5.3 Strain reliefs

All the cables should be fixed in the strain relief clamp of the control panel and connected according to the connection diagram.



For more information, see
Wiring diagram, page 21

Fig.17 Strain reliefs

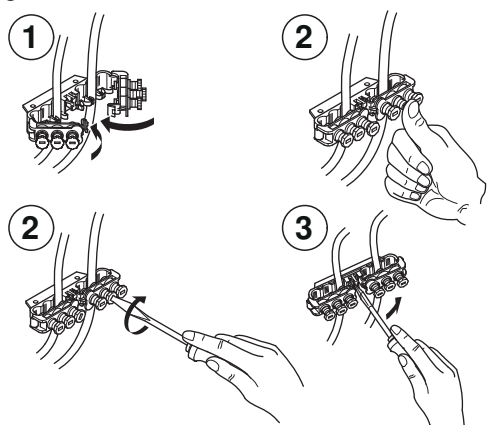

RA-000064

6.5.4 Replacing cables

All connecting cables, except for the mains connection cable, have to be replaced by Potterton Commercial special cables in case of replacement. When replacing the mains connection cable, only cables of the types H05VV-F 3 x 1 mm² or 3 x 1,5 mm² have to be used.

6.5.5 Protection against contact

**Danger of electric shock****Danger to life due by missing shock-proof protection.**

To ensure shock-proof protection, all parts of the boiler to be screwed on – the casing parts in particular – must be screwed on correctly after work has been completed.

6.5.6 IP rating IPx4D

Tighten the cable entries to comply with the IPx4D rating and to safeguard the specified air-tight sealing of the air chamber, so that the grommets tighten around the cables.

6.5.7 Circulating pumps

The permissible current load per pump output is $I_{N \max} = 1A$.

6.5.8 Appliance fuses

Appliance fuse in the control unit ISR:

- Mains fuses: T 6.3A H 250V

6.5.9 Connecting sensors/components

**Danger****Risk of electric shock! Danger to life through incorrect work!**

The wiring diagram must be followed! Optional accessories must be fitted and connected according to the instructions provided. Connect to the mains. Check earthing.

Outdoor temperature sensor (included in delivery)

The outdoor temperature sensor is located in the accessory bag. It should be connected according to the wiring diagram.

7 Commissioning

7.1 General



Danger

Commissioning may only be carried out by an approved installer. The installer checks the tightness of pipes, the correct function of all regulating, control and safety equipment, and measures the combustion values. If this work is not carried out correctly, there is a risk of considerable damage to persons, environment and property.

7.2 Checklist for commissioning

Tab.13 Checklist for commissioning

1.	System location			
2.	Customer			
3.	Boiler type/Designation			
4.	Serial number			
5.	Characteristic gas values	Wobbe index	kWh/m ³	
6.		Operating heating value	kWh/m ³	
7.	Have all pipelines and connections been checked for tightness?			<input type="checkbox"/>
8.	Flue gas system checked?			<input type="checkbox"/>
9.	Gas pipeline checked and vented?			<input type="checkbox"/>
10.	Static pressure measured at the gas valve inlet?		mbar	
11.	Free wheeling of pumps checked?			<input type="checkbox"/>
12.	Filling the heating plant			<input type="checkbox"/>
13.	Water additives used			
14.	Gas flow pressure measured at full load at the gas valve inlet?		mbar	
15.	Gas injector pressure measured at full load at the gas valve outlet?		mbar	
16.	CO ₂ content at low load		%	
17.	CO content at low load		ppm	
18.	CO ₂ content at full load		%	
19.	CO content at full load		ppm	
20.	Function test:	Heating mode		<input type="checkbox"/>
21.		Domestic water mode		<input type="checkbox"/>
22.	Programming:	Time /date		<input type="checkbox"/>
23.		Comfort setpoint heating circuit 1/2	°C	
24.		Setpoint DHW	°C	
25.		Automatic day time programme	Clock	
26.		Heating curve checked?		<input type="checkbox"/>
27.	Tightness of the flue system checked in operation (e.g. CO ₂ test in annular gap)?			
28.	Customer instructed?			<input type="checkbox"/>
29.	Documents handed over?			<input type="checkbox"/>
Only components tested and marked according to the respective standard have been used. All system components have been installed according to the instruction of the manufacturers. The whole system conforms to the standard. To ensure the heat source operates reliably and economically for a long period, we recommend annual maintenance for the heat generator.				Date /signature Company stamp

7.3 Commissioning procedure

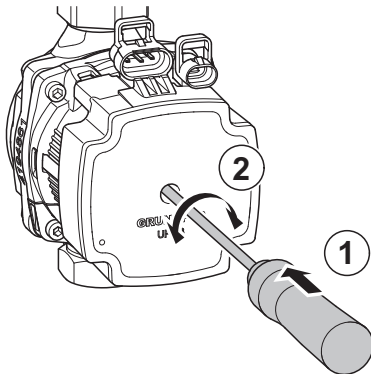

RA-0000994

7.3.1 Checking that the pump is running normally

If required, the pump (type UPM3) can be checked to ensure that it is running normally.

1. Insert a screwdriver into the front hole in the pump.
2. By turning and applying pressure at the same time, you can establish that the pump is running normally.

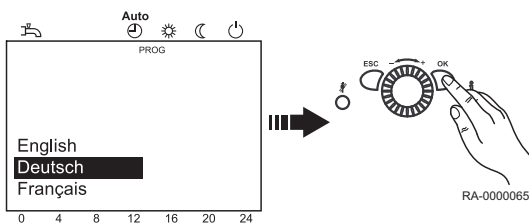

RA-0000065

7.3.2 Commissioning menu

The commissioning menu will be shown once during initial commissioning.

1. Select Language and confirm with **OK-Taste**.
2. Select Year and confirm.
3. Set Time of day and date and confirm.
4. Conclude by pressing the **OK-Taste**.



Important

If the commissioning menu entry is terminated by pressing **ESC-Taste**, the menu will be shown again next time the appliance is switched on.

7.4 Gas settings

7.4.1 Factory settings

The Paramount has been set to the nominal heat load by the manufacturer.

- Gas type G20 (natural gas G20 with Wobbe index $W_{oN} = 15.0 \text{ kWh/m}^3$)

The specific set gas type can be seen on the optional label glued to the burner. The factory setting data must be checked against the on-site supply conditions before installation of the Paramount.

7.4.2 Supply pressure

The supply pressure must be between the values given in the technical data table (see reference below).

The connecting pressure is measured as pressure in the gas flow at the measuring nozzle of the gas valve.



Danger

The Paramount must not be started up when the supply pressures are outside the said range.
The gas supply company must be informed.



For more information, see

Technical data, page 15
Gas valve, page 52

7.4.3 CO₂ content

The CO₂ content in the exhaust gas must be checked during commissioning and during regular maintenance of the boiler, as well as after reconstruction work on the boiler or on the exhaust gas system.

CO₂ content during operation see section *Technical data*.



Caution

Risk of damage to the burner!

Too *high* CO₂ values can lead to unhygienic combustion (high CO values) and damage to the burner.

Too *low* CO₂ values can lead to ignition problems.

The CO₂ value is set by adjusting the gas pressure at the gas valve. If the Paramount is used in areas with fluctuating natural gas composition, the CO₂ content must be adjusted in accordance with the Wobbe index at any given time (ask the gas supply company).

The CO₂ content to be set can be decided as follows:

- CO₂ content = 8.5 - (W_{oN} - W_{oCurrent}) * 0,5
- until Paramount 50: CO₂ content = 8,5 - (W_{oN} - W_{oCurrent}) * 0,5
- above Paramount 50: CO₂ content = 8.8 - (W_{oN} - W_{oCurrent}) * 0.5

The air quantity set in the factory must not be changed.



For more information, see

Technical data, page 15

7.4.4 Changing over from natural gas to LPG and vice versa



Danger

Danger! Danger to life by gas!

The gas type of the Paramount may only be changed by an approved heating specialist. The Potterton Commercial conversion kit for LPG (accessory) must be used. The instructions of the conversion kit must be observed!

The CO₂ content is set by adjusting the injection nozzle pressure on the gas valve.

The CO₂-content must be between the values according to section *Technical Data* at full load as well as low load.



For more information, see

Technical data, page 15

7.4.5 Gas valve

Fig.18 Gas valve

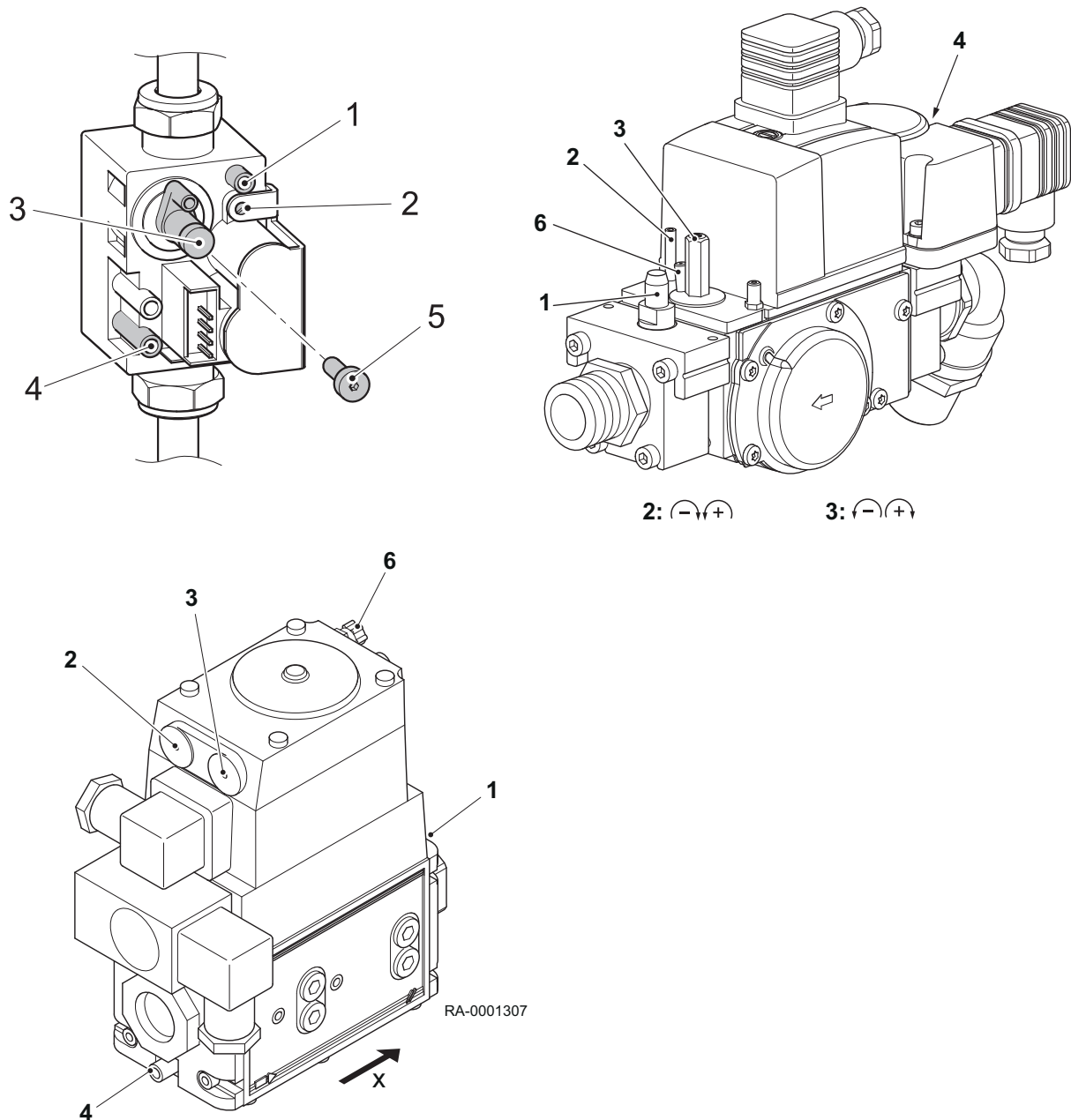

- 1 Measuring nozzle for injector pressure
- 2 Setting for full load
- 3 Setting for low load (remove protective plug in advance (5))
- 4 Measuring nozzle for connecting pressure
- 5 Protective plug
- 6 Fan pressure
- x Flow direction

Setting of jet pressures:

- Paramount 30 - 60: Torx T15
- Paramount 80: Allen key 2,0 mm
- Paramount 95 - 115: Allen key 2,5 mm

i Important

The Torx-key is located in the accessory bag.

7.4.6 Manual adjustment of burner output (controller stop function)

For controlling the CO₂ values the Paramount operated in the **control stop function**

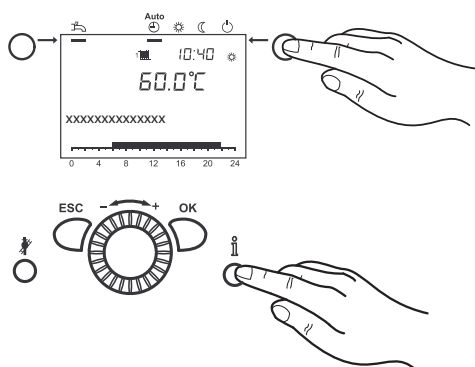

1. Press button **Operating mode button heating operation** for approx 3 s
⇒ The message Controller stop active is displayed.
2. Wait until the display has reached the basic display again.
3. Press the Info button
⇒ The message Controller stop setpoint appears on the display. The actual modulation degree will be displayed on the display.
4. Press **OK**.
⇒ The setpoint can now be changed.
5. Press **OK**.
⇒ The setpoint displayed is then adopted by the controller.



Important

The regulator stop function is stopped by pressing the **operating mode button Heating Operation** for approximately 3 seconds, reaching the maximum boiler temperature or a time limit. If there is demand for heat from a coiled tubing storage tank, this demand will continue to be met during the controller stop function.

7.4.7 Guidance values for gas flow rate, injector pressure and CO₂ content

The values given in are for guidance. It is important that the gas quantity is set via the injector pressure in such a way that the CO₂ value is within the specified values.

If the Paramount is used in areas with fluctuating natural gas composition, the CO₂ content must be adjusted in accordance with the Wobbe index at any given time (ask the gas supply company).

The CO₂ content to be set can be decided as follows:

- to Paramount 60: CO₂ content = 8,5 - (W_{oN} - W_{ocurrent}) * 0,5
- over Paramount 60: CO₂ content = 8.8 - (W_{oN} - W_{ocurrent}) * 0,5

7.4.8 Guidance values for the gas flow rate

Tab.14 Guide values for the gas flow rate for natural gas

Model		Paramount 30	Paramount 40
Nominal input (full load)	kW	30	38
Gas flow rate		l/min	l/min
	7	71	90
	7.5	67	84
	8	63	79
Operating heating value	8.5	59	74
H _{uB} in kWh/m ³	9	56	70
	9.5	53	67
	10	50	63
	10.5	48	60
	11	45	58
	11.5	43	55

7.4.9 Guidance values for the gas flow rate

Tab.15 Guide values for the gas flow rate for natural gas

Model		Paramount 50	Paramount 60	Paramount 80	Paramount 95	Paramount 115
Nominal input (full load)	kW	50,0	58.0	77.0	95.0	115.0
Gas flow rate		l/min	l/min	l/min	l/min	l/min
	7	119	138	183	226	274
	7.5	111	129	171	211	256
	8,0	104	121	160	198	240
Operating heating value	8.5	98	114	151	186	225
H _{UB} in kWh/m ³	9,0	93	107	143	176	213
	9.5	88	102	135	167	202
	10	83	97	128	158	192
	10.5	79	92	122	151	183
	11	76	88	117	144	174
	11.5	72	84	112	138	167

7.4.10 Guidance values for injector pressure

Tab.16 Guidance values for injector pressure (full load)

Model			Paramount 30	Paramount 40
Injector diameter for				
Natural gas E (G20)		mm	4,90	7,80
LPG (propane)		mm	3,90	5,80
Guide values for injector pressure ⁽¹⁾				
G20 (15,0) ⁽²⁾		mbar	8,3 - 9,3	6.0 - 7.0
Propane		mbar	8,3 - 9,3	6.0 - 7.0
CO ₂ -content: see reference below				
(1) At pressure at end of boiler 0 mbar, 1013 hPa, 15 °C				
(2) Values in brackets = Wobbe Index W _{ON} in kWh/m ³				



For more information, see
Technical data, page 15

7.4.11 Guidance values for injector pressure

Tab.17 Guidance values for injector pressure (full load)

Model		Paramount 50	Paramount 60	Paramount 80	Paramount 95	Paramount 115
Injector diameter for						
Natural gas E (G20)	mm	7,00	7.80	9.00	8.50	10.30
LPG (propane)	mm	5,80	6,20	7,20	6.50	7,40
		Guide values for injector pressure ⁽¹⁾				
G20 (15,0) ⁽²⁾	mbar	7,2 - 7,7	6,5 - 7,5	8.0 - 9.0	13,0 - 14,0	13,0 - 14,0
Propane	mbar	7,1 - 7,6	7,0 - 8,0	8,1 - 9,1	15,0 - 16,0	15,0 - 16,0
CO ₂ -content: see reference below						
(1) At pressure at end of boiler 0 mbar, 1013 hPa, 15 °C						
(2) Values in brackets = Wobbe Index W _{ON} in kWh/m ³						



For more information, see
Technical data, page 15

8 Operation

8.1 Changing parameters

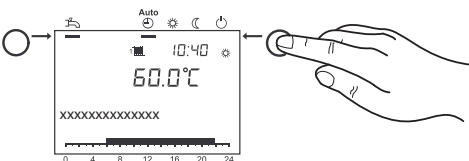
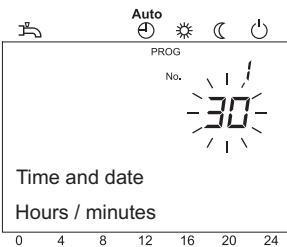
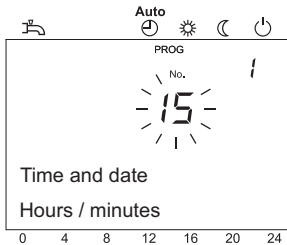
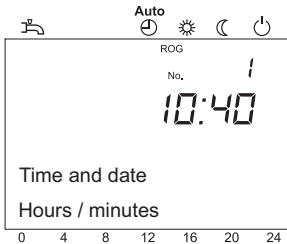
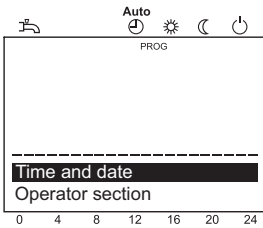
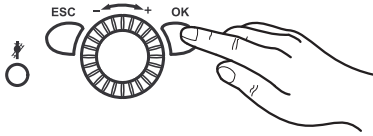

Settings which are not directly changed via the operating panel must be carried out on the setting level.

The basic programming process is depicted in the following using the example of the setting of Time of day and date.

1. Press **OK**.
⇒ The menu items under the *End user* level are displayed.



Important

If parameters are to be changed on a level other than the end user level, please see the note below!

2. Use the control knob to select the menu item Time of day and date.
3. Press **OK**.

4. Use the control knob to select the menu item Hours / minutes.
5. Press **OK**.

6. Carry out hour setting (e.g. 15 h) using the control knob.
7. Press **OK**.

8. Carry out minute setting (e.g. 30 minutes) with the control knob.
9. Press **OK**.

10. Leave the programming level by pressing the **operating mode key for heating mode**.



Important

The previous menu item is retrieved by pressing the **ESC key** without applying previously modified values. If no settings are carried out for approximately 8 minutes, the basic display is called up without applying previously modified values.



For more information, see

Programming procedure, page 57

8.2 Programming procedure

The selection of the setting levels and menu items is done as follows:

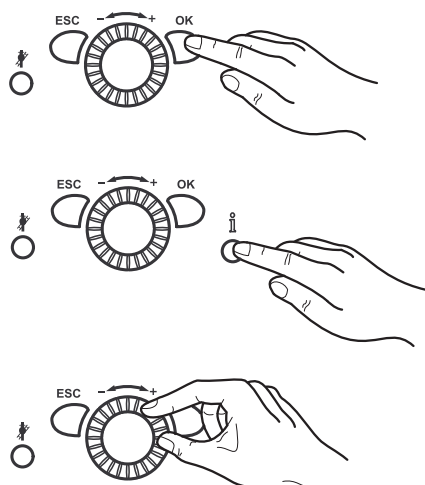

1. Press **OK**.
⇒ The menu items under the *End user* level are displayed.
2. Press **information button** for approx. 3 s.
⇒ The setting levels appear.
3. Select the required setting level using the control knob.

Setting levels
- End user (Eu)
- Commissioning (C), incl. end user (Eu)
- Engineer (E), incl. end user (Eu) and commissioning (C)
- OEM, includes all other setting levels (password-protected)

4. Press **OK**.
5. Select the required menu item (see parameter list) using the control knob.



See

Not all menu items will be visible, depending on the selection of the programming level and the programming.



For more information, see

List of parameters, page 62

8.3 Checking water pressure

- Less than 1.0 bar: Top up water.



Caution

Observe the maximum permissible system pressure.

- Over 6.0 bar: Do not put the gas condensing boiler into operation. Drain the water.



Caution

Observe the maximum permissible system pressure.

- Check that there is a drip pan below the discharge pipe from the safety valve. In the case of overpressure, it collects heating water as it is expelled.

8.4 Checking the domestic water storage tank

Where systems work with a domestic water storage tank, this must always be filled with water. In addition, it must be possible for cold water to enter.

8.5 Preparing start-up

This section describes which general work has to be done to switch the boiler on.

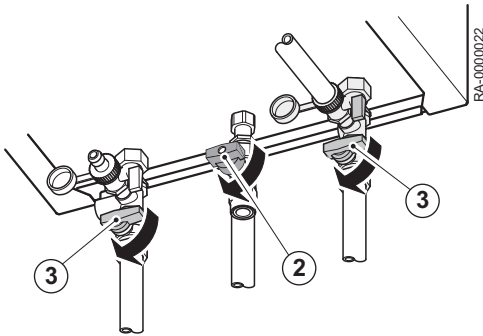
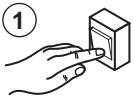

1. Switch on the heating emergency switch.
2. Open the gas tap.
3. Open the disconnecter valves.
4. Open the domestic water supply.
5. Open the front panel cover and switch the ON/OFF switch on the front panel of the boiler to on.

The Paramount can be put into operation without further settings being necessary. For information regarding setting e.g. an individual time program, please see the *Operation* chapter.



For more information, see
Changing parameters, page 56

8.6 Setting the heating mode

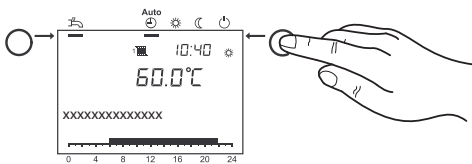

The **operating mode key for heating mode** enables a changeover between the various heating operating modes. The selected setting is marked with a bar underneath the operating mode symbol.

Automatic mode

- Heating mode according to time program
- Temperature setpoints or according to time program
- Protection functions (plant frost protection, overheating protection) activated
- Automatic summer/winter changeover (automatic switching over between heating and summer operation from a certain outside temperature onwards)
- Automatic day heating limit (automatic changeover between heating and summer operation, if outside temperature exceeds the room setpoint value)

Continuous mode or

- Heating mode without time program
- Protection functions activated
- Automatic summer/winter changeover is not activated
- Automatic day heating limit is not activated

Protection mode

- No heating operation
- Temperature according to frost protection setpoint
- Protection functions activated
- Automatic summer/winter changeover active
- Automatic day heating limit active

8.7 Adjusting domestic water mode

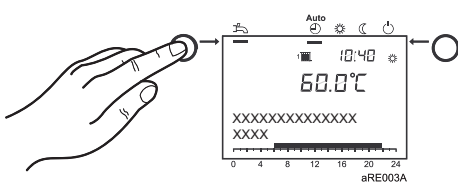

- Switched on Domestic water is prepared according to the selected switching programme.
- Switched off Domestic water preparation has been de-activated.

i Important

- A setting between 50 and 60°C is recommended for domestic water heating.
- Times for domestic water heating are set in time program 4 / DHW.

For reasons of convenience, domestic water heating should start approx. 1 h before central heating commences.

i Important Legionella function

Each Sunday during the first charge of the DHW tank, the legionella function is activated; this means the DHW is being heated up to 65 °C once for eliminating the existing legionellas.

8.8 Adjusting comfortable room setpoint

How to adjust the comfortable room setpoint is described here.

1. Set the comfort setpoint using the control knob.
⇒ => The value is taken over automatically.

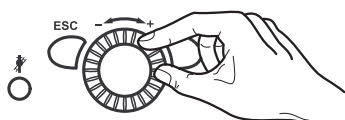
**8.9 Setting reduced room setpoint**

How to set the reduced room setpoint is described here.

1. Press **OK**.
2. Select the Heating circuit menu item.
3. Press **OK**.
4. Select the Reduced setpoint parameter.
5. Press **OK**.
6. Set the reduced setpoint at the control knob.
7. Press **OK**.
8. Leave the programming level by pressing the **operating mode key for heating mode**.

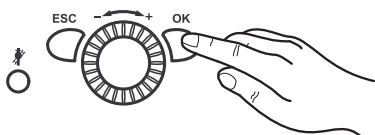
**8.10 Pump setting (pumped heating circuit)**

A hydraulic design calculation of the system is required for the correct setting of the pump modulation.

The pump inside the boiler is actuated by parameter 2320 (Pump modulation) with the modulation setting "Demand". This means that it modulates between the set minimum and maximum pump speed depending on the heating demand. The pump strives to use the least energy possible to supply the heating circuit.

Fig.19 Example of total dynamic head

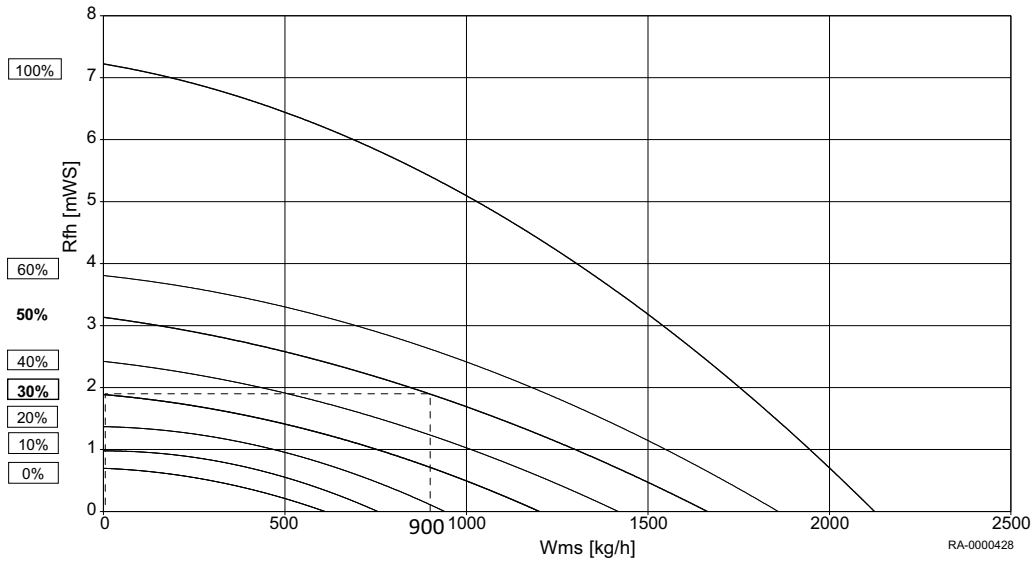

Rfh Total dynamic head

Wms Water mass flow

1. Parameter 883 (Pump speed max)
The max. pump speed results from the design volume flow and the total dynamic head required at this point (see Fig.).

⇒

Tab.18 Example (Fig.)

Design volume flow	900 l/h
System resistance at the design point	19 kPa (1.9 mWS)
⇒ Max. speed (read off)	50%
⇒ Set parameter 883	50%

2. Parameter 882 (Pump speed min)
 - 2.1. Heating systems with radiators
The minimum pump speed for heating systems with radiators is the result of entering the system resistance again at volume flow zero l/h in the diagram (see Fig.).

⇒

Tab.19 Example (Fig.)

System resistance at the design point	19 kPa (1.9 mWS)
⇒ Min. speed (read off)	30%
⇒ Set parameter 882	30%

- 2.2. Underfloor heating systems
The minimum pump speed for underfloor heating systems results from 75% of the maximum pump speed.

⇒

Tab.20 Example (without illustration)

⇒ Max. speed (read off)	50%
⇒ Min. speed (read off)	$0.75 * 50\% = 37.5\%$
⇒ Set parameter 882	37%



For more information, see
Total dynamic head Paramount, page 17

8.11 Emergency mode (Manual control)



Activation of manual control. If the manual control function is activated the boiler is controlled to the setpoint manual control. All the pumps are switched on. Additional requests e.g. for heating domestic water are ignored.

1. Press **OK**.
2. Request the menu item Maintenance.
3. Press **OK**.
4. Request the parameter Manual control (prog. no. 7140).
5. Press **OK**.
6. Select the parameter On.
7. Press **OK**.
8. Leave the programming level by pressing the **operating mode key for heating mode**.

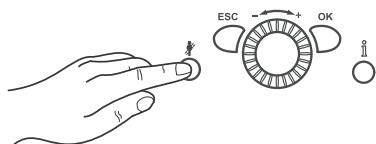
8.12 Chimney sweep function



The chimney sweep function is activated or deactivated using the **Chimney-sweep button**.

1. Press the **Chimney-sweep button** .
 - ⇒ The activated special function is displayed by the symbol  in the display.

i Important
If there is demand for heat from a coiled tubing storage tank, this demand will continue to be met while the emissions test function (chimney sweep function) is running.

9 Settings

9.1 List of parameters



See

- Subject to system configuration, not all parameters listed in the parameter list will be shown on the display.
- To reach the end user (Eu), Commissioning (C) and Engineer (E) setting levels:
 - 1 Press the **OK button**.
 - .
 - 2 Then press the **information button** for approx. 3 s.
 - .
 - 3 Select the circuit using the control knob.
 - .
 - 4 Confirm with the **OK button**.
 - .

Time of day and date	Prog. no.	Level	Standard value
Hours / minutes	1	Eu	01:00 (h:min)
Day / month	2	Eu	01.01 (day.month)
Year	3	Eu	2030 (year)
Start of summertime	5	E	25.03 (day.month)
End of summertime	6	E	25.10 (day.month)

Operator section	Prog. no.	Level	Standard value
Language	20	Eu	English
Info Temporarily Permanently	22	E	Temporarily
Contrast of display	25	Eu	—
Operation lock Off On	26	E	Off
Programming lock Off On	27	E	Off
Units °C, bar °F, PSI	29	Eu	°C, bar
Save basic settings ⁽¹⁾ No Yes	30	E	No
Activate basic settings ⁽²⁾ No Yes	31	E	No
Used as ⁽¹⁾ Room unit 1 Room unit 2 Room unit 3 Operator unit 1 Operator unit 2 Operator unit 3 Service unit	40	C	Room unit 1
Assignment device 1 ⁽³⁾ Heating circuit 1 Heating circuits 1 and 2 Heating circuits 1 and 3/P All heating circuits	42	C	Heating circuit 1
Operation HC2 ⁽¹⁾ Jointly with HC1 Independently	44	C	Jointly with HC1
Operation HC3/P ⁽¹⁾ Jointly with HC1 Independently	46	C	Jointly with HC1
Room temperature device 1 ⁽¹⁾ Heating circuit 1 only For all assigned HCs	47	C	For all assigned HCs
Occupancy button device 1 ⁽¹⁾ None Heating circuit 1 For all assigned HCs	48	C	For all assigned HCs

Operator section	Prog. no.	Level	Standard value
Readjustment room sensor ⁽¹⁾	54	E	0.0 °C
Software version	70	E	
(1) This parameter is only visible in the room device! (2) This parameter is only visible if a suitable standard setting is available in the operating unit! (3) This parameter is only visible in the room device, as the operating unit in the boiler is programmed permanently to the operating unit!			

Wireless ⁽¹⁾	Prog. no.	Level	Standard value
Room unit 1 Missing In operation No receipt'n Change batt	130	C	
Room unit 2 Missing In operation No receipt'n Change batt	131	C	
Room unit 3 Missing In operation No receipt'n Change batt	132	C	
Outside sensor Missing In operation No receipt'n Change batt	133	C	
Repeater Missing In operation No receipt'n Change batt	134	C	
Operator unit 1 Missing In operation No receipt'n Change batt	135	C	
Operator unit 2 Missing In operation No receipt'n Change batt	136	C	
Operator unit 3 Missing In operation No receipt'n Change batt	137	C	
Service unit Missing In operation No receipt'n Change batt	138	C	
Delete all devices No Yes	140	C	
(1) Parameter only visible, if wireless room device exists!			

Time program	Heating circuit 1 Prog. no.	Heating circuit 2 ⁽¹⁾ Prog. no.	Heating circuit 3 Prog. no.	Level	Standard value
Preselection Mo - Su Mo - Su Mo - Fr Sa - Su Monday Tuesday Wednesday Thursday Friday Saturday Sunday	500	520	540	Eu	Monday
1st phase on	501	521	541	Eu	06:00 (h/min)
1st phase off	502	522	542	Eu	22:00 (h/min)
2nd phase on	503	523	543	Eu	--:-- (h/min)
2nd phase off	504	524	544	Eu	--:-- (h/min)
3rd phase on	505	525	545	Eu	--:-- (h/min)
3rd phase off	506	526	546	Eu	--:-- (h/min)
Copy?	515	535	555	Eu	No
Default values No Yes	516	536	556	Eu	No
(1) Parameters only visible if heating circuit is installed.					

Time program heating circuit 4 / DHW	Prog. no.	Level	Standard value
Preselection Mo - Su Mo - Su Mo - Fr Sa - Su Monday Tuesday Wednesday Thursday Friday Saturday Sunday	560	Eu	Monday
1st phase on	561	Eu	05:00 (h/min)
1st phase off	562	Eu	22:00 (h/min)
2nd phase on	563	Eu	--:-- (h/min)
2nd phase off	564	Eu	--:-- (h/min)
3rd phase on	565	Eu	--:-- (h/min)
3rd phase off	566	Eu	--:-- (h/min)

Time program heating circuit 4 / DHW	Prog. no.	Level	Standard value
Copy?	575	Eu	No
Default values No Yes	576	Eu	No

Time program heating circuit 5	Prog. no.	Level	Standard value
Preselection Mo - Su Mo - Su Mo - Fr Sa - Su Monday Tuesday Wednesday Thursday Friday Saturday Sunday	600	Eu	Monday
1st phase on	601	Eu	06:00 (h/min)
1st phase off	602	Eu	22:00 (h/min)
2nd phase on	603	Eu	--:-- (h/min)
2nd phase off	604	Eu	--:-- (h/min)
3rd phase on	605	Eu	--:-- (h/min)
3rd phase off	606	Eu	--:-- (h/min)
Copy?	615	Eu	No
Default values No Yes	616	Eu	No

Holidays heating circuit	1 Prog. no.	2 ⁽¹⁾ Prog. no.	3 ⁽¹⁾ Prog. no.	Level	Standard value
Preselection Period 1 Period 2 Period 3 Period 4 Period 5 Period 6 Period 7 Period 8	641	651	661	Eu	Period 1
Start	642	652	662	Eu	—.— (day.month)
End	643	653	663	Eu	—.— (day.month)
Operating level Protection Reduced	648	658	668	Eu	Protection
(1) Parameters only visible if heating circuit is installed!					

Heating circuit	1 Prog. no.	2 ⁽¹⁾ Prog. no.	3 ⁽¹⁾ Prog. no.	Level	Standard value
Comfort setpoint	710	1010	1310	Eu	20.0 °C
Reduced setpoint	712	1012	1312	Eu	18 °C
Frost protection setpoint	714	1014	1314	Eu	10.0 °C
Heating curve slope	720	1020	1320	Eu	1,24
Heating curve displacement	721	1021	1321	E	2.0 °C
Heating curve adaption Off On	726	1026	1326	E	Off
Summer/winter heating limit	730	1030	1330	Eu	18°C
24-hour heating limit	732	1032	1332	E	0 °C
Flow temp setpoint min	740	1040	1340	E	8 °C
Flow temp setpoint max	741	1041	1341	E	80 °C
Flow temp setpoint room stat	742	1042	1342	E	--- °C
Swi-on ratio room stat	744	1044	1344	E	--- %
Delay heat request	746	1046	1346	E	0 s
Room influence	750	1050	1350	C	--- %
Room temp limitation	760	1060	1360	E	0.5 °C
Boost heating	770	1070	1370	E	--- °C
Quick setback 0: Off 1: To Reduced setpoint 2: To frost Prot setpoint	780	1080	1380	E	To Reduced setpoint
Optimum start control max	790	1090	1390	E	0 min
Optimum stop control max	791	1091	1391	E	0 min
Reduced setp increase start	800	1100	1400	E	--- °C
Reduced setp increase end	801	1101	1401	E	-15 °C

Heating circuit	1 Prog. no.	2 ⁽¹⁾ Prog. no.	3 ⁽¹⁾ Prog. no.	Level	Standard value
Continuous pump operation No Yes	809	1109	1409	E	No
Overtemp prot pump circuit Off On	820	1120	1420	E	Off
Mixing valve boost	830	1130	1430	E	5 °C
Actuator running time	834	1134	1434	E	140 s
Floor curing function 0: Off 1: Functional heating 2: Curing heating 3: Functional/curing heating 4: Curing/functional heating 5: Manually	850	1150	1450	E	Off
Floor curing setp manually	851	1151	1451	E	25 °C
Floor curing setp current	855	1155	1455	E	--- °C
Floor curing day current	856	1156	1456	E	---
Excess heat draw 0: Off 1: Heating mode 2: Always	861	1161	1461	E	Heating mode
With buffer No Yes	870	1170	1470	E	Yes
With prim contr/system pump No Yes	872	1172	1472	E	Yes
Pump speed reduction 0: Operating level 1: Characteristic 2: Temp differential nominal	880	1180	1480	E	Characteristic
Pump speed min	882	1182	1482	C	30 %
Pump speed max	883	1183	1483	C	80%
Curve readj at 50% speed	888	1188	1488	E	10 %
Flow setp readj speed ctrl No Yes	890	1190	1490	E	YesNo
Operating level changeover 0: Protection 1: Reduced 2: Comfort	898	1198	1498	E	Reduced
Optg mode changeover 0: None 1: Protection 2: Reduced 3: Comfort 4: Automatic	900	1200	1500	E	Protection
(1) Parameters only visible if heating circuit is installed!					

DHW	Prog. no.	Level	Standard value
Nominal setpoint	1610	Eu	55 °C
Reduced setpoint	1612	E	45 °C
Nominal setpoint max	1614	E	65 °C
Release 24h/day Time programs HCs Time program 4/DHW	1620	Eu	Time program 4/DHW
Charging priority 0: Absolute 1: Shifting 2: None 3: MC shifting, PC absolute	1630	E	MC shifting, PC absolute
Legionella function 0: Off 1: Periodically 2: Fixed weekday	1640	E	Fixed weekday
Legionella funct periodically	1641	E	7
Legionella funct weekday 1: Monday 2: Tuesday 3: Wednesday 4: Thursday 5: Friday 6: Saturday 7: Sunday	1642	E	Sunday
Legionella funct time	1644	E	---
Legionella funct setpoint	1645	E	65 °C
Legionella funct duration	1646	E	--- min
Legionella funct circ pump Off On	1647	E	On
Circulating pump release 1: Time program 3/HCP 2: DHW release 3: Time program 4/DHW 4: Time program 5	1660	C	DHW release

DHW	Prog. no.	Level	Standard value
Circulating pump cycling Off On	1661	C	On
Circulation setpoint	1663	E	55 °C
Optg mode changeover 0: None 1: Off 2: On	1680	E	Off

Consumer circuit / Swimming pool circuit	Consumer circuit 1 Prog. no.	Consumer circuit 2 Prog. no.	Swimming pool circuit Prog. no.	Level	Standard value
Flow temp setp cons request	1859	1909	1959	C	70 °C
DHW charging priority No Yes	1874	1924	1974	E	Yes
Excess heat draw Off On	1875	1925	1975	E	On
With buffer No Yes	1878	1928	1978	E	Yes
With prim contr/system pump No Yes	1880	1930	1980	E	Yes

Swimming pool	Prog. no.	Level	Standard value
Setpoint solar heating	2055	Eu	26 °C
Setpoint source heating	2056	Eu	22 °C
Charging priority solar 1: Priority 1 2: Priority 2 3: Priority 3	2065	E	Priority 3
Swimming pool temp max	2070	E	32 °C
With solar integration No Yes	2080	E	Yes

Primary control/feed pump	Prog. no.	Level	Standard value
Flow temp setpoint min	2110	E	8 °C
Flow temp setpoint max	2111	E	80 °C
Syst pump on heat gen lock Off On	2121	E	Off
Mixing valve boost	2130	E	0 °C
Actuator running time	2134	E	140 s
Primary contr/system pump 0: Before buffer 1: After buffer	2150	E	After buffer

Boiler	Prog. no.	Level	Standard value
Release below outside temp	2203	E	--- °C
Full charging buffer Off On	2208	E	Off
Setpoint min	2210	E	20 °C
Setpoint max	2212	E	85 °C
Setpoint manual control	2214	Eu	60 °C
Burner running time min	2241	E	1 min
Burner off time min	2243	E	7 min
SD burner off time	2245	E	20 °C
Pump overrun time	2250	E	2 min
Pump overr time after DHW	2253	E	1 min
Frost prot plant boiler pump Off On	2300	E	On
Boiler pump on heat gen lock Off On	2301	E	Off
Impact heat generation lock 1: Heating mode only 2: Heating and DHW mode	2305	E	Heating mode only

Boiler	Prog. no.	Level	Standard value
Temp differential max	2316	C	- - -
Temp differential nominal	2317	C	15 °C
Pump modulation 0: None 1: Demand 2: Boiler setpoint 3: Temp differential nominal 4: Burner output	2320	E	Demand
Pump speed min	2322	E	10 %
Pump speed max	2323	E	100 %
Output nominal	2330	E	Paramount 30: 30 kW; Paramount 40: 38 kW Paramount 50: 50 kW; Paramount 60 : 58 kW; Paramount 80: 77 kW; Paramount 95: 95 kW; Paramount 115: 115 kW
Output basic stage	2331	E	Paramount 30: 6 kW; Paramount 40: 9 kW Paramount 50: 10 kW; Paramount 60: 12 kW; Paramount 80: 21 kW; Paramount 95: 20 kW; Paramount 115: 25 kW
Output at pump speed min	2334	E	25 %
Output at pump speed max	2335	E	100 %
Fan output heating max ⁽¹⁾	2441	E	Paramount 30: 30 kW; Paramount 40: 38 kW Paramount 50: 50 kW; Paramount 60: 58 kW; Paramount 80: 77 kW; Paramount 95: 95 kW; Paramount 115: 115 kW
Fan output full charging max ⁽¹⁾	2442	E	Paramount 30: 30 kW; Paramount 40: 38 kW Paramount 50: 50 kW; Paramount 60: 58 kW; Paramount 80: 77 kW; Paramount 95: 95 kW; Paramount 115: 115 kW
Fan output DHW max ⁽¹⁾	2444	E	Paramount 30: 30 kW; Paramount 40: 38 kW Paramount 50: 50 kW; Paramount 60: 58 kW; Paramount 80: 77 kW; Paramount 95: 95 kW; Paramount 115: 115 kW
Controller delay 0: Off 1: Heating mode only 2: DHW mode only 3: Heating and DHW mode	2450	E	Heating mode only
Controller delay fan output ⁽¹⁾	2452	E	Paramount 30: 10.0 kW; Paramount 40: 14.0 kW Paramount 50: 20,0 kW; Paramount 60: 22,5 kW; Paramount 80: 34,5 kW; Para- mount 95: 36.0 kW; Paramount 115: 40.0 kW

Boiler	Prog. no.	Level	Standard value
Controller delay duration	2453	E	40 s
Switching diff on HCs	2454	E	4 °C
Switching diff off min HCs	2455	E	5 °C
Switching diff off max HCs	2456	E	10 °C
Switching diff on DHW	2460	E	5 °C
Switching diff off min DHW	2461	E	6 °C
Switching diff off max DHW	2462	E	8 °C
Delay heat req special op	2470	E	0 s
Static press superv sh'down 0: Start prevention 1: Lockout position	2480	E	Lockout position
Gas energy metering Off On	2550	C	Off
Gas energy metering readj	2551	C	1.0
Off delay flue gas damper	2560	E	30 s
(1) the kW settings are approximate values. Exact values can be determined by the gas meter for example.			

Cascade	Prog. no.	Level	Standard value
Lead strategy 1: Late on, early off 2: Late on, late off 3: Early on, late off	3510	E	Late on, late off
Release integral source seq	3530	E	50 °C*min
Reset integral source seq	3531	E	20 °C*min
Restart lock	3532	E	300 s
Switch on delay	3533	E	10 min
Switch-on delay DHW	3535	E	2 min
Auto source seq ch'over	3540	E	100 h
Auto source seq exclusion 0: None 1: First 2: Last 3: First and last	3541	E	None
Leading source 1: Source 1 2: Source 2 3: Source 3 4: Source 4 5: Source 5 6: Source 6 7: Source 7 8: Source 8 9: Source 9 10: Source 10 11: Source 11 12: Source 12 13: Source 13 14: Source 14 15: Source 15 16: Source 16	3544	E	Source 1
Return setpoint min	3560	E	8 °C
Temp differential min	3590	E	--- °C

Solar	Prog. no.	Level	Standard value
Temp diff on	3810	C	8 °C
Temp diff off	3811	C	4 °C
Charg temp min DHW st tank	3812	E	--- °C
Temp diff on buffer	3813	E	--- °C
Temp diff off buffer	3814	E	--- °C
Charging temp min buffer	3815	E	--- °C
Temp diff on swi pool	3816	E	--- °C
Temp diff off swi pool	3817	E	--- °C
Charging temp min swi pool	3818	E	--- °C
Charging prio storage tank 0: None 1: DHW storage tank 2: Buffer storage tank	3822	E	DHW storage tank
Charging time relative prio	3825	E	--- min
Waiting time relative prio	3826	E	5 min
Waiting time parallel op	3827	E	--- min
Delay secondary pump	3828	E	60 s
Collector start function	3830	E	---
Min run time collector pump	3831	E	20 s
Collector start function on	3832	E	07:00 (h:min)
Collector start function off	3833	E	19:00 (h:min)

Solar	Prog. no.	Level	Standard value
Collector start funct grad	3834	E	--- min/°C
Collector frost protection	3840	E	--- °C
Collector overtemp prot	3850	E	--- °C
Evaporation heat carrier	3860	E	130 °C
Pump speed min	3870	E	10 %
Pump speed max	3871	E	100 %
Antifreeze 1: None 2: Ethylene glycol 3: Propylene glycol 4: Ethyl and propyl glycol	3880	E	Propylene glycol
Antifreeze concentration	3881	E	50 %
Pump capacity	3884	E	200 l/h
Pulse unit yield	3887	E	10 l





Solid fuel boiler	Prog. no.	Level	Standard value
Locks other heat sources Off On	4102	E	Off
Setpoint min	4110	E	65 °C
Temp diff on	4130	E	8 °C
Temp diff off	4131	E	4 °C
Comparative temp 1: DHW sensor B3 2: DHW sensor B31 3: Buffer sensor B4 4: Buffer sensor B41 5: Flow temp setpoint 6: Setpoint min	4133	E	Buffer sensor B41
Pump overrun time	4140	E	20 min

Buffer storage tank	Prog. no.	Level	Standard value
Auto generation lock 0: None 1: With B4 2: With B4 and B42/B41	4720	E	With B4
Auto heat gen lock SD	4721	E	5 °C
Temp diff buffer/HC	4722	E	-3 °C
Min st tank temp heat mode	4724	E	--- °C
Charging temp max	4750	E	80 °C
Recooling temp	4755	E	60 °C
Recooling DHW/HCs Off On	4756	E	Off
Recooling collector 0: Off 1: Summer 2: Always	4757	E	Off
With solar integration No Yes	4783	E	Yes
Temp diff on return div	4790	E	8 °C
Temp diff off return div	4791	E	4 °C
Compar temp return div 1: With B4 2: With B41 3: With B42	4795	E	With B4
Optg action return diversion 1: Temp decrease 2: Temp increase	4796	E	Temp increase
Partial charging setpoint	4800	E	---
Full charging 0: Off 1: Heating mode 2: Always	4810	E	Off
Full charging temp min	4811	E	8 °C
Full charging sensor 1: With B4 2: With B42/B41	4813	E	With B42/B41

Domestic water storage tank ⁽¹⁾	Prog. no.	Level	Standard value
Forward shift charging	5011	E	60 min
Flow setpoint boost	5020	E	18 °C
Transfer boost	5021	E	10 °C

Domestic water storage tank⁽¹⁾	Prog. no.	Level	Standard value
Type of charging 1: Recharging 2: Full charging 3: Full charging legio 4: Full charg 1st time day 5: Full charg 1st time legio	5022	E	Full charging
Switching diff	5024	E	4 °C
Charging time limitation	5030	E	120 min
Discharging protection 0: Off 1: Always 2: Automatically	5040	E	Automatically
Discharg protec after charg Off On	5042		Off
Charging temp max	5050	E	69 °C
Recooling temp	5055	E	80 °C
Recooling collector 0: Off 1: Summer 2: Always	5057	E	Off
Ei imm heater optg mode 1: Substitute 2: Summer 3: Always	5060	E	Substitute
Ei immersion heater release 1: 24h/day 2: DHW release 3: Time program 4/DHW	5061	E	DHW release
Ei immersion heater control 1: External thermostat 2: DHW sensor	5062	E	DHW sensor
Automatic push Off On	5070	E	On
Excess heat draw Off On	5085	E	On
With buffer No Yes	5090	E	Yes
With prim contr/system pump No Yes	5092	E	Yes
With solar integration No Yes	5093	E	Yes
Pump speed min	5101	E	0 %
Pump speed max	5102	E	100 %
Speed Xp	5103	E	15 °C
Speed Tn	5104	E	60 s
Speed Tv	5105	E	5 s
Transfer strategy 0: Off 1: Always 2: DHW release	5130	E	Always
Interm circ boost recharging	5139	E	5 °C
Intermediate circuit boost	5140	E	2 °C
Excess interm circ temp max	5141	E	2 °C
Flow setp compensation delay	5142	E	30 s
Flow setp compensation Xp	5143	E	50 °C
Flow setp compensation Tn	5144	E	30 s
Flow setp compensation Tv	5145	E	30 s
Full charging with B36 No Yes	5146	E	No
Min start temp diff Q33	5148	E	-3 °C
Excess interm circ temp del	5151	E	30 s
(1) Parameters depend on the hydraulic System!			

Configuration	Prog. no.	Level	Standard value
Heating circuit 1 Off On	5710	C	On
Heating circuit 2 Off On	5715	C	Off
Heating circuit 3 Off On	5721	C	Off

Configuration	Prog. no.	Level	Standard value
DHW sensor 1: DHW sensor B3 2: Thermostat	5730	E	DHW sensor B3
DHW ctrl elem Q3 0: No charging request 1: Charging pump 2: Diverting valve	5731	E	Charging pump
Basic position DHW div valve 0: Last request 1: Heating circuit 2: DHW	5734	E	Heating circuit
DHW separate circuit Off On	5736	E	Off
Optg action DHW div valve 0: Position on DHW 1: Position on heating circuit	5737	E	Position on DHW
Ctrl boiler pump/DHW valve 0: All requests 1: Request HC1/DHW only	5774	E	All requests
Boiler pump at DHW Off On	5775	E	On
Solar controlling element 1: Charging pump 2: Diverting valve	5840	E	Diverting valve
External solar exchanger 1: Jointly 2: DHW storage tank 3: Buffer storage tank	5841	E	Jointly
Combi storage tank No Yes	5870	E	No
Relay output QX1 0: None 1: Circulating pump Q4 2: El imm heater DHW K6 3: Collector pump Q5 4: Cons circuit pump VK1 Q15 5: Boiler pump Q1 7: Alarm output K10 11: Heat circuit pump HC3 Q20 12: Cons circuit pump VK2 Q18 13: System pump Q14 14: Heat gen shutoff valve Y4 15: Solid fuel boiler pump Q10 16: Time program 5 K13 17: Buffer return valve Y15 18: Solar pump ext exch K9 19: Solar ctrl elem buffer K8 20: Solar ctrl elem swi pool K18 22: Swimming pool pump Q19 25: Cascade pump Q25 26: St tank transfer pump Q11 27: DHW mixing pump Q35 28: DHW interm circ pump Q33 29: Heat request K27 33: Heat circuit pump HC1 Q2 34: Heat circuit pump HC2 Q6 35: DHW ctrl elem Q3 40: Status output K35 41: Status information K36 42: Flue gas damper K37 43: Fan shutdown K38	5890	C	None
Relay output QX2  See Parameters see Relay output QX1 (prog. no. 5890)!	5891	C	Heat circuit pump HC1 Q2
Relay output QX3  See Parameters see Relay output QX1 (prog. no. 5890)!	5892	C	DHW ctrl elem Q3
Sensor input BX1 0: None 1: DHW sensor B31 2: Collector sensor B6 4: DHW circulation sensor B39 5: Buffer sensor B4 6: Buffer sensor B41 8: Common flow sensor B10 9: Solid fuel boiler sensor B22 10: DHW charging sensor B36 11: Buffer sensor B42 12: Common return sensor B73 13: Cascade return sensor B70 14: Swimming pool sensor B13 16: Solar flow sensor B63 17: Solar return sensor B64	5930	C	Collector sensor B6
Sensor input BX2  See Parameters see Sensor input BX1 (prog. no. 5930)!	5931	C	DHW sensor B31
Sensor input BX3  See Parameters see Sensor input BX1 (prog. no. 5930)!	5932	C	Buffer sensor B4

Configuration	Prog. no.	Level	Standard value
Function input H1 0: {None 1: Optg mode change HCs+DHW 2: Optg mode changeover DHW 3: Optg mode changeover HCs 4: Optg mode changeover HC1 5: Optg mode changeover HC2 6: Optg mode changeover HC3 7: Heat generation lock 8: Error/alarm message 9: Consumer request VK1 10: Consumer request VK2 11: Release swi pool source heat 12: Excess heat discharge 13: Release swi pool solar 14: Operating level DHW 15: Operating level HC1 16: Operating level HC2 17: Operating level HC3 18: Room thermostat HC1 19: Room thermostat HC2 20: Room thermostat HC3 22: DHW thermostat 24: Pulse count 28: Checkb sign flue gas damper 29: Start prevention 51: Consumer request VK1 10V 52: Consumer request VK2 10V 58: Output request 10V 60: Temp measurement 10V	5950	C	None
Contact type H1 NC NO	5951	C	NO
Voltage value 1 H1	5953	E	0
Function value 1 H1	5954	E	0
Voltage value 2 H1	5955	E	10
Function value 2 H1	5956	E	1000
Function input H4 0: None 1: Optg mode change HCs+DHW 2: Optg mode changeover DHW 3: Optg mode changeover HCs 4: Optg mode changeover HC1 5: Optg mode changeover HC2 6: Optg mode changeover HC3 7: Heat generation lock 8: Error/alarm message 9: Consumer request VK1 10: Consumer request VK2 11: Release swi pool source heat 12: Excess heat discharge 13: Release swi pool solar 14: Operating level DHW 15: Operating level HC1 16: Operating level HC2 17: Operating level HC3 18: Room thermostat HC1 19: Room thermostat HC2 20: Room thermostat HC3 22: DHW thermostat 24: Pulse count 28: Checkb sign flue gas damper 29: Start prevention 50: Flow measurement Hz	5970	C	None
Contact type H4 0: NC 1: NO	5971	C	NO
Frequency value 1 H4	5973	E	0
Function value 1 H4	5974	E	0
Frequency value 2 H4	5975	E	0
Function value 2 H4	5976	E	0
Function input H5 0: None 1: Optg mode change HCs+DHW 2: Optg mode changeover DHW 3: Optg mode changeover HCs 4: Optg mode changeover HC1 5: Optg mode changeover HC2 6: Optg mode changeover HC3 7: Heat generation lock 8: Error/alarm message 9: Consumer request VK1 10: Consumer request VK2 11: Release swi pool source heat 12: Excess heat discharge 13: Release swi pool solar 14: Operating level DHW 15: Operating level HC1 16: Operating level HC2 17: Operating level HC3 18: Room thermostat HC1 19: Room thermostat HC2 20: Room thermostat HC3 22: DHW thermostat 24: Pulse count 28: Checkb sign flue gas damper	5977	C	None
Contact type H5 0: NC 1: NO	5978	C	NO
Function output P1 0: None 1: Boiler pump Q1 2: DHW pump Q3 3: DHW interm circ pump Q33 4: Heat circuit pump HC1 Q2 5: Heat circuit pump HC2 Q6 6: Heat circuit pump HC3 Q20 7: Collector pump Q5 8: Solar pump ext exch K9 9: Solar pump buffer K8 10: Solar pump swi pool K18	6085	E	Heat circuit pump HC1 Q2None
Signal logic output P1 0: Standard 1: Inverted	6086	E	Inverted
Sensor type collector 1: NTC 2: Pt 1000	6097	E	NTC
Readjustm collector sensor	6098	E	0 °C
Readjustm outside sensor	6100	E	0.0 °C
Time constant building	6110	C	10 h
Central setp compensation	6117	E	10 °C

Configuration	Prog. no.	Level	Standard value
Frost protection plant Off On	6120	E	On
Water pressure min	6181	E	0.7 bars
Save sensors No Yes	6200	C	No
Reset to default parameters	6205	C	No
Check no. heat source 1	6212	E	
Check no. heat source 2	6213	E	
Check no. storage tank	6215	E	
Check no. heating circuits	6217	E	
Software version	6220	E	
Info 1 OEM	6230	E	
Info 2 OEM	6231	E	
Parameter set number OEM	6236	E	
Info 3 OEM	6258	E	
Info 4 OEM	6259	E	

LPB system	Prog. no.	Level	Standard value
Device address	6600	C	1
Segment address	6601	E	0
Bus power supply function 0: Off 1: Automatically	6604	E	Automatically
Bus power supply state Off On	6605	E	
Display system messages No Yes	6610	E	Yes
System message to alarm relay No Yes	6611	C	Yes
Alarm delay	6612	E	- - - min
Action changeover functions 0: Segment 1: System	6620	E	System
Summer changeover 0: Locally 1: Centrally	6621	E	Locally
Optg mode changeover 0: Locally 1: Centrally	6623	E	Centrally
Manual source lock 0: Locally 1: Segment	6624	E	Locally
DHW assignment 0: Local HCs 1: All HCs in segment 2: All HCs in segment All HCs in system	6625	E	All HCs in system
Note OT limit ext source No Yes	6632	E	No
Clock mode 0: Autonomously 1: Slave without remote setting 2: Slave with remote setting 3: Master	6640	C	Slave with remote setting
Outside temp source	6650	E	



Modbus	Prog. no.	Level	Standard value
Slave address	6651	E	- - -
Baud rate	6652	E	19,200
Parity	6653	E	Even
Stop bit	6654	E	1









Fault	Prog. no.	Level	Standard value
Message	6700	Eu	
SW diagnostic code	6705	Eu	









Fault	Prog. no.	Level	Standard value
Burn ctrl phase lockout pos	6706	Eu	
Reset alarm relay No Yes	6710	C	No
Flow temp 1 alarm	6740	E	--- min
Flow temp 2 alarm	6741	E	--- min
Flow temp 3 alarm	6742	E	--- min
Boiler temp alarm	6743	E	--- min
DHW charging alarm	6745	E	--- h
History 1 • Date / Time • Fault code 1	6800	E	
SW diagnostic code 1 • Burner control phase 1	6805	E	
History 2 • Date / Time • Fault code 2	6810	E	
SW diagnostic code 2 • Burner control phase 2	6815	E	
History 3 • Date / Time • Fault code 3	6820	E	
SW diagnostic code 3 • Burner control phase 3	6825	E	
.	.	.	
.	.	.	
.	.	.	
History 20 • Date / Time • Fault code 20	6990	E	
SW diagnostic code 20 • Burner control phase 20	6995	E	



Maintenance/special operation	Prog. no.	Level	Standard value
Burner hours interval	7040	E	--- h
Burn hrs since maintenance	7041	E	--- h
Burner start interval	7042	E	---
Burn starts since maint	7043	E	---
Maintenance interval	7044	E	--- months
Time since maintenance	7045	E	--- months
Fan speed ionization current	7050	E	0 rpm
Message ionization current No Yes	7051	E	No
Chimney sweep function Off On	7130	Eu	Off
Manual control Off On	7140	EU	Off
Controller stop function Off On	7143	E	Off
Controller stop setpoint	7145	E	
Forced heat draw DHW Off On	7165	E	Off
Commissioning wizard Off On	7167	E	On

Maintenance/special operation	Prog. no.	Level	Standard value
Telephone customer service	7170	C	---
PStick storage pos • PStick Reg data set	7250	E	0
PStick command 0: No operation 1: Reading from stick 2: Writing on stick	7252	E	No operation
PStick progress • PStick status 0: No stick 1: Stick ready 2: Writing on stick 3: Reading from stick 4: EMC test active 5: Writing error 6: Reading error 7: Incompatible data set 8: Wrong stick type 9: Stick format error 10: Check data set 11: Data set disabled 12: Reading disabled	7253	E	0 %

Configuration of extension modules	Prog. no.	Level	Standard value
Function extension module 1 0: None 1: Multifunctional 2: Heating circuit 1 3: Heating circuit 2 4: Heating circuit 3 6: Solar DHW 7: Primary contr/system pump	7300	C	Heating circuit 2
Relay output QX21 module 1 0: None 1: Circulating pump Q4 2: El imm heater DHW K6 3: Collector pump Q5 4: Cons circuit pump VK1 Q15 5: Boiler pump Q1 7: Alarm output K10 11: Heat circuit pump HC3 Q20 12: Cons circuit pump VK2 Q18 13: System pump Q14 14: Heat gen shutoff valve Y4 15: Solid fuel boiler pump Q10 16: Time program 5 K13 17: Buffer return valve Y15 18: Solar pump ext exch K9 19: Solar ctrl elem buffer K8 20: Solar ctrl elem swi pool K18 22: Swimming pool pump Q19 25: Cascade pump Q25 26: St tank transfer pump Q11 27: DHW mixing pump Q35 28: DHW interm circ pump Q33 29: Heat request K27 33: Heat circuit pump HC1 Q2 34: Heat circuit pump HC2 Q6 35: DHW ctrl elem Q3 40: Status output K35 41: Status information K36 43: Fan shutdown K38	7301	C	None
Relay output QX22 module 1  See Parameters see Relay output QX21 module 1 (prog. no. 7301)!	7302	C	None
Relay output QX23 module 1  See Parameters see Relay output QX21 module 1 (prog. no. 7301)!	7303	C	None
Sensor input BX21 module 1 0: None 1: DHW sensor B3 2: Collector sensor B6 4: DHW circulation sensor B39 5: Buffer sensor B4 6: Buffer sensor B41 8: Common flow sensor B10 9: Solid fuel boiler sensor B22 10: DHW charging sensor B36 11: Buffer sensor B42 12: Common return sensor B73 13: Cascade return sensor B70 14: Swimming pool sensor B13 16: Solar flow sensor B63 17: Solar return sensor B64	7307	C	None
Sensor input BX22 module 1  See Parameters see Relay output QX21 module 1 (prog. no. 7307)!	7308	C	None
Function input H2/H21 module 1 0: None 1: Optg mode change HCs+DHW 2: Optg mode changeover DHW 3: Optg mode changeover HCs 4: Optg mode changeover HC1 5: Optg mode changeover HC2 6: Optg mode changeover HC3 7: Heat generation lock 8: Error/alarm message 9: Consumer request VK1 10: Consumer request VK2 11: Release swi pool source heat 12: Excess heat discharge 13: Release swi pool solar 14: Operating level DHW 15: Operating level HC1 16: Operating level HC2 17: Operating level HC3 18: Room thermostat HC1 19: Room thermostat HC2 20: Room thermostat HC3 21: DHW flow switch 22: DHW thermostat 25: Limit thermostat HC 29: Start prevention 51: Consumer request VK1 10V 52: Consumer request VK2 10V 58: Output request 10V	7321	C	None

Configuration of extension modules	Prog. no.	Level	Standard value
Contact type H2/H21 module 1 NC NO	7322	C	NO
Input value 1 H2/H21 module 1	7324	E	0
Funct value 1 H2/H21 module 1	7325	E	0
Input value 2 H2/H21 module 1	7326	E	10
Funct value 2 H2/H21 module 1	7327	E	1000
Funct input EX21 module 1 None Limit thermostat HC	7342	C	None
Funct output UX21 module 1 0: None 1: Boiler pump Q1 2: DHW pump Q3 3: DHW interm circ pump Q33 4: Heat circuit pump HC1 Q2 5: Heat circuit pump HC2 Q6 6: Heat circuit pump HC3 Q20 7: Collector pump Q5 8: Solar pump ext exch K9 9: Solar pump buffer K8 10: Solar pump swi pool K18	7348	E	None
Sign logic out UX21 module1 0: Standard 1: Inverted	7349	C	Standard
Signal output UX21 module 1 0: 10 V 1: PWM	7350	E	PWM
Funct output UX22 module 1  See Parameters see Funct output UX21 module 1 (prog. no. 7348)!	7355	E	None
Sign logic out UX22 module1 0: Standard 1: Inverted	7356	C	Standard
Signal output UX22 module 1 0: 10 V 1: PWM	7357	E	PWM
Function extension module 2  See Parameters see Function extension module 1 (prog. no. 7300).	7375	C	Heating circuit 3
Relay output QX21 module 2  See Parameters see Relay output QX21 module 1 (prog. no. 7301)!	7376	C	None
Relay output QX22 module 2  See Parameters see Relay output QX21 module 1 (prog. no. 7301)!	7377	C	None
Relay output QX23 module 2  See Parameters see Relay output QX21 module 1 (prog. no. 7301)!	7378	C	None
Sensor input BX21 module 2  See Parameters see Sensor input BX21 module 1 (prog. no. 7307)!	7382	C	None
Sensor input BX22 module 2  See Parameters see Sensor input BX21 module 1 (prog. no. 7307)!	7383	C	None
Function input H2/H21 module 2  See Parameters see Function input H2/H21 module 1 (prog. no. 7321)!	7396	C	Optg mode change HCs+DHW

Configuration of extension modules	Prog. no.	Level	Standard value
Contact type H2/H21 module 2 0: NC 1: NO	7397	E	NO
Input value 1 H2/H21 module 2	7399	E	0
Funct value 1 H2/H21 module 2	7400	E	0
Input value 2 H2/H21 module 2	7401	E	10
Funct value 2 H2/H21 module 2	7402	E	1000
Funct input EX21 module 2 0: None 25: Limit thermostat HC	7417	C	None
Funct output UX21 module 2  See Parameters see Funct output UX21 module 1 (prog. no. 7348)!	7423	E	None
Sign logic out UX21 module 2 0: Standard 1: Inverted	7424	C	Standard
Signal output UX21 module 2 0: 10 V 1: PWM	7425	E	PWM
Funct output UX22 module 2  See Parameters see Funct output UX21 module 1 (prog. no. 7348)!	7430	E	None
Sign logic out UX22 module 2 0: Standard 1: Inverted	7431	C	Standard
Signal output UX22 module 2 0: 10 V 1: PWM	7432	E	PWM
Function extension module 3  See Parameters see Function extension module 1 (prog. no. 7300).	7450	C	None
Relay output QX21 module 3  See Parameters see Relay output QX21 module 1 (prog. no. 7301)!	7451	C	None
Relay output QX22 module 3  See Parameters see Relay output QX21 module 1 (prog. no. 7301)!	7452	C	None
Relay output QX23 module 3  See Parameters see Relay output QX21 module 1 (prog. no. 7301)!	7453	C	None
Sensor input BX21 module 3  See Parameters see Sensor input BX21 module 1 (prog. no. 7307)!	7457	C	None
Sensor input BX22 module 3  See Parameters see Sensor input BX21 module 1 (prog. no. 7307)!	7458	C	None
Function input H2/H21 module 3  See Parameters see Function input H2/H21 module 1 (prog. no. 7321)!	7471	C	None
Contact type H2/H21 module 3 0: NC 1: NO	7472	C	NO



Configuration of extension modules	Prog. no.	Level	Standard value
Input value 1 H2/H21 module 3	7474	C	0
Funct value 1 H2/H21 module 3	7475	C	0
Input value 2 H2/H21 module 3	7476	C	10
Funct value 2 H2/H21 module 3	7477	C	1000
Funct input EX21 module 3 0: None 25: Limit thermostat HC	7492	C	None
Funct output UX21 module 3  See Parameters see Funct output UX21 module 1 (prog. no. 7348)!	7498	C	None
Sign logic out UX21 module 3 0: Standard 1: Inverted	7499	C	Standard
Signal output UX21 module 3 0: 10 V 1: PWM	7500	C	PWM
Funct output UX22 module 3  See Parameters see Funct output UX21 module 1 (prog. no. 7348)!	7505	C	None
Sign logic out UX22 module 3 0: Standard 1: Inverted	7506	C	Standard
Signal output UX22 module 3 0: 10 V 1: PWM	7507	C	PWM

Input/output test	Prog. no.	Level	Standard value
Relay test 0: No test 1: Everything off 2: Relay output QX1 3: Relay output QX2 4: Relay output QX3 5: Relay output QX21 module 1 6: Relay output QX22 module 1 7: Relay output QX23 module 1 8: Relay output QX21 module 2 9: Relay output QX22 module 2 10: Relay output QX23 module 2 11: Relay output QX21 module 3 12: Relay output QX22 module 3 13: Relay output QX23 module 3	7700	C	No test
Output test P1	7713	C	--- %
PWM signal P1	7714	C	
Outside temp B9	7730	C	
DHW temp B3/B38	7750	C	
Boiler temp B2	7760	C	
Output test UX21 module 1	7780	C	
Output signal UX21 module 1 0: None 1: Closed (ooo), Open (---) 2: Pulse 3: Frequency Hz 4: Voltage V 5: PWM %	7781	C	
Output test UX22 module 1	7782	C	
Output signal UX22 module 1 0: None 1: Closed (ooo), Open (---) 2: Pulse 3: Frequency Hz 4: Voltage V 5: PWM %	7783	C	
Output test UX21 module 2	7784	C	--- %
Output signal UX21 module 2 0: None 1: Closed (ooo), Open (---) 2: Pulse 3: Frequency Hz 4: Voltage V 5: PWM %	7785	C	None
Output test UX22 module 2	7786	C	
Output signal UX22 module 2 0: None 1: Closed (ooo), Open (---) 2: Pulse 3: Frequency Hz 4: Voltage V 5: PWM %	7787	C	
Output test UX21 module 3	7788	C	
Output signal UX21 module 3 0: None 1: Closed (ooo), Open (---) 2: Pulse 3: Frequency Hz 4: Voltage V 5: PWM %	7789	C	
Output test UX22 module 3	7790	C	

Input/output test	Prog. no.	Level	Standard value
Output signal UX22 module 3 0: None 1: Closed (ooo), Open (---) 2: Pulse 3: Frequency Hz 4: Voltage V 5: PWM %	7791	C	
Sensor temp BX1	7820	C	
Sensor temp BX2	7821	C	
Sensor temp BX3	7822	C	
Sensor temp BX21 module 1	7830	C	
Sensor temp BX22 module 1	7831	C	
Sensor temp BX21 module 2	7832	C	
Sensor temp BX22 module 2	7833	C	
Sensor temp BX21 module 3	7834	C	
Sensor temp BX22 module 3	7835	C	
Voltage signal H1	7840	C	
Contact state H1 Open 1: Closed	7841	C	
Voltage signal H2/H21 module 1 Contact state H2/H21 module 1 0: Open 1: Closed	7845	C	
Voltage signal H2/H21 module 2 Contact state H2/H21 module 2 0: Open 1: Closed	7848	C	
Voltage signal H2/H21 module 3 Contact state H2/H21 module 3 0: Open 1: Closed	7851	C	
Frequency H4	7862	C	
Contact state H4 0: Open 1: Closed	7860	C	
Contact state H5 0: Open 1: Closed	7865	C	
Contact state H6 0: Open 1: Closed	7872	C	
Input EX21 module 1	7950	C	
Input EX21 module 2	7951	C	
Input EX21 module 3	7952	C	

Status	Prog. no.	Level	Standard value
State heating circuit 1	8000	I	
State heating circuit 2	8001	I	
State heating circuit 3	8002	I	
State DHW	8003	I	
State boiler	8005	I	
State solar	8007	I	
State solid fuel boiler	8008	I	
State burner	8009	I	
State buffer	8010	I	
State swimming pool	8011	I	

Diagnostics cascade	Prog. no.	Level	Standard value
Priority/state source 1 0: Missing 1: Faulty 2: Manual control active 3: Heat generation lock active 4: Chimney sweep funct active 5: Temporarily unavailable 6: Outside temp limit active 7: Not released 8: Released	8100	C	
Priority/state source 2  See Parameters see Priority/state source 1 (prog. no. 8100)!	8102	C	

Diagnosics cascade	Prog. no.	Level	Standard value
Priority/state source 3	8104	C	
 See Parameters see Priority/state source 1 (prog. no. 8100)!			
.	.	.	
.	.	.	
.	.	.	
Priority/state source 16	8130	C	
 See Parameters see Priority/state source 1 (prog. no. 8100)!			
Cascade flow temp	8138	C	
Cascade flow temp setp	8139	C	
Cascade return temp	8140	C	
Cascade return temp setp	8141	C	
Source seq ch'over current	8150	C	

Diagnosics heat generation	Prog. no.	Level	Standard value
Boiler pump Q1	8304	E	
Boiler pump speed	8308	E	
Control temperature	8310	C	
Control setpoint	8311	C	
Boiler switching point	8312	C	
Control sensor 0: None 1: Boiler sensor B2 2: Return sensor B7 3: DHW charging sensor B36 4: DHW outlet sensor B38 5: DHW circulation sensor B39 6: Cascade sensor B10/B70	8313	E	
Boiler return temp	8314	C	
Fan speed	8323	C	
Set point fan	8324	C	
Current fan control	8325	C	
Burner modulation	8326	C	
Ionization current	8329	C	
Hours run 1st stage Start counter 1st stage	8330	Eu C	
Hours run heating mode	8338	Eu	
Hours run DHW	8339	Eu	
Total gas energy heating	8378	Eu	
Total gas energy DHW	8379	Eu	
Total gas energy	8380	Eu	
Gas energy heating	8381	Eu	
Gas energy DHW	8382	Eu	
Gas energy	8383	Eu	
Current phase number	8390	E	
Collector pump 1	8499	C	
Solar ctrl elem buffer	8501	E	
Solar ctrl elem swi pool	8502	E	
Speed collector pump 1	8505	E	
Speed solar pump ext exch	8506	E	
Speed solar pump buffer	8507	E	
Speed solar pump swi pool	8508	E	
Collector temp 1	8510	C	
Collector temp 1 max	8511	C	
Collector temp 1 min	8512	C	

Diagnostics heat generation	Prog. no.	Level	Standard value
dt collector 1/DHW	8513	C	
dt collector 1/buffer	8514	C	
dt collector 1/swimming pool	8515	C	
Solar flow temp	8519	E	
Solar return temp	8520	E	
24-hour yield solar energy	8526	Eu	
Total yield solar energy	8527	Eu	
Hours run solar yield	8530	Eu	
Hours run collect overtemp	8531	E	
Hours run collector pump	8532	Eu	
Solid fuel boiler temp	8560	C	
Hours run solid fuel boiler	8570	C	

Diagnostics consumers	Prog. no.	Level	Standard value
Outside temp	8700	Eu	
Outside temp min	8701	Eu	
Outside temp max	8702	Eu	
Outside temp attenuated	8703	E	
Outside temp composite	8704	E	
Heating circuit pump 1 Off On	8730	C	
Heat circ mix valve 1 open Off On	8731	C	
Heat circ mix valve 1 close Off On	8732	C	
Speed heating circuit pump 1	8735	C	
Room temp 1 • Room setpoint 1	8740	C	
Flow temp 1 • Flow temp setpoint 1	8743	C	
Room thermostat 1 0: No demand 1: Demand	8749	C	
Heating circuit pump 2 Off On	8760	C	
Heat circ mix valve 2 open Off On	8761	C	
Heat circ mix valve 2 close Off On	8762	C	
Speed heating circuit pump 2	8765	C	
Room temp 2 • Room setpoint 2	8770	C	
Flow temp 2 • Flow temp setpoint 2	8773	C	
Room thermostat 2 0: No demand 1: Demand	8779	C	
Heating circuit pump 3 Off On	8790	C	
HC mixing valve 3 open Off On	8791	C	
HC mixing valve 3 closed Off On	8792	C	
Speed heating circuit pump 3	8795	C	
Room temp 3 • Room setpoint 3	8800	C	

Diagnosics consumers	Prog. no.	Level	Standard value
Flow temp 3 • Flow temp setpoint 3	8804	C	
Room thermostat 3 0: No demand 1: Demand	8809	C	
DHW pump Off On	8820	C	
DHW interm circ pump Q33 Off On	8823	E	
Speed DHW pump	8825	E	
Speed DHW interm circ pump	8826	E	
DHW temp 1 • DHW temp setpoint	8830	C	
DHW temp 2	8832	C	
DHW circulation temp	8835	E	
DHW charging temp	8836	E	
Flow temp setp VK1	8875	C	
Flow temp setp VK2	8885	C	
Flow temp setp VK3	8895	C	
Swimming pool temp • Swimming pool setpoint	8900	C	
Primary controller temp • Primary controller setpoint	8930	E	
Common flow temp • Common flow temp setpoint	8950	E	
Common return temp	8952	E	
Common output setpoint	8962	E	
Buffer temp 1	8980	C	
Buffer setpoint	8981	C	
Buffer temp 2	8982	C	
Buffer temp 3	8983	C	
Water pressure H3	9009	E	
Relay output QX1 Off On	9031	C	
Relay output QX2 Off On	9032	C	
Relay output QX3 Off On	9033	C	
Relay output QX21 module 1 Off On	9050	C	
Relay output QX22 module 1 Off On	9051	C	
Relay output QX23 module 1 Off On	9052	C	
Relay output QX21 module 2 Off On	9053	C	
Relay output QX22 module 2 Off On	9054	C	
Relay output QX23 module 2 Off On	9055	C	

Burner control	Prog. no.	Level	Standard value
Prepurge time	9500	E	15 s
Required output prepurging ⁽¹⁾	9504	E	Paramount 30: 14,5 kW; Paramount 40: 19.5 kW Paramount 50: kW; Paramount 60: 35,0 kW; Paramount 80: 50,0 kW; Paramount 95: 50,8 kW; Paramount 115: 56.6 kW
Required output ignition ¹⁾	9512	E	Paramount 30: 14,5 kW; Paramount 40: 19.5 kW Paramount 50: kW; Paramount 60: 35,0 kW; Paramount 80: 50,0 kW; Paramount 95: 50,8 kW; Paramount 115: 56.6 kW
Required output LF ¹⁾	9524	E	Paramount 30: 5,6 kW; Paramount 40: 9.0 kW Paramount 50: 10,0 kW; Paramount 60: 14,0 kW; Paramount 80: 21,0 kW; Paramount 95: 20,0 kW; Paramount 115: 25.0 kW
Required output HF ¹⁾	9529	E	Paramount 30: 30,0 kW; Paramount 40: 38.0 kW Paramount 50: 50,0 kW; Paramount 60: 58,0 kW; Paramount 80: 77,0 kW; Paramount 95: 95,0 kW; Paramount 115: 115,0 kW
Postpurge time	9540	E	10 s
Fan output/speed slope	9626	E	Paramount 30: 214,3; Paramount 40: 150.0 Paramount 50: 111,3; Paramount 60: 98,9; Paramount 80: 69,6; Paramount 95: 63,1; Paramount 115: 57,0
Fan output/speed Y-section	9627	E	Paramount 30: 100,0; Paramount 40: 100.0 Paramount 50: 138,0; Paramount 60: 70,0; Paramount 80: 240,0; Paramount 95: 320,0; Paramount 115: 300,0
(1) the kW settings are approximate values. Exact values can be determined by the gas meter for example.			

Info option ⁽¹⁾	Prog. no.	Level	Standard value
Error/alarm message			
Maintenance			
Setpoint manual control			

Info option ⁽¹⁾	Prog. no.	Level	Standard value
304:Controller stop			
Boiler temp			
Outside temp			
Domestic water temperature			
Collector temp B6			
24-hour yield solar energy			
Total yield solar energy			
Solid fuel boiler temp			
Buffer temperature			
Swimming pool temp			
State heating circuit 1			
State heating circuit 2			
State heating circuit 3			
State DHW			
State boiler			
State solar			
State solid fuel boiler			
State buffer			
State swimming pool			
Year			
Date			
Time			
Telephone customer service			
Water pressure			
(1) The display of the information values depends on the operating Status!			

9.2 Description of the parameters

9.2.1 Time and date

■ Time and date (1–3)

The regulator has a year clock with setting possibilities for time, day/month and year. Time and date must be correctly set, so that the heating programs can operate to previously carried out programming.

■ Summer time (5/6)

The start of summer time can be set under prog. no. 5; the end of summer time is set under prog. no. 6. The time changing is carried out on the Sunday following the set date.

9.2.2 Operator section

■ Language (20)

This is where you can change the language of the users prompts.

■ Info (22)

- Temporarily: The information display returns to the basic display after 8 minutes.
- Permanently: The information display remains permanently displayed after call-up with the information button.

■ Display of errors (23)

Program no. 23 can be used to select whether errors are displayed showing just the error code ("Code" option) or the error code with text ("Code and text" option).

■ Contrast of display (25)

You can select the contrast of the display here.

■ Operation lock (26)

If this function is activated the following operating elements are locked:

- Operating mode buttons for heating and drinking water mode
- Rotary selector (room temperature comfort setpoint)
- Presence button (only room unit)

■ Programming lock (27)

If this lock is activated, parameters can be displayed but not changed.

- Temporary unlocking:
Press OK and ESC simultaneously for at least 3 s. The lock will be re-activated after leaving the setting level.
- Permanent unlocking:
First temporary unlocking, then prog.no. 27 to Off.

■ Units (29)

Here you can choose between SI units (°C, bar) and US-American units (°F, PSI).

■ Save basic settings (30)

The parameters of the regulator are written into the room unit/backed up (only available for room unit).



Caution

The parameters of the room unit are overwritten! With this, the individual programming of the regulator in the room unit can be ensured.

■ Activate basic settings (31)

The data of the operating unit or room unit are written into the control.



Caution

The control parameters are overwritten. The factory settings are stored in the operating unit.

- Activation of prog. no. 31 at the *operating unit*.
The regulator is reset to **factory setting**.
- Activation of prog. no. 31 at the *room unit*.
The individual programming of the room unit is written into the control.



Important

This parameter is only visible if a suitable standard setting is available in the programming unit.

■ Used as (40)

- Room unit 1/Room unit 2/Room unit 3: this setting establishes which heating circuit the room unit on which this setting is made is to be used. When Room unit 1 is selected, further heating circuits can be assigned under prog.no. 42, whereas when Room unit 2/Room unit 3 is selected only the relevant heating circuit can be operated.
- Operator unit 1/Operator unit 2/Operator unit 3: this setting is provided for pure operation without room functions and is not required in connection with this controller.
- Service unit: this setting is used, for example, to back up or save controller settings.

■ Assignment device 1 (42)

If setting Room unit 1 (prog. no. 40) was selected at the room controller, determine the heating circuits to which room controller 1 is assigned under prog. no. 42.

■ Operation HC2/Operation HC3/P (44/46)

When Room unit 1 or Operator unit 1 (prog.no. 40) is selected, it must be defined under prog.no. 44 or 46 whether the heating circuits HK2 and HK3/P are to be operated together with heating circuit 1 or independently of heating circuit 1.

■ Room temperature device 1 (47)

The assignment of room unit 1 to the heating circuits can be selected here.

- Heating circuit 1 only: The room temperature is sent exclusively to heating circuit 1.
- For all assigned HCs: The room temperature is sent to the heating circuits assigned under prog. no. 42.

■ Action occupancy button (48)

You can select the assignment of the presence key here.

- None: Pressing the presence key has no effect on the heating circuits.
- Heating circuit 1 only: The presence key only affects heating circuit 1.
- For all assigned HCs: The presence key affects the heating circuits assigned under prog. no. 42.

■ Readjustment room sensor (54)

The temperature display of the value transmitted by the room sensor can be corrected here.

■ Software version (70)

Display of the current software version.

9.2.3 Wireless

■ Device list (130-138)

The state of the respective device will be displayed under programme numbers 130 to 138.

■ Delete all devices (140)

The wireless connections to all units is cancelled here.

9.2.4 Time programs

■ General information about the time programs.



Important

Time programs 1 and 2 are always assigned to the respective heating circuits (1 and 2) and only displayed if these heating circuits are present and also turned on in the menu **Configuration** (prog.-no. 5710 and 5715).

Time program 3 can be used for heating circuit 3, for the DHW and for the circulation pump, depending on the setting, and is always displayed.

Time program 4 can be used for the DHW and for the circulation pump, depending on the setting, and is always displayed.

Time program 5 is not assigned a function and can be freely used for any application using an output QX.

■ Preselection (500 – 600)

Selection of weekday or day blocks. The day blocks (Mon-Sun, Mon-Fri and Sat-Sun) assist the adjustment. The set times are only copied to the individual weekdays and can be changed in the individual day settings as required.

The times of the individual weekdays always determine the heating program.

**Important**

If a time in a group of days is changed, all 3 start/stop phases will be copied to the day group automatically.

To select groups of days (Mon-Sun, Mon-Fri or Sat-Sun), turn the control knob anti-clockwise; to select individual days (Mon, Tue, Wed, Thu, Fri, Sat, Sun), turn the control knob clockwise.

■ Heating phases (501 — 606)

Up to 3 heating phases can be set per heating circuit. These are active on the days selected under Preselection (prog.no. 500, 520, 540, 560, 600). During the heating phases the system heats to the set comfort setpoint. Outside the heating phases, the system heats to the reduced setpoint.

**Important**

The time programs are only activated in Automatically operating mode.

■ Copy? (515–615)

The time program for one day can be copied and assigned to another or several other days.

**Important**

Day blocks cannot be copied.

■ Default values (516–616)

Setting of the default values given in the setting table

9.2.5 Holiday programs

■ Preselection (641 - 661)

**Important**

The heating circuits may be set to a selectable operation level with the holiday programme during a certain holiday period.

8 holiday periods can be selected with this preselection.

■ Start of holiday (642 - 662)

Entering the holiday start.

■ End of holiday (643 - 663)

Entering the holiday end.

■ Operating level (648-668)

Selection of the operating level (Reduced or Protection) for the holiday programme

**Important**

A holiday period always ends on the last day at 12:00 AM (23:59). The holiday programmes are only activated in the operation mode Automatically.

**See**

See also the User manual Paramount.

9.2.6 Heating circuits

■ Operating mode (700, 1000, 1300)

The operating mode can be set via the operation mode button at the boiler or at the room device. For other service tools, the operating mode is set via this control line.

- Protection: The heating is switched off in protection mode. The room remains protected against frost however (Frost protection setpoint, e.g. prog. no. 714).

- Automatic: In automatic mode, the room temperature is controlled in accordance with the time program that is selected.
- Reduced: In reduced operation mode the room temperature is kept constantly to the set Reduced setpoint(e.g. prog. no. 712).
- Comfort: In comfort mode the room temperature is kept constantly to the set Comfort setpoint(e.g. prog. no. 710). Eco functions are not activated.

■ **Comfort setpoint (710, 1010, 1310)**

Setting of the comfort setpoint in the heating phases. Without room sensor or with the room influence switched off (prog.no. 750, 1050, 1350), this value is used for calculation of the flow temperature, to theoretically reach the set room temperature.

■ **Reduced setpoint (712, 1012, 1312)**

Setting of the desired room temperature during the reduced heating phase. Without room sensor or with the room influence switched off (prog.no. 750, 1050, 1350), this value is used for calculation of the flow temperature, to theoretically reach the set room temperature.

■ **Frost protection setpoint (714, 1014, 1314)**

Setting of the required room temperature during frost protection mode. Without room sensor or with the Room influence(prog.no. 750, 1050, 1350), this value is used for calculation of the flow temperature, to theoretically reach the set room The heating circuit remains turned off until the flow temperature drops so far that the room temperature falls below the frost protection temperature.

■ **Heating curve slope (720, 1020, 1320)**

Using the heating curve, the flow temperature setpoint is formed that is used to regulate the heating circuit, subject to the outside temperature. The gradient indicates how much the flow temperature changes by with changing outside temperature.

Fig.20 Heating curve diagram

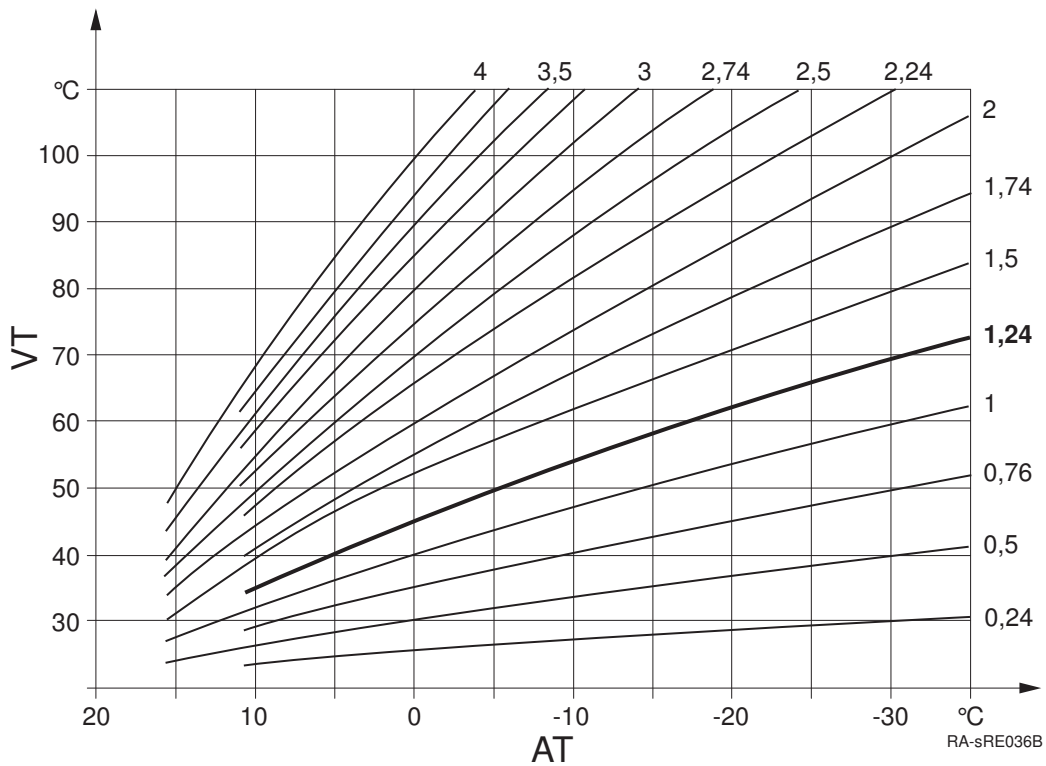

AT Outdoor temperature

VT Flow temperature

Determination of the heating curve gradient

Enter the lowest calculated outside temperature in accordance with the climate zone (e.g. -12 °C in Frankfurt) into the diagram (see fig.) (e.g. vertical line at -12°C). Enter the maximum flow temperature of the heating circuit, which is reached by calculating with -12 °C outside temperature at 20 °C room temperature (e.g. horizontal line at approx. 55 °C).

The intersection of both lines provides the value for the heating curve gradient.

■ Heating curve displacement (721, 1021, 1321)

Heating curve correction by parallel offset if the room temperature is generally too high or too low.

■ Heating curve adaption (726, 1026, 1326)

Automatic adaptation of the heating curve to the actual conditions, as a result of which no correction of the heating curve slope is required.

i Important

Automatic adaptation of the heating curve requires the connection of a room sensor. The value for Room influence (see prog. no. 750, 1050, 1350) must be set between 1% and 99%. Should there be radiator valves in the lead room (where the room sensor is installed), these must be fully opened.

■ Summer/winter heating limit (730, 1030, 1330)

Fig.21 Summer/winter heating limit

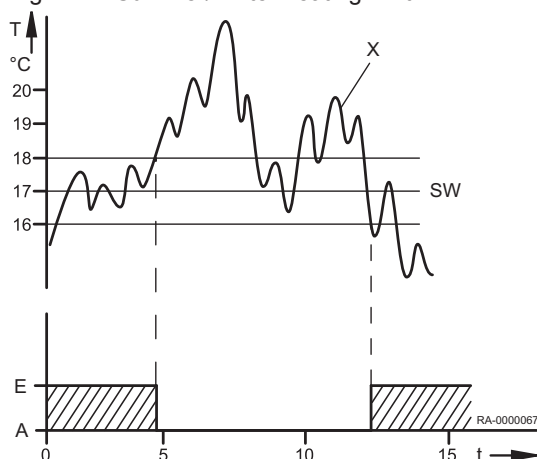

- A Off
- E On
- SW Summer/winter heating limit
- T Temperature
- t Time
- x Outside temp attenuated (prog.no. 8703)

The heating circuit switches to summer operation as soon as the average outside temperature over the past 24 hours rises 1°C above the value set here. As soon as the average of the outside temperatures of the last 24 hours drops 1°C below the value set here, the heating circuit switches back into winter mode.

■ 24-hour heating limit (732, 1032, 1332)

The 24-hour heating limit shuts off the heating circuit if the current outside temperature increases up to the differential set here to the current operating level (reduced or comfort setpoint). The heating switches on again if the current outside temperature falls again below the set differential minus 1 °C.

i Important

In the operating mode **continuous mode** ☀ or ☾ this function is not activated.

■ Flow temp setpoint min (740, 1040, 1340) and Flow temp setpoint max (741, 1041, 1341)

With this function, a range can be defined for the flow setpoint. When the flow temperature setpoint reaches the respective limit, this remains constant, even if heat demand rises or falls.

If a pump heating circuit is operated parallel with other requirements, it can cause higher resulting temperatures in the pump heating circuit.

■ Flow temp setpoint room stat (742, 1042, 1342)

For room thermostat mode the flow setpoint set here applies.

With the setting $-\text{°C}$, the value calculated via the heating curve is used as the flow setpoint.

■ **Swi-on ratio room stat (744, 1044, 1344)**

The boiler tries to adapt the flow temperature so that the switch-on ratio set under this parameter is achieved by the ambient thermostats

■ **Delay heat request (746, 1046, 1346)**

The boiler heat request is forwarded to the burner delayed by the time set here. In this way a slowly opening mixer can already start up before the burner goes into operation.



Important

If the option Absolute is selected under prog.no. 1630, the value 0 must be set under this prog.no. For special functions (e.g. chimney-sweep function) the delay does not have an effect (see prog.no. 2470).



For more information, see

Charging priority (1630), page 95
 Delay heat req special op (2470), page 102

■ **Room influence (750, 1050, 1350)**

The flow temperature is calculated by means of the heating curve subject to outside temperature. This type of control assumes that the heating curve is set correctly, since room temperature is not taken into consideration with this setting.



Important

However, if there is a room unit (e.g. RGP) is connected and the setting "room influence" is set between 1 and 99%, the deviation of the room temperature compared to the set point is recorded and taken into consideration in the temperature control. In this way any external heat can be taken into account enabling a constant room temperature to be achieved. The influence of the deviation can be set in percentage. The more representative the lead room is (correct room temperature, correct installation location etc.), the higher the value can be set, giving the room temperature even greater relevance.



Caution

Should there be radiator valves in the lead room (where the room sensor is installed), they must be opened fully.

- Setting for weather compensation with room influence: 1% - 99%
- Setting for pure weather compensation: $-\text{---}\%$
- Setting for pure room compensation: 100%

■ **Room temp limitation (760, 1060, 1360)**

- TRx** Room temperature actual value
- TRw** Room temperature setpoint
- SDR** Room switching difference
- P** Pump
- t** Time
- 1** On
- 0** Off

The heating circuit pump is switched on or off subject to room temperature in line with the switching differential set here. The switch-off point of the pump is set as the difference to the set room setpoint. The pump switch-on point is 0.25 °C below the room setpoint. This function is only possible with a room device (e.g. RGP) and active room influence.



Important

A room sensor must be connected. This function only applies to pumped heating circuits.

Fig.22 Room temp limitation

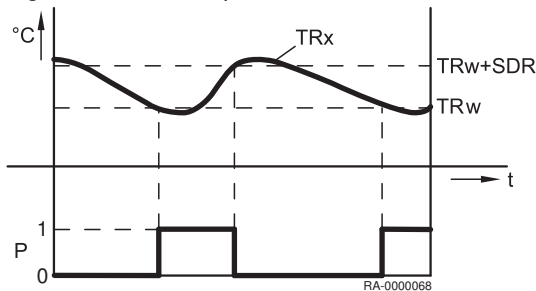

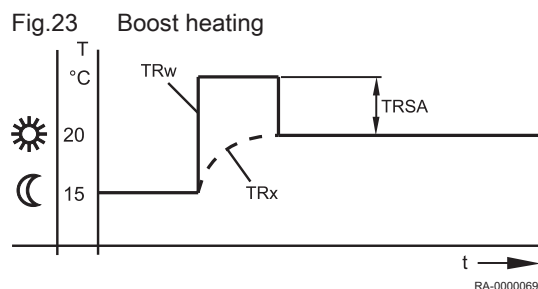

■ Boost heating (770, 1070, 1370)

- TR_w** Room temperature setpoint
- TR_x** Room temperature actual value
- TRSA** Room temperature setpoint-raised

The boost heating becomes active when the room temperature setpoint is switched over from protection or reduced mode to comfort mode. During the boost heating, the room temperature setpoint is increased by the value set here. This causes the actual room temperature to rise to the new temperature setpoint quickly.

Without room sensor or without room influence, boost heating is implemented in accordance with an internal calculation. Due to the room setpoint acting as a basis, the effect of the duration of the boost heating and that of the flow temperature works differently for each outside temperature.

■ Quick setback (780, 1080, 1380)

Quick reduction becomes active if the room temperature setpoint is switched from comfort level to another operating level (reduced mode or protection mode). During quick reduction the heating circuit pump is switched off and the mixing valve is also closed in the case of mixed circuits. During quick reduction no heat requirement is sent to the heat generator.

Quick reduction is possible with or without room sensor: with room sensor the heating circle function is switched off until the room temperature has dropped to the reduced setpoint or frost protection setpoint. When the room temperature has dropped to the reduced setpoint or the frost protection setpoint, the heating circuit pump starts again and the mixing valve is enabled. Without room sensor the quick reduction switches the heater off depending on the outside temperature and the building time constant (prog.no. 6110) until the temperature has theoretically dropped to the reduced target value or the frost protection value.

Tab.21 Duration of the quick reduction

Duration of the quick reduction for reduction by 2°C in hrs:							
Outside temperature mixed:	Building time constant (configuration, prog.no. 6110)						
	0 hrs	2 hrs	5 hrs	10 hrs	15 hrs	20 hrs	50 hrs
15°C	0	3.1	7.7	15.3	23		
10°C	0	1.3	3.3	6.7	10	13.4	
5°C	0	0.9	2.1	4.3	6.4	8.6	21.5
0°C	0	0.6	1.6	3.2	4.7	6.3	15.8
-5°C	0	0.5	1.3	2.5	3.8	5	12.5
-10°C	0	0.4	1	2.1	3.1	4.1	10.3
-15°C	0	0.4	0.9	1.8	2.6	3.5	8.8
-20°C	0	0.3	0.8	1.5	2.3	3.1	7.7
Duration of the quick reduction for reduction by 4°C in hrs:							
Outside temperature mixed:	Building time constant (configuration, prog.no. 6110)						
	0 hrs	2 hrs	5 hrs	10 hrs	15 hrs	20 hrs	50 hrs
15°C	0	9.7	24.1				
10°C	0	3.1	7.7	15.3	23		
5°C	0	1.9	4.7	9.3	14	18.6	
0°C	0	1.3	3.3	6.7	10	13.4	
-5°C	0	1	2.6	5.2	7.8	10.5	26,2
-10°C	0	0.9	2.1	4.3	6.4	8.6	21.5
-15°C	0	0.7	1.8	3.6	5.5	7.3	18.2
-20°C	0	0.6	1.6	3.2	4.7	6.3	15.8



For more information, see
Time constant building (6110), page 121

■ **Optimum start control max (790, 1090, 1390) and Optimum stop control max (791, 1091, 1391)**

Fig.24 Optimum start and stop control

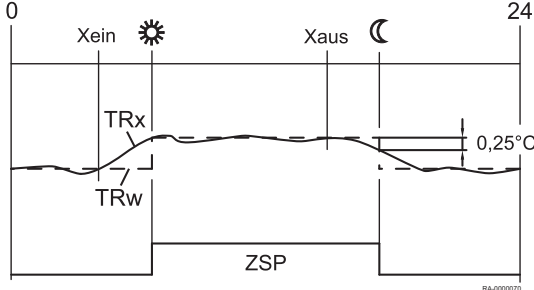

- Xon** Start time set forward
- Xoff** Stop time set forward
- ZSP** Time program
- TRw** Room temperature setpoint
- TRx** Room temperature actual value

The optimisation of the on/off switching times is a function of time and possible with or without room unit. With a room unit the changeover of operating level compared to the programmed time moves forward so that the building dynamics (heat-up and cool-down times) are taken into account. In this way the required temperature level is reached exactly at the programmed time. If this is not the case (too early or too late) a new switching time is calculated that is applied next time.

Without room sensor an advance time is calculated based on the outside temperature and the building time constant (prog. no. 6110). The optimisation time (advance) is limited here to a maximum value. By setting the optimisation time = 0, the function is switched off.



For more information, see
Time constant building (6110), page 121

■ **Reduced setp increase start (800, 1090, 1390) and Reduced setp increase end (801, 1101, 1401)**

Fig.25 Reduced setpoint increase

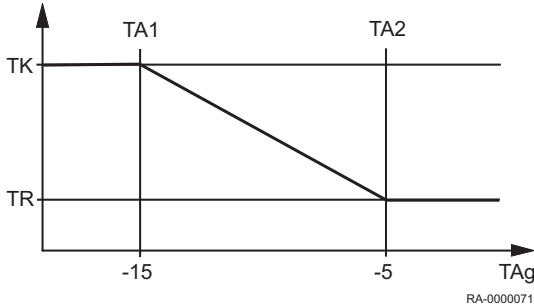

- TA1** Reduced setpoint increase start
- TA2** Reduced setpoint increase end
- TK** Comfort setpoint
- TR** Room temperature reduced setpoint
- TAg** Outside temperature mixed

When only a small heating output is required to cover demand, the reduced room setpoint can be increased in the case of cold outside temperatures. This increase is subject to outside temperature. The lower the outside temperature, the higher the reduced room temperature setpoint will be increased. The start and end of the increase can be selected. Between these two points there is a linear increase of the "reduced setpoint" up to the "comfort setpoint".

■ **Continuous pump operation (809, 1109, 1409)**

This function is used to suppress the pump switching off during the quick reduction and when the room setpoint is reached (room thermostat, room sensor or room model).

- No: the heating circuit pump /boiler pump can be switched off by quick reduction or reaching the room set point.
- Yes: the heating circuit pump/boiler pump remains switched on even during the quick reduction and after the room setpoint has been reached.

■ **Overtemp prot pump circuit (820, 1120, 1420)**

This function prevents overheating of the pump heating circuit by switching the pump on and off, if the flow temperature is higher than the flow temperature required according to the heating curve (e.g. in case of higher requests from other consumers).

■ Mixing valve boost (830, 1130, 1430)

The heat request of the mixed heating circuit to the heat source is raised above the value set here. This boost is intended to correct temperature fluctuations to be able to be compensated with the mixer controller.

■ Actuator running time (834, 941, 1134)

Setting the actuator running time of the mixing valve used.

For mixing circuits, a kick-start of the mixer drive is carried out after a pump kick-start (pump is OFF). In this case, the mixer is controlled in direction OPEN and CLOSED.

The time of activation in direction OPEN corresponds to the drive running time.

■ Floor curing function (850, 1150, 1450)

- X Start day
- Fh Functional heating
- Ch Curing heating

The floor curing function serves controlled drying out of screed floors

- Off: The function is switched off.
- Functional heating: Part 1 of the temperature profile is run automatically.
- Curing heating: Part 2 of the temperature profile is run automatically.
- Functional/curing heating: The whole temperature profile is run automatically.
- Manually: Manual control to the screed setpoint.

Fig.26 Temperature profile of the floor curing function

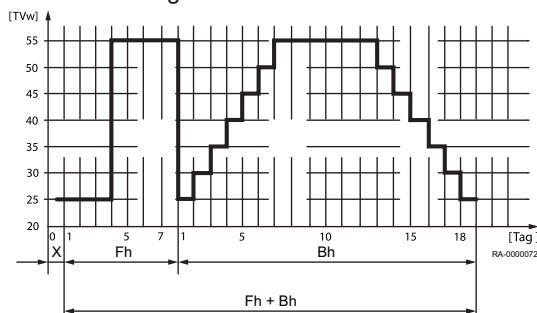

Caution
Observe the requirements and standards issued by the screed manufacturer.

A correct function is only possible with a correctly installed heating system (hydraulic, electrical systems and settings).

Deviations can result in damage to the screed.

The screed function can be stopped prematurely by setting **0=OFF**.

■ Floor curing setp manually (851, 1151, 1451)

Setting of the temperature to which manual control is carried out with floor curing function activated.

 **For more information, see**
Floor curing function (850, 1150, 1450), page 93

■ Floor curing setp current (855, 1155, 1455)

Display of the current floor curing setpoint.

■ Days completed.current (856, 1156, 1456)

Display of the current floor curing function day.

■ Excess heat draw (861, 1161, 1461)

If the excess temperature draw is activated via input H1 to H5 or a maximum temperature is exceeded in the system, this excess heat energy can be released by a heat draw of the room heating.

- Off: The function is switched off.
- Heating mode: The function is only limited to one draw-off during the heating times.
- Always: The function is generally released.

■ With buffer (870, 1170, 1470)

This parameter establishes whether the heating circuit can be supplied by a buffer or storage tank or only by a heat generator. The function also determines whether the system pump goes into operation when a heat demand is submitted.

- No: The heating circuit is supplied from the boiler.

- Yes: The heating circuit can be supplied from the buffer storage tank.

■ With prim contr/system pump (872, 1172, 1472, 5092)

This parameter establishes whether a zone system pump goes into operation with a heat demand of the heating circuit. This system pump is based on the segment in which this controller is located (LPB bus system) and which is controlled with a primary control.

- No: The heating circuit is supplied without primary controller/system pump.
- Yes: The heating circuit is supplied from the primary controller by the system pump.

■ Pump speed reduction (880, 1180, 1480)

Speed regulation of the heating circuit pump can be done according to *operating level* or *pump curve*.

- *Operating level*: With this option the speed of the heating circuit pump is actuated according to the operating level. The pump is controlled in operating level *Comfort* (incl. optimization) or during active floor curing function at maximum speed. With reduced operating level the pump is controlled with the parameterized minimum speed.
- *Characteristic*: With the weather-compensated control variant (with or without ambient temperature compensation), the speed of the heating circuit pump will be kept at the minimum speed for as long as it remains possible to meet the heat demand. In order to enable the heat demand to be met at reduced speed, the heating curve is increased. This flow increase is parametrizable. This setting defines the flow increase in percent at minimum heating circuit pump speed. The speed is only increased when the maximum permitted flow setpoint is reached.
- Temp differential nominal: The spread between boiler flow temperature and boiler return temperature is called the temperature rise.



Important

Since regulation is via the boiler sensor, this setting is only suitable if one pump heating circuit is available.

■ Pump speed min (882, 1182, 1482)

The minimum speed for the heating circuit pump can be specified using this function.

■ Pump speed max (883, 1183, 1483)

The maximum speed for the heating circuit pump can be specified using this function.

■ Curve readj at 50% speed (888, 1188, 1488)

Correction of the flow setpoint with reduction of the pump speed by 50%. The correction is calculated using the difference from the flow setpoint according to the heating curve and current room setpoint.

■ Flow setp readj speed ctrl (890, 1190, 1490)

Here it can be specified whether the calculated flow setpoint correction is included in the temperature request or not.

- No: The temperature request remains unchanged. The calculated correction value is not added.
- Yes: The temperature request includes the flow setpoint correction.

■ Operating level changeover (898, 1198, 1498)

When an external timer is used above the inputs *Hx* selection of the operating level to which the heating circuits are to be switched is possible.

- Protection
- Reduced
- Comfort

■ Optg mode changeover (900, 1200, 1500)

With external change of operating mode via Hx it can be selected whether during automatic operation it is changed from comfort set point to the frost prevention setpoint or reduced setpoint.

9.2.7 Domestic water

■ DHW

The Paramount controls the domestic water temperature in accordance with the time program or continuously to the setpoint required in each case. The priority of the domestic water charging relative to the room heating can be set here. The controller has an adjustable Legionella function, which prevents Legionella in the storage tank and in the circulation line. The circulation pump is regulated to the required setpoint in accordance with the selectable time program and operating mode.

■ Nominal setpoint (1610)

Setting the drinking water nominal value

■ Reduced setpoint (1612)

Setting the DHW reduced setpoint.

■ Nominal setpoint max (1614)

Set the maximum permissible DHW nominal value.

■ Release (1620)

- 24h/day: The DHW temperature will be continuously controlled to the nominal drinking water temperature value independent from the time programmes.
- Time programs HCs: The DHW temperature will be switched over between the nominal DHW temperature value and the reduced nominal DHW temperature value depending on the time programs. Every time, the switching-on time is moved forward.
 - It is moved forward by 1 hour.

Fig.27 Release depending on the time programmes of the heating circuits (example)

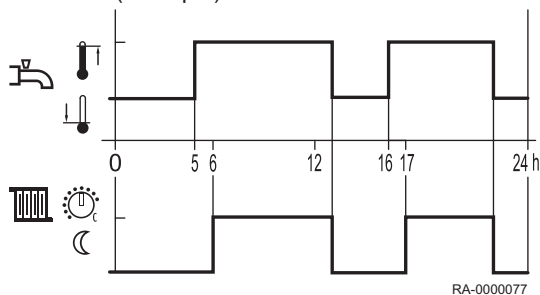
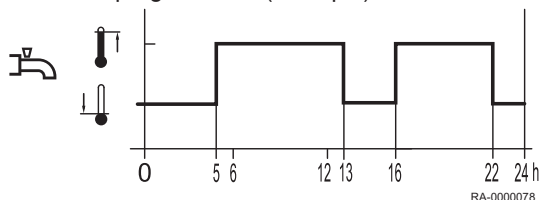

Fig.28 Release according to time programme 4 (example)



Time program 4/DHW: The DHW temperature is changed over between the DHW temperature setpoint and the reduced DHW temperature setpoint independently of time programs of the heating circuit. For this, time program 4 is used.

■ Charging priority (1630)

This function ensures that the boiler capacity is primarily made available for DHW in case of simultaneous capacity demand by room heating and DHW.

- Absolute: Mixer and pumped heating circuits are blocked until the DHW has been heated up.
- Shifting: Should the boiler capacity not be sufficient to heat up DHW, mixer and pumped heating circuits will be restricted.
- None: Charging DHW is carried out in parallel with heating operation.

- MC shifting, PC absolute: Pumped heating circuits are blocked until the DHW has been heated up. Should the boiler capacity not be sufficient, the mixer circuit will also be restricted.



For more information, see

Delay heat request (746, 1046, 1346), page 90

■ Legionella function (1640)

Function to kill legionella germs by heating up to the set legionella function setpoint (see programme number 1645).

- Off: Legionella function is switched off.
- Periodically: Legionella function is repeated periodically, depending on the set value (prog. no. 1641).
- Fixed weekday: Legionella function will be activated on a certain weekday (prog. no. 1642).

■ Legionella funct periodically (1641)

Setting the interval for the legionella function periodically (recommended setting in case of additional drinking water heating by solar plant in connection with a storage tank mixing pump).

■ Legionella funct weekday (1642)

Selection of the weekday for the legionella function.

■ Legionella funct time (1644)

Setting the start time for the legionella function. With setting — the legionella function will be carried out the first time DHW heating is enabled.

■ Legionella funct setpoint (1645)

Selecting the set temperature required for killing the bacteria.

■ Legionella funct duration (1646)

With this function, the time is set during which the legionella function setpoint is activated to kill germs.



Important

If the colder storage tank temperature rises to above the **legionella function setpoint** -1 K, the **legionella function setpoint** is considered as met and the timer starts running. If the storage tank temperature drops by more than the switching difference +2K below the required **legionella function setpoint**, the duration has to be met again. If no duration has been set, the legionella function is met immediately when the **legionella function setpoint** is reached.

■ Legionella funct circ pump (1647)

- On: The circulation pump will be switched on in case of active legionella function.



Warning

When legionella function is active, there is a risk of scalding at the draw-off points.

■ Circulating pump release (1660)

- Time program 3/HC3: The circulating pump is released subject to time program 3 (see prog. no. 540 to 556).
- DHW release: The circulating pump is released when DHW heating is released.
- Time program 4/DHW: The circulating pump is released subject to time program 4.
- Time program 5: The circulating pump is released subject to time program 5.

■ Circulating pump cycling (1661)

To save energy, the circulation pump is switched on for 10 minutes and off for 20 minutes within the release time.

■ Circulation setpoint (1663)

If sensor B39 is placed in the domestic water distribution line, circulation pump Q4 is switched on as soon as the sensor value falls below the set value. The pump then runs at a fixed rate for 10 minutes or longer until the setpoint has been reached again. There is always a fixed difference of 8 K between the setpoint for the domestic water storage tank and the setpoint for sensor B39 (program no. 1663). This is intended to ensure that the circulation setpoint can also be reached and the circulation pump does not run indefinitely.

Example 1

- DHW setpoint: 55 °C (nominal setpoint)
- Circulation setpoint: 45 °C

→ The circulation pump switches on if the sensor value falls below 45 °C, and runs for at least 10 minutes.

Example 2

- DHW setpoint: 50 °C (nominal setpoint)
- Circulation setpoint: 45 °C

→ The circulation pump switches on if the sensor value falls below 42 °C (50 °C - 8 °C), and runs for at least 10 minutes.

■ Optg mode changeover (1680)

Using external switching above the entrance H1 it can be selected into which operating mode is switched into.

- *None*: The external changeover does not affect the DHW operating mode.
- *Off*: DHW is switched to the operating mode "Off".
- *On*: DHW is switched to the operating mode "On".

9.2.8 Consumer circuits/swimming pool circuit

■ Consumer circuits/swimming pool circuit

In addition to the heating circuits HK1 to HK3 and the cooling circuit, additional consumers can be connected or controlled (e.g. air curtains, swimming pools, etc.). The controller can receive the temperature requests of these consumers via an Hx input and control the corresponding pumps via a QX relay output. Various settings are available for the consumer circuit. An appropriately defined Hx input on the device or on an expansion module (program no. 5950, 5960 or 6046, 6054, 6062) is required for use of the consumer circuit/swimming pool circuit. The input can be defined as follows:

- Consumer request VK1
- Consumer request VK2
- Consumer request VK1 10V
- Consumer request VK2 10V
- Release swi pool source heat

The pumps are connected at the appropriately defined multifunctional Qx relay outputs. The consumer circuit pumps (Q15/Q18) are put into operation if there is a heat or cooling demand at the corresponding input or an excess temperature discharge is requested by the system. The swimming pool circuit (Q19) is put into operation if there is a release at the appropriate input and the swimming pool temperature (B13) is below the "Setpoint source heating" (program no. 2056).

■ Flow temp setp cons request (1859, 1909, 1959)

Setting of the flow setpoint is done with this function, which is effective during active request of the consumer circuit.

■ **DHW charging priority (1874, 1924, 1974)**

Setting as to whether domestic hot water charging takes priority over the consumer circuit/swimming pool circuit or not.

■ **Excess heat draw (1875, 1925, 1975)**

If an excess temperature discharge is activated, the excess energy can be discharged heat being drawn by the consumer circuits. This can be set separately for each consumer circuit.

■ **With buffer (1878, 1928, 1978)**

This parameter establishes whether the heating circuit can be supplied by a buffer or storage tank or only by a heat generator. The function also determines whether the system pump goes into operation when a heat demand is submitted.

- No: The heating circuit is supplied from the boiler.
- Yes: The heating circuit can be supplied from the buffer storage tank.

■ **With prim contr/system pump (1880, 1930, 1980)**

- No: The consumer circuit is supplied without primary control unit/system pump
- Yes: The consumer circuit is supplied from the primary controller on/by the system pump.

9.2.9 Swimming pool

■ **Swimming pool**

The controller enables a swimming pool to be heated with solar energy or via heat generators, each with a separately adjustable setpoint. For solar heating, the priority of the swimming pool heating relative to the storage tank charging can be set.

■ **Setpoint solar heating (2055)**

When solar energy is used, the swimming pool is heated to the setpoint set here.

■ **Setpoint source heating (2056)**

When using the generator heating, the swimming pool is heated to the setpoint set here.

■ **Charging priority solar (2065)**

Setting of which priority the swimming pool will be solar heated. The priority for the DHW and charging buffer is set under Prog. no. 3822.

- Priority 1: Charging the swimming pool has top priority.
- Priority 2: Charging the swimming pool has middle priority (between the domestic water and the buffer storage tank).
- Priority 3: Charging the swimming pool has lowest priority (after the domestic water and the buffer storage tank).



Important

Release and priority can also be affected by the Hx inputs (see also program no. 3822).



For more information, see

Charging prio storage tank (3822), page 105

■ **Swimming pool temp max (2070)**

If the swimming pool temp reaches the heating limit set here, the collector pump is switched off. It is again released if the swimming pool temp has dropped by 1°C below the maximum heating limit temperature.

■ **With solar integration (2080)**

Setting, of whether the swimming pool heating can be done by solar energy or not.

9.2.10 Primary control/feed pump

■ Primary contr/system pump

The primary controller enables the flow temperature to be mixed up or down for heatinggroups with flow temperature setpoints that are lower or higher than the temperature present on the rail. The feed pump can overcome the pressure drop to heatinggroups that are further away.

■ Flow temp setpoint min (2110) and Flow temp setpoint max (2111)

With these boundaries a range for the flow setpoint can be defined.

■ Syst pump on heat gen lock (2121)

This parameter can set whether the system pump is also locked or not when the generator lock is active.

- Off: The system pump is not locked.
- On: When the generator lock is active the system pump is also locked.

■ Mixing valve boost (2130)

For the admixture the boiler flow temperature actual value must be higher than the requested setpoint of the mixer flow temperature, since this cannot be corrected otherwise. The controller forms the boiler temperature setpoint from the boost set here and the current flow temperature setpoint.

■ Actuator running time (2134)

Setting the actuator running time of the mixing valve used.

■ Primary contr/system pump (2150)

- Before buffer: The primary controller/feed pump is arranged with existing buffer storage tank hydraulically upstream of the buffer storage tank.
- After buffer: The primary controller/feed pump is arranged with existing buffer storage tank hydraulically downstream of the buffer storage tank.

9.2.11 Boiler

■ Release below outside temp (2203)

The boiler is only put into operation if the mixed outside temperature is below the threshold set here. The switching difference is 0.5°C.

■ Full charging buffer (2208)

Under prog. no. 4810 (full charging buffer storage tank) is selected, whether and when the buffer storage tank is fully charged despite automatic generator lock. Program no. 2208 is used to set whether the boiler takes part in the full charging or not.

- Off: The boiler does {1}not{2} take part in the full charging of the buffer storage tank.
- On: The boiler takes part in the full charging of the buffer storage tank.



For more information, see
Full charging (4810), page 110

■ Setpoint min (2210) and Setpoint max (2212)

As a protection function the boiler temperature setpoint can be limited below by the minimum setpoint (prog.no. 2210) and above by the maximum setpoint (prog.no. 2212).

■ Setpoint manual control (2214)

Temperature to which the boiler is controlled in manual control mode.



For more information, see
Manual control (7140), page 126

■ **Burner running time min (2241)**

Here, the period following the commissioning of the burner is selected during which the shutdown differential is increased by 50%. However, this setting cannot guarantee that the burner remains operational for the selected period.

■ **Burner off time min (2243)**

The boiler minimum pause time only takes effect between heating requirements coming following in sequence. The boiler minimum pause time blocks the boiler for a set time.

■ **SD burner off time (2245)**

When a switching difference is exceeded, Burner off time min (prog. no. 2243) is aborted. The boiler starts despite pausing time.

■ **Pump overrun time (2250) and Pump overr time after DHW (2253)**

The delay times of the pumps are controlled according to heating mode or drinking water mode.

■ **Frost prot plant boiler pump (2300)**

Depending on the current outside temperature, the boiler pump switches on even though no heat request exists (see table below).



Important

The solid fuel tank frost protection only functions if the frost protection system (parameter 6120) is switched on.

Outside temperature	Pump
...-4 °C	ON continuously
-5 °C - +1.5 °C	ON approximately every 6 hours for 10 minutes
+1.5 °C...	OFF continuously

Off The function is switched off.

On The function is switched on.

■ **Boiler pump on heat gen lock (2301)**

Stop of boiler pump in case of activated manual heat generation lock (e.g. via H1).

- Off: Switching off not activated
- On: Switching off activated

■ **Impact heat generation lock (2305)**

This parameter is used to set whether the heat generator lock should be effective only for heating requests or also for DHW requests.

- Heating mode only: Only heating requests are locked. DHW requests are still operated.
- Heating and DHW mode: All heating and DHW requests are locked.

■ **Temp differential max (2316)**

When the pump reaches the maximum speed with the setting temperature rise nominal, the temperature difference increases via the boiler. The value set in temperature rise maximum is not exceeded. This is achieved by reducing the boiler setpoint to the current return temperature plus the value shown here.

**Caution**

Limiting the boiler rise may only be performed if a modulating heat circuit pump is configured, i.e. if program no. 6085 (Function output P1) is assigned to a heating circuit pump.

■ Temp differential nominal (2317)

The spread between boiler flow temperature and boiler return temperature is called the temperature rise.

For operation with a modulating pump, the temperature rise is specified with this parameter.

■ Pump modulation (2320)

- None: The function is switched off.
- Demand: Actuation of the boiler pump occurs at the speed calculated for the DHW pump during DHW mode or with the highest calculated speed for the max. 3 heating circuit pumps during pure heating mode. The calculated pump speed for heating circuit 2 and 3 is only evaluated if these heating circuits are also dependent on the setting of the diverting valve (parameter *boiler pump/DHW diverting valve control*).
- Boiler setpoint: The boiler pump modulates its speed so that the current setpoint (DHW or buffer storage tank) is achieved on boiler flow. The speed of the boiler pump should be increased within the specified limits until the burner has reached its upper output limit.
- Temp differential nominal: The boiler output is controlled to the boiler setpoint. The control of the pump speed controls the speed of the boiler pump so that the nominal rise between the boiler return and boiler flow is observed. If the actual rise is larger than the nominal rise, the pump speed is increased, otherwise the pump speed is reduced.
- Burner output: If the burner is operated with low output then the boiler pump should also run at low speed. During high boiler output the boiler pump should run at high speed.

■ Pump speed min (2322)

The working range can be defined in percent of output for the modulating pump. The control translates the percent data internally to speeds.

The value 0% corresponds to the minimum pump speed.

■ Pump speed max (2323)

The pump speed and with it, the power consumption can be limited via the maximum value.

■ Output nominal (2330) and Output basic stage (2331)

The settings under prog.no. 2330 and prog.no. 2331 are necessary when setting up boiler cascades with boilers of different output.

■ Output at pump speed min (2334) and Output at pump speed max (2335)

If the option burner output is selected under prog. no. 2320, the boiler pump is operated up to the set burner output under prog. no line 2334 to minimum pump speed. From the burner output set under prog. no. 2335 the boiler pump is operated on maximum pump speed. If the burner output lies between these two values, the pump speed for the boiler pump is given by linear conversion.

■ Fan parameters

- Prog.no. 2441: With this parameter the maximum boiler capacity can be limited in heating mode.
- Prog.no. 2442: With this parameter the maximum boiler capacity can be limited in full charging mode for stratification cylinders.
- Prog.no. 2444: With this parameter the maximum boiler capacity for the DHW mode can be restricted.



Important

These are calculated values. The actual output must be calculated using a gas meter, for example.

■ **Controller delay (2450)**

The controller delay is used for a stabilisation of the combustion conditions, especially after a cold start. After release of the firing automation by the controller this remains on the set output for a specified time. Modulation is only released after this time has elapsed.

Prog. no. 2450 is used to set the operating mode at which the controller delay is active.

■ **Controller delay fan output (2452)**

Boiler capacity which is used during the duration of the control delay.

■ **Controller delay duration (2453)**

Duration of the control delay. The time duration starts as soon as a positive flame is detected after ignition.

■ **Switching diff on HCs (2454), Switching diff off min HCs (2455), Switching diff off max HCs (2456), (2460), Switching diff on DHW (2461) and Switching diff off min DHW (2462) Switching diff off max DHW**

- Sd** Switching difference off
- Sd1** Switching diff off max HCs, Switching diff off max DHW
- Sd2** Switching diff off min HCs, Switching diff off min DHW
- Sd3** Switching diff on HCs, Switching diff on DHW
- t** Time
- Ti** Actual temperature

To avoid unnecessary switch off during transient effects the switch-off difference adapts dynamically depending on the temperature profile (see fig.).

Fig.29 Switching difference

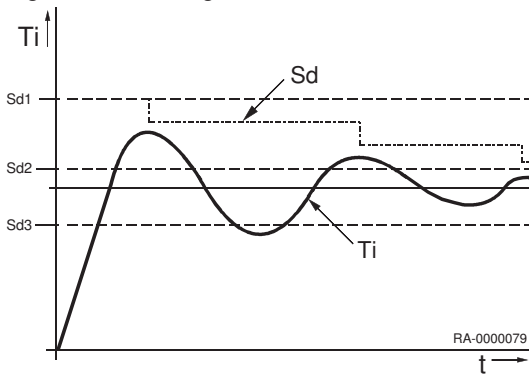

■ **Delay heat req special op (2470)**

The heat request during special operation (chimney-sweep function, controller stop, manual operation) is sent to the burner delayed by the time set here. In this way slowly opening mixers can already start up before the burner goes into operation. Thus a boiler temperature that is too high can be prevented.

■ **Static press superv sh'down (2480)**

This parameter controls behaviour when the water pressure is outside the permissible range:

- Lockout position: The boiler is locked.
- Start prevention: The boiler start-up is prevented.

■ **Pressure switch shutdown (2500)**

This function checks the static water pressure with the aid of the connected water pressure switch. Depending on the option set (*Start prevention* or *Lockout position*) a start prevention or lockout position is carried out with a corresponding diagnosis.

A closed water pressure switch releases the startup of the burner control and the actuation of the pumps. A start prevention or lockout position is triggered with the pressure switch open.

The pump actuation is also locked for protection against dry running. If the water pressure increases again and the switch closes again, this is automatically cancelled again with a start prevention and the pump actuation is released again.

■ Gas energy metering (2550)

This parameter is used to switch gas energy metering on or off. The counter values are not deleted during this process.



Important

Charging priority Absolute If the charging priority is not "Absolute" and there is a requirement for heating operation at the same time as domestic water charging, the gas energy is only taken into consideration in the meter for the heating circuit.

■ Gas energy metering readj (2551)

The gradient of the linear approximation function is adapted here.

- Value < 1: Leads to lower gas energy metering.
- Value > 1: Leads to increased gas energy metering.

A value of 1 means there is no change compared to the approximation function stored.

■ Off delay flue gas damper (2560)

The actuation of the flue damper responds to the actuation of the fan. If the fan is no longer actuated, the flue damper is closed. In order to bridge short downtimes and transitions in post-ventilation and/or hearth-drying, the flue damper is switched off with a delay. This parameter is used to set the duration of the switch-off delay.

9.2.12 Cascade

■ Lead strategy (3510)

The heat generators are switched on and off acc. to the set lead strategy taking the specified output range into account. To switch off the effect of the output range, the limits must be set to 0% and 100% and the lead strategy to late on, late off.

- Late on, early off: Additional boilers are switched on as late as possible (output range max) and switched back off again as soon as possible (output range max). I.e. as few boilers as possible in operation or short running times for additional boilers.
- Late on, late off: Additional boilers are switched on as late as possible (output range max) and switched back off again as late as possible (output range max). I.e. as few switching on and off processes as possible for the boilers.
- Early on, late off: Additional boilers are switched on as early as possible (output range min) and switched back off again as late as possible (output range min). I.e. as many boilers as possible in operation or long running times for additional boilers.

■ Release integral source seq (3530)

A value generated from temperature and time. The lag boiler is switched on when the set limit is exceeded.

■ Reset integral source seq (3531)

The following boiler will be switched off in case of exceeding the setpoint

■ Restart lock (3532)

The restart lock prevents switching a switched off boiler being switched back on again. It is only released again after the set time period has elapsed. This prevents the boiler switching on and off too often and achieves a stable operating condition of the system.

■ Switch on delay (3533)

Too frequent forward and back switching (cycles) of the boiler are avoided by the switch-on delay and therefore a stable operating state is ensured.

■ Switch-on delay DHW (3535)

In addition to parameter 3533, this function can be used to set the delay for the lag boiler to switch on when DHW charging is active. "DHW switch-on delay" applies for simultaneous heat and DHW requests.

■ Auto source seq ch'over (3540)

The sequence of lead boiler and following boiler is defined by the source sequence changeover and in this way, the utilisation of the boilers in a cascade is influenced. After the set time has elapsed, the boiler sequence is changed. The boiler with next higher device address operates as lead boiler.

The operating hours transferred from the generator to the cascade master are decisive for calculating the hours run.

The setting "- -" switches off the source sequence changeover. The lead boiler can be set under program no. 3544. The remaining boilers are connected and disconnected in the order of their LPB device addresses

■ Auto source seq exclusion (3541)

The setting for the generator exclusion is only used in connection with the activated generator sequence (program no. 3540). The generator exclusion can be used to exclude the first and/or last boiler from the automatic changeover.

- None: The boiler sequence changes after expiry of the time set in prog. no. 3540.
- First: The first boiler in the addressing works as the lead boiler; for all the other boilers the boiler sequence is changed after expiry of the time set in prog. no. 3540.
- Last: The last boiler in the addressing always remains the last boiler; for all other boilers the boiler sequence is changed after expiry of the time set in prog. no. 3540.

■ Leading source (3544)

The setting of the leading generator is only used in combination with the fixed sequence of the generator sequence (prog. no. 3540). The generator defined as the leading generator is always put into operation first, and switched off last. The other generators are switched on and off in the sequence of the device address.

■ Return setpoint min (3560)

If the return temperature drops below the return setpoint set here, the return maintenance becomes active. The return maintenance enables influences on the consumers or use of a return controller.

■ Temp differential min (3590)

This function prevents too high cascade return temperatures and improves the switch off behaviour of the cascade. If the temperature difference between the cascade flow and return sensor is smaller than the minimum temperature spread set here, a generator is switched off as early as possible independently of the set lead strategy. Once the temperature difference is sufficient again, the system is switched over to the set lead strategy again.

9.2.13 Solar

■ Solar

If there is sufficient solar energy, the solar system can heat the swimming pool, the domestic water storage tank and the buffer storage tank. The priority for heating the individual storage tanks can be set here. The system is protected by a frost protection function and an overheating protection function.

Fig.30 Charging control /schematic)

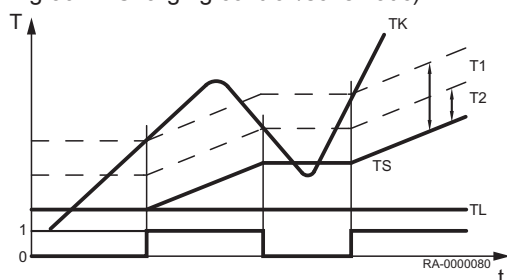

■ Temp diff on (3810) and Temp diff off (3811)

1 / 0 On / off collector pump

T Temperature

T1 Temp diff on

T0 Temp diff off

TK Collector temperature

TL Charging temperature min buffer storage tank / swimming pool

TS Storage tank temperature

t Time

The switching-on and switching-off point of the collector pump is set with these functions. Basis is the temperature difference between collector temperature and storage temperature.

■ Charge temp min DHW st tank (3812)

In addition to the temperature difference, reaching a certain minimum collector temperature is necessary for the storage charging process.

■ Temp diff on buffer (3813), Temp diff off buffer (3814), Charging temp min buffer (3815), Temp diff on swi pool (3816), Temp diff off swi pool (3817) and Charging temp min swi pool (3818)

The switch-on and switch-off point of the collector pump is set with these functions. The basis for this is the temperature difference between the collector temperature and the temperature of the buffer storage tank/ swimming pool.

In addition to the temperature difference, reaching a certain minimum collector temperature is necessary for the buffer storage tank/swimming pool charging process.

i Important

The setting "-" causes program no. 3813, 3814, 3816 and 3817 to apply the values from program no. 3810 (for program no. 3813 and 3816) and program no. 3811 (for program no. 3814 and 3817). The values from program no. 3810 and 3811 are always used for the DHW storage tank.

■ Temp diff on swi pool (3816) and Temp diff off swi pool (3817)

The solar circuit pump starts or stops if the difference between the solar collector temperature and the swimming pool temperature is exceeded or undershot.

■ Charging temp min swi pool (3818)

Temperatures that the collector must have at the least in order to begin charging a swimming pool.

■ Charging prio storage tank (3822)

If several storage tanks are connected to the system, the charging sequence can be determined by setting the charging process.

- None: Every storage tank is charged alternately with a temperature increase of 5 °C, until the setpoint has reached level A, B or C (tab. 1). Once all setpoints have been reached, the setpoints of the next level are applied.
- DHW storage tank: The DHW storage tank is charged as priority during any heating with solar energy at any level (A, B or C). Other consumers with the same level will only be charged afterwards. Once all setpoints have been reached, the setpoints of the next level are applied. For this, heating the DHW cylinder still takes priority.
- Buffer storage tank: During any heating with solar energy, the buffer storage tank is charged first at any level (A, B or C). Other consumers with the same level will only be charged afterwards. Once all setpoints have been reached, the setpoints of the next level are applied. During this process, the charging of the buffer storage tank again takes priority.

Tab.22 Storage tank setpoints

Level	Domestic water storage tank	Buffer storage tank	Swimming pool ⁽¹⁾
A	Nominal value (prog. no. 1610)	Buffer setpoint (drag-pointer)	Setpoint solar heating (prog. no. 2055)
B	Charging temp max (prog. no. 5050)	Charging temp max (prog. no. 4750)	
C	Storage tank temp max (prog. no. 5051)	Storage tank temp max (prog. no. 4751)	Swimming pool temp max (prog. no. 2070)
(1) Program no. 2065 can be used to set whether the swimming pool is charged first, between the domestic water and the buffer storage tank or last.			



For more information, see
Charging priority solar (2065), page 98

■ **Charging time relative prio (3825)**

If the preferred storage tank cannot be charged in accordance with the charging control (e.g. if the temperature difference between the priority storage tank and the collector is too small), priority will be given to the next storage tank or the swimming pool during the time set here.

■ **Waiting time relative prio (3826)**

Transfer of priority is delayed by the time selected here.

■ **Waiting time parallel op (3827)**

Parallel operation is feasible when using solar primary pumps subject to there being sufficient solar energy available. For this, in addition to the storage tank currently being heated, the next storage tank in the priority order can also be heated in parallel. The storage tank switching on for parallel operation can be delayed and stepped by the value set here.

The setting "- -" switches off parallel operation.

■ **Delay secondary pump (3828)**

The start-up of the secondary pump can be delayed to ensure that it only switches on if the primary circuit is already at the correct temperature.

■ **Collector start function (3830)**

If the temperature at the collector with the pump turned off is not measured correctly (e.g. with vacuum tubes), then a periodic switching on of the pump is possible.



Caution

The temperatures at certain collectors cannot be measured correctly if the pump is switched off. For this reason, the pump must be activated from time to time.

■ **Min run time collector pump (3831)**

The collector pump is periodically switched on for the running time set here.

■ **Collector start function on (3832) and Collector start function off (3833)**

The time when the collector start function starts or stops is set here.

■ **Collector start funct grad (3834)**

As soon as there is a temperature increase on the collector sensor, the collector pump switches on. The higher the value selected here, the greater the temperature rise must be.

- **Collector frost protection (3840)**

In order to prevent freezing of the collector, the collector pump will be activated at the temperature set here.

- **Collector overtemp prot (3850)**

In the event of a risk of overheating, charging of the storage tank will be continued in order to reduce the heat. Charging of the storage tank stops once the storage tank safety temperature has been reached.

- **Evaporation heat carrier (3860)**

Pump protecting function, to prevent overheating of the collector pump in case of evaporating danger of the heat carrying medium due to high collector temperature.

- **Pump speed min (3870) and Pump speed max (3871)**

Input of the minimum and maximum solar circuit pump speeds in percent.

- **Antifreeze (3880)**

Information of the antifreeze used.

- **Antifreeze concentration (3881)**

Input of antifreeze concentration for usage measurement of solar energy.

- **Pump capacity (3884)**

Input of the flow of the installed pump for calculation of the brought in volume for usage measurement.

If the flow rate is measured via Hx, the function must be switched off here (setting "- -"). One a value is set here, a yield measurement begins. If there are no solar yield sensors (B63/64) available, the collector sensor and storage tank sensors are used.

- **General yield measurement**

To enable precise solar yield measurement, the two additional sensors, B63 in the solar flow and B64 in the solar return, should be connected. Without these sensors a solar yield measurement is not possible.

- **Pulse unit yield (3887)**

Defines the flow per pulse for the Hx input. The Hx input must be configured to pulse count for this.

9.2.14 Solid fuel boiler

- **Solid fuel boiler**

If the solid fuel boiler temperature is high enough, the boiler pump is switched on and the domestic water storage tank and/or the buffer storage tank is heated. The solid fuel boiler requires the Solid fuel boiler sensor B22.

- **Locks other heat sources (4102)**

If the solid fuel boiler is warmed up, other heat generators, e.g. oil/gas boilers, are blocked as soon as an increase in the boiler temperature that indicates that the comparative temperature has been exceeded (program no. 4133) has been detected.

- **Setpoint min (4110)**

The boiler pump is only put into operation if the boiler temperature has reached the minimum setpoint set here in addition to the necessary temperature difference.

Fig.31 Storage tank charging

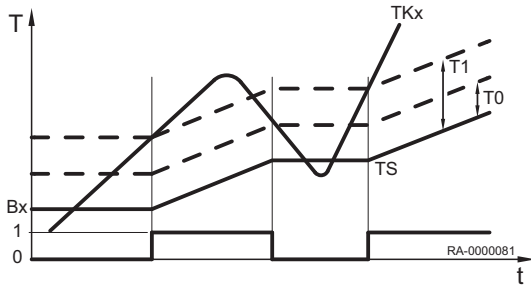

■ Temp diff on (4130), Temp diff off (4131) and Comparative temp (4133)

- 1 / 0 On / off boiler pump
- Bx Comparative actual temperature
- T1 Temp diff on
- T0 Temp diff off
- TKx Boiler temperature
- TS Storage temperature
- t Time

A sufficiently large temperature difference is necessary between the boiler temperature and the comparative temperature for start-up of the pump.

To maintain the comparative temperature, the following settings are available under prog. no. 4133:

- DHW sensor B3 / DHW sensor B31: The comparative temperature is supplied by the DHW sensor B3/B31.
- Buffer sensor B4 / Buffer sensor B41: The comparative temperature is supplied by the buffer storage tank sensor B4/B41.
- Flow temp setpoint: The flow temperature setpoint is used as comparative temperature.
- Setpoint min: The value set in prog.no. 4110 is used as comparative temperature.

■ Pump overrun time (4140)

Pump overrun time setting for the solid fuel boiler pump.

9.2.15 Buffer storage tank

■ Buffer storage tank

A buffer storage tank can be connected to the system. This can be heated via the heat generator and by solar energy. In cooling mode, it can also be used to store cooling energy. The controller controls the heating/cooling and the forced charging of the buffer storage tank, protects it against overtemperature and maintains the layering in the storage tank as far as possible.

■ Auto generation lock (4720)

The heat generator is only put into operation if the buffer can no longer cover the current heat demand. The following settings are possible:

- None: The automatic heat generator lock is deactivated.
- With B4: The automatic heat generator lock is triggered by the B4 buffer storage tank sensor.
- With B4 and B42/B41: The automatic heat generator lock is triggered by the B4 and B41 (or B42) buffer storage tank sensors.



Important

To activate the heat generator lock, the temperature must be high enough at both sensors.

■ Auto heat gen lock SD (4721)

The heat generator is locked if the the temperature in the buffer storage tank is higher than the boiler setpoint+Auto heat gen lock SD.

■ Temp diff buffer/HC (4722)

If the temperature difference between buffer storage tank and heating circuit temperature request is large enough, the heat required by the heating circuit will be taken from the buffer storage tank. The heat generator is locked. This enables a mixer boost, which is not necessary in the event of heating from the buffer, to be compensated for or, if necessary, an undersupply to be approved as well.

■ Min st tank temp heat mode (4724)

If the storage tank temperature of the buffer storage tank drops below this value, the heating circuit is switched of if no generator is available.

■ Charging temp max (4750)

The buffer storage tank is charged from solar energy up to the set charging temperature maximum.



Important

The collector overheating protection function can reactivate the collector pump until the maximum cylinder temperature (90 °C) has been reached.

■ Recooling temp (4755)

If it was necessary to charge the buffer storage tank to above the maximum charging temperature (program no. 4750), recooling down to the recooling temperature set here is carried out as soon as possible. Two functions are available for recooling the buffer storage tank down to the recooling temperature (see program no. 4756 and 4757).

■ Recooling DHW/HCs (4756)

The energy can be discharged via a heat draw by the room heating or the domestic water storage tank. This can be set separately for each heating circuit (see program no. 861, 1161, 1461).

■ Recooling collector (4757)

Recooling when the buffer storage tank temperature is too high by transmitting energy to the environment via the collector area.

- Off: Recooling has been deactivated.
- Summer: Recooling is only active in summer.
- Always: Recooling is always active.

■ With solar integration (4783)

Setting of whether the buffer storage tank can be charged by solar energy.

■ Temp diff on return div (4790), Temp diff off return div (4791) and Compar temp return div (4795)

At the appropriate temperature difference between the return sensor B73 and the selectable comparative temperature the return is re-routed to the lower buffer storage tank section. The function can either be used as return temperature increase or as return temperature decrease. The way this works is defined in prog. no.4796.

Using the definition of the temperature differences in prog. no. 4790 and 4791 the switch on and switch off point of the return redirection is established.

In prog.no. 4795 the buffer storage tank sensor is selected that delivers the value for the comparison with the return temperature, to switch on the return redirection with the aid of the set temperature differences.



Important

To activate the return redirection, a Qx relay output (program no. 5890-5892) for the Y15 buffer deflector valve and a Bx sensor input (program no. 5930-5932) for the B73 common return sensor must also be configured.

■ Optg action return diversion (4796)

The function can either be used as return temperature increase or as return temperature decrease.

- Temp decrease: If the return temperature of the consumers is higher than the temperature on the selected sensor (prog. no. 4795), the lower part of the storage tank can be preheated with the return flow. The return temperature drops even lower with this, which leads to a higher efficiency with a condensing boiler, for example.

- Temp increase: If the return temperature of the consumers is lower than the temperature on the selected sensor (prog. no. 4795), the return flow can be preheated by redirecting over the lower part of the storage tank. In this way, for example, return flow preheating can be implemented.

■ Partial charging setpoint (4800)

As a result of the hydraulic uncoupling of the lower part of the buffer storage tank, the volume of the storage tank to be heated is reduced. The remaining, upper part of the storage tank is therefore charged faster. The lower part of the storage tank is heated up first if the upper part of the storage tank is charged.

As soon as the temperature measured on the Buffer sensor B4/B42 has reached the target partial charging value, the changeover valve switches to "Pass through" and the rest of the storage tank is also charged. To do this, a Buffer return valve Y15 and a Buffer sensor B4 or Buffer sensor B42 must be configured.

■ Full charging (4810)

The {1}full charging{2} function enables the released generator to be switched off first despite the automatic generator lock if the buffer storage tank is fully charged. During active function the generator parameterized for the full charging function is only switched off when the full charging setpoint is reached or the boiler must be switched off because of burner control.

- Off: The full charging function is switched off.
- Heating mode: Full charging becomes active if the automatic generator lock blocks the heat source during valid heat request based on the buffer temperature. If the buffer storage tank reaches the requested temperature at the sensor parameterized for the full charging function, the function is ended.
- Always: Full charging becomes active if the automatic generator lock blocks the generator during valid heat request based on the buffer temperature or the heat request is invalid. If the buffer storage tank reaches the requested temperature at the sensor parameterized for the full charging function, the function is ended.

■ Full charging temp min (4811)

The buffer storage tank is charged minimally to the set value.

■ Full charging sensor (4813)

- With B4: For the full charging function the buffer storage tank sensor B4 is considered.
- With B42/B41: For the full charging function the buffer storage tank sensor B42, if not available buffer storage tank sensor B41, is considered.

9.2.16 DHW storage tank

■ DHW storage tank

The domestic water storage tank can be charged in a variety of ways:

- Via solar collectors
- Via the buffer storage tank
- Via the oil/gas boiler, the solid fuel boiler or the cascade
- Via an additional generator
- Via an immersion heater

The options available depend on the available components and their configuration. If required, the components can complement each other in the order that is most efficient in terms of energy use.

■ Forward shift charging (5011)

This setting only has an effect if the domestic water release is set in accordance with the time switching program of the heating circuit.

■ Flow setpoint boost (5020)

The boiler temperature setpoint for charging the DHW storage tank consists of the DHW temperature setpoint and the flow setpoint boost.

■ Transfer boost (5021)

Through the transfer, energy can be moved from the buffer storage tank into the DHW storage tank. For this the current buffer storage tank temperature must be higher than the current temperature in the DHW storage tank. This temperature difference is set here.

■ Type of charging (5022)

Charging a stratification cylinder (if available):

- Recharging : The cylinder is only recharged at every DHW demand.
- Full charging: The cylinder is fully charged at every DHW demand.
- Full charging legio: The cylinder is fully charged if the legionella function is enabled; otherwise it is only recharged.
- Full charg 1st time day: During the first charging of the day, the cylinder is fully charged, then recharged.
- Full charg 1st time legio: The cylinder is fully charged during the first charging of the day and if the legionella function is enabled; otherwise it is recharged

Explanations:

- Full charging: The stratification cylinder is fully charged. The heat demand is triggered by the top cylinder sensor TWF (B3), and ended by sensors TWF and TLF (B36) or TWF2 (B31). If only one B3 is installed, recharging takes place automatically.
- Recharging: The stratification cylinder is recharged i.e. only the area up to the cylinder sensor TWF (B3) is heated. The heat demand is triggered and ended by the top cylinder sensor TWF (B3).

■ Switching diff (5024)

If the DHW temperature is lower than the current setpoint minus the switching difference set here, the DHW charging is started. The DHW charging is ended if the temperature of the current setpoint is reached.



Important

At the first DHW release of the day, forced charging is performed. The DHW charging is also started if the DHW temperature is within the switching difference – as long as it is not less than 1 K under the setpoint.

■ Charging time limitation (5030)

During the domestic water charging, the room heating – depending on the selected charging priority (program no. 1630) and the hydraulic circuit – has too little or no power. It is therefore often practical to restrict the time of domestic water charging. After the set time has elapsed, domestic water charging is stopped and locked for the same amount of time before it is resumed.

■ Discharging protection (5040)

This function ensures that the DHW circulation pump (Q3) only switches on when the temperature in the heat source is high enough.

- **Application with sensor**
 - The charging pump is only switched on when the heat source temperature is above the DHW temperature plus half of the heating excess. If the boiler temperature drops below the DHW temperature plus 1/8 of the charging excess during the charging again, the charging pump is switched off again. If two DHW sensors for the DHW charging are parameterized, the lower temperature is considered for the discharge safety function (normally the DHW sensor B31).
- **Application with thermostat**
 -

The primary pump is only switched on if the boiler temperature is above the set DHW temperature. If the boiler temperature drops below the DHW nominal setpoint minus the DHW switching difference, charging pump is switched off again.

- Off: The function is switched off.
- Always: The function is always active.
- Automatically: The function is only active if the heat generator cannot deliver heat or is not available (malfunction, generator lock).

■ Discharg protec after charg (5042)

If the parameter is at "On", the discharge protection stops the domestic water pumps Q3 and Q33 from running on as soon as the DHW charging temperature drops below the storage tank temperature B3.

■ Charging temp max (5050)

With this setting, the maximum charging temperature for the connected storage of the solar system is limited. If the DHW-charging value is exceeded, the collector pump switches off.



Important

The collector pump can be re-activated by the collector overheating protection function (see programme no. 3850) until the storage tank safety temperature (90 °C) has been reached.



For more information, see

Collector overtemp prot (3850), page 107

■ Recooling temp (5055)

Once a recooling function has been activated, it remains in operation until the set Recooling temp in the domestic water storage tank has been reached.

■ Recooling collector (5057)

Recooling of the overhaeted collector through giving off of the energie to the surrounding of the collector.

■ El imm heater optg mode (5060)

- Substitute: The DHW is only heated by an immersion heater if the boiler signals a malfunction or a boiler lock exists.
- Summer: The DHW is heated by an immersion heater if all connecting heating circuits have switched to summer mode. As soon at least one heating circuit is switched to heating mode, the DHW preparation is taken over by the boiler again.



Important

The immersion heater is also used if a boiler malfunction occurs or the boiler is switched off due to a boiler lock.

- Always: DHW is heated exclusively by the immersion heater.

■ El immersion heater release (5061)

- 24h/day: Immersion heater permanently released
- DHW release: Immersion heater released subject to DHW-release (see prog. no. 1620).
- Time program 4/DHW: Release of the immersion heater via the time programme 4 of the local controller.

■ El immersion heater control (5062)

- External thermostat: The controller continuously releases the domestic water preparation with immersion heater within the release time, regardless of the storage tank temperature. The current domestic water setpoint in the controller has no effect. The required storage tank temperature must be set at the external thermostats. The manual push and the Legionella function do not work.

- DHW sensor: The controller releases the domestic water preparation with immersion heater within the release time, depending on the storage tank temperature. The current domestic water setpoint in the controller is complied with. If the sensor input B3 is designed as a thermostat, the temperature will be regulated on the basis of the contact. The manual push can be activated. If the Legionella function is active, charging will be carried out until the Legionella setpoint is reached.



Important

To ensure that the setpoint control works correctly, the thermostat outside of the controller must be set to the maximum storage tank temperature.

■ Automatic push (5070)

The DHW-push can be activated manually or automatically. It causes a one-time DHW charging to the nominal setpoint.

- Off: The DHW-push can only be activated manually.
- On: If the DHW temperature drops by more than two switching differences (prog. no. 5024) below the reduced setpoint (prog. no. 1612), it will be recharged once to the DHW nominal setpoint (prog.no.1610).



Important

The automatic push only works if the domestic water operating mode is activated (ON).

■ Excess heat draw (5085)

Excess temperature discharge can be triggered by the following functions:

- active inputs Hx
- Buffer storage tank recooling
- Solid fuel boiler excess temperature discharge

If an excess temperature discharge is activated, the excess energy can be dissipated through the heat discharge of the domestic water storage tank.

■ With buffer (5090)

If a buffer storage tank is present, it is necessary to enter whether the domestic water storage tank can be supplied heat from the heat buffer storage tank.

■ With prim contr/system pump (5092)

- No: The DHW storage tank is supplied without primary controller/feed pump.
- Yes: The DHW cylinder is supplied from the primary controller on/by the feed pump.

■ With solar integration (5093)

This function sets whether the domestic water storage tank can be charged using solar energy.

■ Pump speed min (5101) and Pump speed max (5102)

Setting of the minimum and maximum speed of the storage tank charging pump in percent.

■ Speed Xp (5103)

The P-band Xp defines the amplification of the controller. A smaller Xp value leads to a higher actuation of the charging pump with equal control difference.

■ Speed Tn (5104)

The reset time Tn determines the reaction speed of the controller when compensating for remaining controller differences. A shorter reset time Tn leads to faster compensating.

■ Speed Tv (5105)

The preholding time Tv determines how long a spontaneous change of the control difference continues to have an effect. A short time only influences the control variable only for a short time.

■ Transfer strategy (5130)

The domestic hot water storage tank can be charged from the buffer storage tank if the buffer storage tank is hot enough. Depending on the hydraulic circuit, this transfer can be carried out using the charging pump Q3 or using the St tank transfer pump Q11. If the domestic water preparation is switched off, the transfer is also switched off.

- Off: Transfer does not take place.
- Always: If the domestic water operating mode is switched on, heat is always transferred to the domestic water storage until the nominal setpoint is reached. If the Legionella function is switched on and the Legionella time is active, heat will be transferred until the Legionella setpoint is reached.
- DHW release: If the domestic water operating mode is switched on, heat is always transferred to the domestic water storage tank until the current setpoint in accordance with the domestic water release times (BZ 1620) is reached. If the Legionella function is switched on and the Legionella time is active, heat will be transferred until the Legionella setpoint is reached.

■ Interm circ boost recharging (5139)

Setpoint boost for charging setpoint on charging sensor B36 with recharging.

■ Intermediate circuit boost (5140)

Setpoint boost for the loading setpoint at the DHW charging sensor B36. The set value is added to the request.

■ Excess interm circ temp max (5141)

With this parameter the end criterion of a full charging during control is specified on the charging sensor B36. If the contents of the stratification cylinder is charged to the bottom, the temperature increases on the charging sensor

■ Flow setp compensation delay (5142)

With the setpoint control, the heat demand is adjusted so that the intermediate circuit temperature DHW charging sensor B36 reaches its setpoint (storage tank setpoint plus intermediate circuit boost). The setpoint control can be switched on or off with the flow setpoint delay parameter ("Off" or value between 0 and 60 s). The setpoint control is delayed by the length of time set under program no. 5142; the temperature is controlled to the setpoint + charging boost.

■ Flow setp compensation Xp (5143)

The mixer valve P-band Xp defines the amplification of the controller. A smaller Xp value leads to higher actuation of the charging pump at the same control difference.

■ Flow setp compensation Tn (5144)

The mixer valve reset time Tn determines the reaction speed of the controller when compensating for remaining controller differences. A shorter reset time Tn leads to faster compensating.

■ Flow setp compensation Tv (5145)

The mixer valve preholding time Tv determines how long a spontaneous change of the control difference continues to have an effect. A short time only influences the control variable for a short time.

■ Full charging with B36 (5146)

Here it can be set whether the end of the full charging is detected via the temperature on the charging sensor B36.

- No: The end of the full charging is detected via the temperature on the upper and lower storage sensor B3 and B31.
- Yes: The end of the full charging is detected via the temperature on the upper storage sensor B3 and on the charging sensor B36.

■ **Min start temp diff Q33 (5148)**

The DHW interm circ pump Q33 is only put into operation if the temperature in the generator circuit is higher than the upper domestic water storage tank temperature (B3) by at least the temperature difference set here. This maintains the temperature stratification in the storage tank. A setting of -3 °C results in the intermediate circuit pump being switched on as soon as the boiler temperature rises to within 3 °C of the storage tank temperature at B3.

■ **Excess interm circ temp del (5151)**

Control of the burner output on the charging temperature is activated if the time set here has elapsed since switching on the intermediate circuit pump.

9.2.17 Configuration

■ **Heating circuit 1 (5710), Heating circuit 2 (5715) and Heating circuit 3 (5721)**

The heating circuits can be switched on or off using this setting. Heating circuit parameters are hidden in the deactivated state.



Important

This adjustment only affects the heating circuits directly and has no influence on operation.

■ **DHW sensor B3 (5730)**

- None: No DHW sensor available.
- DHW sensor B3: There is a DHW storage tank sensor available. The controller calculates the switching points with the corresponding switching difference from the DHW setpoint and the measured DHW storage tank temperature.
- Thermostat: The domestic water temperature is regulated on the basis of the switching status of a thermostat connected to the DHW sensor B3.



Important

No reduced mode is possible when a DHW thermostat is used. This means if reduced mode is active, the DHW preparation is blocked with the thermostat.



Caution

No frost protection for DHW! The domestic water frost protection cannot be guaranteed.

■ **DHW ctrl elem Q3 (5731)**

- No charging request: DHW charging disabled via Q3.
- Charging pump: DHW charging via the connection of a charging pump to Q3/Y3.
- Diverting valve: DHW charging via the connection of a diverting valve to Q3/Y3.

■ **Basic position DHW div valve (5734)**

The base position of the diverting valve is the position in which the diverting valve (DV) is in if no request is active.

- Last request: The diverting valve (DV) remains after the last request has ended in this last position.
- Heating circuit: The diverting valve (DV) goes into the heating circuit position after the last request has ended.

- DHW: The diverting valve (DV) goes into the DHW position after the last request has ended.

■ DHW separate circuit (5736)

For multi-boiler systems (cascades), a heat generator can only be temporarily used for charging the domestic hot water. When active charging is carried out, this boiler separates itself hydraulically from the system using a domestic water isolating circuit and is no longer available for the rest of the time that heating mode is active.

- Off: The DHW separate circuit function is disabled. Each available boiler can feed the DHW storage tank.
- On: The DHW separate circuit function is enabled. The DHW charging is only done from the boiler defined for this.



Important

For a domestic water isolating circuit, the DHW ctrl elem Q3 must be set to "Diverting valve" under program no. 5731.

■ Ctrl boiler pump/DHW valve (5774)

With this parameter it can be defined for special hydraulic systems that the boiler pump Q1 and the diverting valve Q3 only are responsible for DHW and heating circuit 1, however not for heating circuits 2 and 3 or for the external consumer circuits.

- All requests: The diverting valve is connected hydraulically for all requests and switches between DHW mode and the remaining requests. The boiler pump runs for all requests.
- Request HC1/DHW only: The diverting valve is connected hydraulically only for heating circuit 1 and DHW and switches between DHW mode and heat circuit 1 mode. All other requests are not connected hydraulically via the diverting valve (DV) and the boiler pump, but rather directly connected to the boiler.

■ Boiler pump at DHW (5775)

This parameter determines, whether the boiler pump for DHW charging is switched on or off.

■ Solar controlling element (5840)

The solar heating system can also be operated with charging pumps instead of with a collector pump and diverting valves for the storage tank connection.

- Charging pump: When used with charging pump all exchangers can be flowed through simultaneously. Parallel or alternative mode is possible.
- Diverting valve: When used with a diverting valve only one exchanger can be flowed through. Only alternative mode is possible.

■ External solar exchanger (5841)

For solar schemes with two storage connections it must be set whether the external heat exchanger is present and is used *together* for DHW and buffer storage or only *for one of the two*.

■ Combi storage tank (5870)

Combined storage-specific functions are activated with this setting. For instance, the buffer storage immersion heater can be used for heating as well as for DHW.

- No: No combined storage exists.
- Yes: A combined storage exists.

■ Relay output QX1 (5890) , Relay output QX2 (5891) and Relay output QX3

- None: Relay outputs deactivated.
- Circulating pump Q4: The connected pump serves as a DHW circulation pump (see prog. no. 1660).

- El imm heater DHW K6: With the connected immersion heater, the DHW can be charged according to the operating side DHW storage operating line immersion heater.

**Important**

The operating mode is set under prog.no. 5060.

- Collector pump Q5: Connection of a circulating pump in case of solar collector use.
- Cons circuit pump VK1 Q15: Connection of a pump at the input Q15/18 for an additional consumer, which is requested via an Hx-input.
- Boiler pump Q1: The connected pump is used for recirculation of the boiler water.
- Alarm output K10: Any new fault will be signalled by means of this alarm relay. The contact is closed with the delay time selected under prog. no. 6612. If no fault message exists, the contact opens without delay.

**Important**

The alarm output is actuated with a delay of 5 minutes so that short-term faults which only lead to a restart, for example, are not displayed.

- Heat circuit pump HC3 Q20: Activating the pump heating circuit HC3.
- Cons circuit pump VK2 Q18: Activating the consumer circuit VK2.
- System pump Q14: Connection of a feed pump.
- Heat gen shutoff valve Y4: Connection of a changeover valve for hydraulic de-coupling of the heat generator from the rest of the heating system.
- Solid fuel boiler pump Q10: Connection of a circulation pump for the boiler circuit for the connection of a solid fuel boiler.
- Time program 5 K13: The relay is controlled by the time program 5 according to the settings.
- Buffer return valve Y15: This valve must be configured for the return temperature increase/reduction or partial charging of the buffer storage tank.
- Solar pump ext exch K9: The solar circuit pump for the external heat exchanger K9 must be set here.
- Solar ctrl elem buffer K8: If several exchangers are connected, the buffer storage tank must be set at the respective relay output and the type of solar regulating unit must be defined under prog.no.5840.
- Solar ctrl elem swi pool K18: If several exchangers are connected, the swimming pool must be set at the respective relay output and the type of the solar regulating unit must be defined in prog.no. 5840.
- Swimming pool pump Q19: Connection of a swimming pool pump at the input Q19 .
- Cascade pump Q25: Common boiler pump for all boilers in a cascade.
- St tank transfer pump Q11: The DHW storage tank can be heated by the buffer storage tank subject to it being hot enough. This transfer is brought about by transfer pump Q11.
- DHW mixing pump Q35: Separate pump for storage circulation during active legionella function.
- DHW interm circ pump Q33: Charging pump for DHW cylinder with external heat exchanger.
- Heat request K27: Output K27 is activated as soon as a heat demand exists in the system.
- Heat circuit pump HC1 Q2/Heat circuit pump HC2 Q6: The relay is used for actuating the heating circuit pump Q2/Q6.
- DHW ctrl elem Q3: Depending on the hydraulics a connected DHW charging pump or diverting valve.
- Status output K35: The status output is operated when a command exists from the controller to the burner control. If there is a disturbance, which prevents the burner control from operating, the status output is switched off.
- Status information K36: The output is set when the burner is in operation.

- Flue gas damper K37: This function activates the flue gas damper control. If the flue gas damper control is activated the burner will only start operating when the flue gas damper is open.
- Fan shutdown K38: This output serves to switch the fan off. The output is activated when the fan is needed; otherwise it is not activated. The fan should be switched off as often as possible in order to minimise the total energy consumption of the system.

■ Sensor input BX1 (5930), Sensor input BX2 (5931), Sensor input BX3 (5932)

Functions in addition to the basic functions are made possible by configuring the sensor inputs.

- None: Sensor inputs deactivated.
- DHW sensor B31: Lower domestic water sensor, which is used for full charging of the Legionella function.
- Collector sensor B6: First solar collector sensor in a collector field.
- DHW circulation sensor B39: Sensor for DHW circulation return.
- Buffer sensor B4: Upper buffer storage tank sensor.
- Buffer sensor B41: Lower buffer storage tank sensor.
- Common flow sensor B10: Shared flow sensor for boiler cascades or low-loss header sensors.
- Solid fuel boiler sensor B22: Sensor for the acquisition of the temperature of a solid fuel boiler.
- DHW charging sensor B36: DHW sensor for DHW charging systems.
- Buffer sensor B42: Centre buffer storage tank sensor.
- Common return sensor B73: Return sensor for the return diversion function.
- Cascade return sensor B70: Common return sensor for boiler cascades.
- Swimming pool sensor B13: Sensor for measurement of swimming pool temperature.
- Solar flow sensor B63: This sensor is required for the solar yield measurement.
- Solar return sensor B64: This sensor is required for the solar yield measurement.

■ Function input H1 (5950) Function input H4 (5970) and Function input H5 (5977)



Notice

Not all setting options are available for all H-inputs.

- None: No function.
- Optg mode change HCs+DHW: Operating mode changeover for heating circuits to reduced or protection operation (prog. no. 900, 1200, 1500) and blocking of DHW heating if contact at Hx is closed.
- Optg mode changeover HC1 to Optg mode changeover HC3: Operating mode changeover for heating circuits to protection or reduced operation.



Important

Locking of domestic hot water charging is only possible under the setting **Optg mode change HCs+DHW**.

- Heat generation lock: The boiler is locked if contact at Hx is closed. Depending on parameter 2305, the domestic hot water and consumer circuits are blocked.
The boiler is not blocked for the following functions:
 - Chimney sweep function
 - Controller stop function
 - Manual mode, 0 to 10 V output request
 - Boiler frost-protection function
- Error/alarm message: Closing the input Hx results in a control unit-internal fault message, which will also be signalled via a relay output programmed as an alarm output or in the remote management system.
- Consumer request VK1/Consumer request VK2: The set flow temperature setpoint is activated via the connecting terminals (e.g. a ventilation heater function for door curtain units).

**Important**

The setpoint is set under prog.no. 1859/1909.

- Release swi pool source heat: activation triggers heating of the swimming pool by the heat source.
- Excess heat discharge: Active excess heat discharge enables, for example, an external source to force consumers (heating circuit, DHW storage tank, Hx pump) to draw off excess heat with a signal. For each consumer the parameter excess temperature discharge can be set to determine whether the forced signal is taken into account and should therefore take part in the heat discharge or not.
- Release swi pool solar: This function enables the solar swimming pool heater to be released externally (e.g. via a manual switch) or the solar charging priority to be specified as compared to the storage.
- Operating level DHW: The operating level can be set via the contact instead of via the internal time program (external time program)
- Room thermostat HC1 to Room thermostat HC3: With the input a room thermostat request can be generated for the set heating circuit.

**Important**

The quick decrease should be switched off for the corresponding heating circuits.

- DHW thermostat: Connection of the DHW thermostat.
- Pulse count: By querying the input the low frequency pulse, e.g. for flow measurement is recorded.
- Checkb sign flue gas damper: Feedback via input H1 in case of activated flue gas damper control.
- Start prevention: With this input a burner start can be prevented. The boiler also remains blocked for all other protection functions.
- Consumer request VK1 10V/Consumer request VK2 10V: The application node external load x receives a voltage signal (DC 0...10 V) as heat request. The linear curve is defined via two fix points (voltage value 1/function value 1 and voltage value 2/function value 2 (only applies to H1).
- Output request 10V: The generator receives a voltage signal (DC 0...10 V) as output request. The linear curve is defined via two fix points (voltage value 1/function value 1 and voltage value 2 / function value 2 (only applies to H1).
- Temp measurement 10V: The controller receives a voltage signal (0 - 10 V DC) as a signal for the measured temperature. The corresponding temperature is calculated via the linear curve, which is defined via two fixed points (voltage value 1/function value 1 and voltage value 2 / function value 2).

**For more information, see**

Optg mode changeover (900, 1200, 1500), page 95

Flow temp setp cons request (1859, 1909, 1959), page 97

■ Contact type H1 (5951) Contact type H4 (5971) and Contact type H5 (5978)

With this function, the contacts can be set as resting contact (contact closed, must be opened for activating the function) or as working contact (contact opened, must be closed for activating the function).

Fig.32 Voltage_value/Function_value

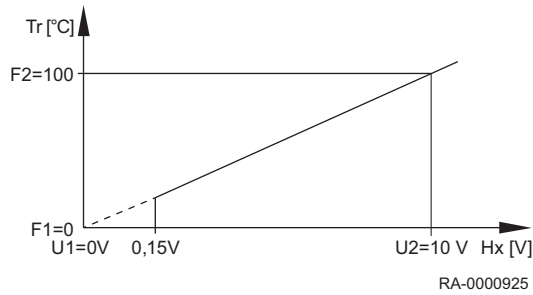

■ **Voltage value 1 H1 (5953), Voltage value 2 H1 (5955) ,
Function value 1 H1 (5954) and Function value 2 H1 (5956)**

The linear sensor curve is defined over two fixed points. The setting is made with two parameter pairs for **Funktionswert** and **Spannungswert** (F1 / U1 and F2 / U2).

The function value is specified to a factor of 10, i.e. if you require 100°C, you should select "1000".

Example: Consumer request VK1 10V

0 V = 0 °C
10 V = 100 °C

- Tr** Set point temperature
- Hx** Input value to Hx
- U1** Input value 1
- F1** Function value 1
- U2** Input value 2
- F2** Function value 2

The controller receives a voltage signal (DC 0...10 V) as a signal for the consumer request. The corresponding target value is calculated via the linear curve, which is defined via two fixed points (input value 1 = 0 v / function value 1 = 0 and input value 2 = 10 V / function value 2 = 1000). If the input signal does not reach the limit value of 0.15 V, the heat request becomes invalid and, therefore, ineffective.

■ **Frequency value 1 H4 (5973), Function value 1 H4 (5974),
Frequency value 2 H4 (5975) and Function value 2 H4 (5976)**

Fig.33 Example for two different sensor curves

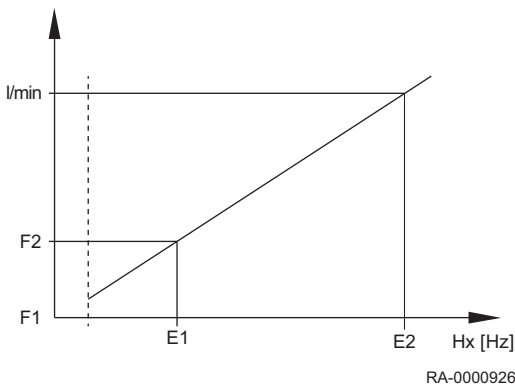

- l/min** Flow rate in litres/minute
- Hx** Input value to Hx
- E1** Input value 1 [Hz]
- F1** Function value 1
- E2** Input value 2[Hz]
- F2** Function value 2

The linear sensor curve is defined over two fixed points. The setting is made with two parameter pairs for **function value** and **frequency value**. A frequency value is used in place of the voltage values when setting the Flow measurement Hz. The controller receives a signal for the measured flow rate. The corresponding flow rate is calculated via the linear curve, which is defined via two fixed points (input value 1/function value 1 and input value 2/function value 2).

■ **Function output P1 (6085)**

A speed signal can be output at output P1 for the following pumps:

None | Boiler pump Q1 | DHW pump Q3 | DHW interm circ pump Q33 | Heat circuit pump HC1 Q2 | Heat circuit pump HC2 Q6 | Heat circuit pump HC3 Q20 | Collector pump Q5 | Solar pump ext exch K9 | Solar pump buffer K8 | Solar pump swi pool K18

■ **Signal logic output P1 (6086)**

The PWM output P1 can be output inverted using signal logic output P1.

■ **Sensor type collector (6097)**

Selection of used sensor types for measurement of the collector temperature.

■ **Readjustm collector sensor (6098)**

Setting a correction value for collector sensor 1.

■ **Readjustm outside sensor (6100)**

Setting a correction value for outside sensor.

■ Time constant building (6110)

The value set here influences the reaction speed of the flow setpoint in case of fluctuating outside temperatures as a function of the building design.

Example values (refer also to Quick setback):

- 40 for buildings with thick walls or outer insulation.
- 20 for buildings of normal building design.
- 10 for buildings of light building design.



For more information, see

Quick setback (780, 1080, 1380), page 91
Optimum start control max (790, 1090, 1390) and Optimum stop control max (791, 1091, 1391), page 92

■ Central setp compensation (6117)

The central setpoint lead monitors the heat generator setpoint to the required central flow temperature. With the setting the maximum corrector is restricted, even if a larger adaptation should be required.

■ Frost protection plant (6120)

The heating circuit pump is activated without heat request subject to outside temperature. If the outside temperature reaches the lower limit value of -4°C , the heating circuit pump is activated. The pump is activated every 6 hours for 10 minutes when the outside temperature is between -5°C and $+1.5^{\circ}\text{C}$. When the upper limit value of 1.5°C is reached, the pump switches off.

■ Water pressure min (6181)

A maintenance message is indicated from this set water pressure. The boiler output is reduced by 20% to protect the boiler. The message is only reset when the set pressure has been exceeded by 0.2 bar.

■ Save sensors (6200)

Sensor modes can be saved under prog. no. 6200. This is done automatically; however, after change of the heating system (removal of a sensor) the state must be saved again to the sensor terminals.

■ Reset to default parameters (6205)

The factory setting of the regulator is written to the regulator.



Caution

The regulator parameters are overwritten. The factory settings are stored in the regulator.

- Activation of prog. no. 6205:
The regulator is reset to **factory setting**.

■ Check no. heat source 1 (6212), Check no. heat source 2 (6213), Check no. storage tank (6215) and Check no. heating circuits (6217)

The standard device generates a check number to identify the system scheme; this comprises the numbers listed in the table below.

Tab.23 Check no. heat source 1 (prog.-no. 6212)

Number (part 1)	Solar					Boiler		
	K8 ⁽¹⁾	K8 ⁽²⁾	K18 ⁽³⁾	K18 ⁽⁴⁾	K9 ⁽⁵⁾	Number (part 2)	Modulating burner	Boiler pump
0	No solar					00	No boiler	
1					⁽⁶⁾	01		
3					DHW/B	02		
5	X					03		X
6		X				04		X

Solar						Boiler		
Number (part 1)	K8 ⁽¹⁾	K8 ⁽²⁾	K18 ⁽³⁾	K18 ⁽⁴⁾	K9 ⁽⁵⁾	Number (part 2)	Modulating burner	Boiler pump
8	X				DHW+B	05		
9		X			DHW/B	06		
10	X				DHW	07		X
11		X			DHW	08		X
12	X				B	09		X
13		X			B	10		X
14			X			11	X	
15				X		12	X	X
17			X		DHW/B	13	X	
18				X	DHW/B	14	X	X
19	X		X			15	X	X
20		X		X				
22	X				DHW+B			
23		X		X	DHW/B			
24	X		X		DHW			
25		X		X	DHW			
26	X		X		B			
27		X		X	B			

- (1) Storage tank charging pump for bufferstorage tank **K8**
(2) Solar diverting valve for bufferstorage tank **K8**
(3) Solar charging pump for swimming pool **K18**
(4) Solar diverter valve for swimming pool **K18**
(5) External solar exchanger, Solar pump **K9**; DHW=DHW storage tank, B=Buffer storage tank
(6) The domestic hot water storage tank is charged using collector pump Q5

Tab.24 Check no. heat source 2 (prog.-no. 6213)

Solid fuel boiler	
0	No solid fuel boiler
1	Solid fuel boiler, boiler circuit pump
2	Solid fuel boiler, boiler pump, integration of DHW storage tank

Tab.25 Check no. storage tank (prog.-no. 6215)

Buffer storage tank		Domestic water storage tank	
0	No buffer storage tank	0	No DHW storage tank
1	Buffer storage tank	1	Immersion heater
2	Buffer storage tank, solar connection	2	Solar connection
4	Buffer storage tank, heat generation shutoff valve	4	Primary pump
5	Buffer storage tank, solar connection, source shut-off valve	5	Charging pump, solar connection
		13	Diverter valve
		14	Diverting valve, solar connection
		16	Primary controller, without heat exchanger
		17	Primary controller, 1 heat exchanger
		19	Intermediate circuit, without heat exchanger
		20	Intermediate circuit, 1 heat exchanger
		22	Primary pump/intermediate circuit, without heat exchanger
		23	Charging pump/intermediate circuit, 1 heat exchanger
		25	Diverting valve, intermediate circuit, without heat exchanger
		26	Diverting valve, intermediate circuit, 1 heat exchanger

Buffer storage tank		Domestic water storage tank	
		28	Primary controller/intermediate circuit, without heat exchanger
		29	Primary controller/intermediate circuit, 1 heat exchanger

Tab.26 Check no. heating circuit (prog.-no. 6217)

Heating circuit 3		Heating circuit 2		Heating circuit 1	
0	No heating circuit	00	No heating circuit	00	No heating circuit
1	DHW circulation via boiler circuit pump	01	DHW circulation via boiler circuit pump	01	DHW circulation via boiler circuit pump
2	Heating circuit pump	02	Heating circuit pump	02	Heating circuit pump
3	Heating circuit pump, mixer	03	Heating circuit pump, mixer	03	Heating circuit pump, mixer

■ Software version (6220)

Display of the actual software version.

■ Info 1 OEM(6230), Info 2 OEM (6231), Info 3 OEM (6258), Info 4 OEM (6259) and Parameter set number OEM (6236)

These parameters are EEPROM storage locations that may contain information from the OEM.

9.2.18 LPB system

■ Device address (6600) and Segment address (6601)

The two-part LPB address of the controller consists of the 2-digit segment number and the 2-digit device number.

■ Bus power supply function (6604)

- Off: The controller does not provide the bus power supply.
- Automatically: The bus power supply is switched on and off by the controller in accordance with the power demand of the bus system.

■ Bus power supply state (6605)

- Off: The bus system power supply by the controller is currently inactive.
- On: The bus system power supply by the controller is currently active.

■ Display system messages (6610)

This setting allows system messages which are transmitted via LPB to be suppressed on connected operating elements.

■ System message to alarm relay (6611)

- No: Alarm output K10 is not triggered when a system fault is reported.
- Yes: Alarm output K10 is triggered when a system fault is reported.

■ Alarm delay (6612)

The transmission of the alarm to the BM module can be delayed in the basic device by an adjustable time. This allows the prevention of unnecessary messages to a service location caused by malfunctions which only occur briefly (e.g. temperature monitor queried, communication errors). However, it must be noted that malfunctions which occur briefly and quickly re-occur are also filtered out by this.

■ Action changeover functions (6620)

If the setting Central is activated under prog. no. 6221 and 6223 respectively, the action for this setting can be set. The following settings are possible:

- Segment: The changeover is done for all controllers in the same segment.
- System: The changeover is done for all controllers in the entire system (that is in all segments). The controller must be located in segment 0!

■ Summer changeover (6621)

- Locally: The local heating circuit is switched on and off depending on prog.no. 730, 1030 or 1330.
- Centrally: Depending on the settings made in prog. no. 6620, either the heating circuits in this section or all heating circuits in the entire system are switched on and off.

■ Optg mode changeover (6623)

- Locally: The local heating circuit is switched on and off.
- Centrally: Depending on the settings made in prog. no. 6620, either the heating circuits in this section or all heating circuits in the entire system are switched on and off.

■ Manual source lock (6624)

- Locally: The local generator is locked.
- Segment: All generators in the cascade are locked.

■ DHW assignment (6625)

The domestic hot water assignment stipulates from which heating circuits/cooling circuit the operating mode for the controller of the domestic hot water charging (bringing forward the charging, operating the circulation pump, holiday function) should be taken into consideration.

- Local HCs: The domestic hot water charging only takes into consideration the separate heating circuits/cooling circuit inside the controller.
- All HCs in segment: The domestic hot water charging takes into consideration heating circuits/cooling circuit for the controller in the same segment.
- All HCs in system: The domestic hot water charging takes into consideration heating circuits/cooling circuit for all of the controllers in the system.



Important

For all settings, the controllers that are in holiday status are also taken into consideration for the DHW preparation.

■ Note OT limit ext source (6632)

Additional generators connected via the LBP bus can be locked or released according to their own parameters based on the outside temperature (e.g. air heat pump/water heat pump). This status is distributed via LPB. The master thus knows via a cascade whether an additional generator (slave) is available according to its own application limits (outside temperature) or not, and can then connect another generator accordingly.

- No: External generator is not taken into account.
- Yes: The external generator is taken into account and the cascade is controlled according to the available generators.



Important

If an ISR-Plus regulator (slave) is connected a further generator, this parameter must be set to "No".

■ Clock mode (6640)

This setting determines the effect of the system time on the controller time setting. The following settings are possible:

- Autonomously: The time can be adjusted at the controller. The time of the controller is not adapted to the system time.
- Slave without remote setting: The time cannot be adjusted at the controller. The controller time is constantly synchronised to the system time.

- Slave with remote setting: The time can be adjusted at the controller. The system time is synchronised simultaneously as the change is adopted by the master. The time of the controller is then continually adapted to the system time.
- Master: The time can be adjusted at the controller. The controller time is defaulted to the system. The system time is adapted.

■ Outside temp source (6650)

In the LPB system only one single outside temperature sensor is necessary. This delivers the signal via the LPB to the controllers without a sensor. The first figure in the display is the section number, the second is the appliance number.

9.2.19 Modbus

■ General

The Modbus interface can be used to connect to the control system or operating unit to exchange process and operating values.



See

You can find further information in the *Accessory instructions* for the Modbus interface.

9.2.20 Fault

■ Message (6700)

A current existing error in the system is displayed here in the form of an error code.

■ Display SW diagnostic code (6705)

In case of a fault, the display fault is on permanently. In addition, the diagnosis code is displayed on the display.

■ Burn ctrl phase lockout pos (6706)

Phase during which the fault occurred which led to the failure.

■ Reset alarm relay (6710)

An output relay QX, programmed as an alarm relay can be reset via this setting.

■ Flow temp 1 alarm (6740), Flow temp 2 alarm (6741), Flow temp 3 alarm (6742), Boiler temp alarm (6743), DHW charging alarm (6745)

Setting the time after which a fault message will be triggered in case of persisting deviation from temperature nominal and actual values.

■ Error history / Error codes (6800-6995)

The last 20 error messages with error codes and time of occurrence are saved to the error memory.

9.2.21 Maintenance / special operation

■ Burner hours interval (7040)

Setting of the interval for maintenance of the burner.

■ Burn hrs since maintenance (7041)

Burner hours since the last maintenance.



Important

The burner hours are only counted, when the maintenance message has been activated.

■ Burner start interval (7042)

Setting of the interval for burner starts for maintenance.

■ Burn starts since maint (7043)

Burner starts since the last maintenance.



Important

The burner starts are only counted, when the maintenance message has been activated.

■ Maintenance interval (7044)

Setting of maintenance interval in months.

■ Time since maintenance (7045)

Passed time since the last maintenance interval.



Important

The time is only counted, when the maintenance message has been activated.

■ Fan speed ionization current (7050)

Speed limit from which the ionisation current service alarm should be set (prog. no. 7051), if the ionisation current monitoring and therefore a speed increase based on too low ionisation current active is.

■ Message ionization current (7051)

Function for display and reset of the burner ionization current maintenance message. The maintenance message can only be reset if the reason for maintenance has been eliminated.

■ Chimney sweep function (7130)

The chimney sweep function is switched on or off under this prog no.



Important

The function is switched off by the setting **Off** or automatically if the maximum boiler temperature is reached.

It can also be directly activated via the chimney sweep button.

■ Manual control (7140)

Activation of manual control. If the manual control function is activated the boiler is controlled to the setpoint manual control. All the pumps are switched on. Additional request will be ignored!

■ Controller stop function (7143)

If the controller stop function is activated, the burner output set in the setpoint controller stop is directly requested by the device.

■ Controller stop setpoint (7145)

With activated controller stop function the output set here is requested by the device.

■ Compulsory heat draw-off DHW (7165)

This parameter is used to set that heat pumping to the domestic hot water circuit takes priority when the chimney sweep function is active.

- Off: Compulsory pumping of the heat to the heating circuits.
- On: When the chimney sweep function is active, heat is pumped with priority into the domestic hot water circuit.

■ Telephone customer service (7170)

Here the desired telephone number of customer service can be entered.

■ PStick storage pos (7250)

Via the parameter PStick storage pos the data set (data set number on the stick) can be selected which should be written or read.

If a data set is selected, the name of the data set is displayed bottom. For backup sticks the data set name is displayed in the format BUYMMDDHHMM (BU for backup and date of backup: Year, Month, Day, Hour, Minute). As soon as a data set number is selected, the text is displayed for the data set description.

■ PStick command (7252)

- No operation: This is the basic state. As long as no operation is active on the stick, this command is displayed.
- Reading from stick: Starts reading the data from the stick. This operation is only possible with READ sticks. The data of the set data set is copied to the LMS control. First a check is carried out as to whether the data set may be imported. If the data set is incompatible, it must not be imported. The display resets to No operation and displays an error message. The text Reading from stick remains until the operation is completed or an error occurs. As soon as data transmission begins, the LMS control goes in a parameterization position. As soon as parameters are transferred, the LMS control must be unlocked transmission has ended. Fault 183 parameterization is displayed.
- Writing on stick: Starts writing the data from the LMS control to the stick. This operation is only possible with WRITE sticks. The data is written into the previously set data set. Before writing of the data begins, it is checked whether the stick has sufficient capacity for the data and that the respective customer number is correct. The text Writing on stick remains until the operation is completed or a fault occurs.

■ PStick progress (7253)

The read or write progress is displayed as a percentage. If no operation is active or a fault occurs, 0% is displayed.

The stick status is shown below:

- No stick: The LMS control has not detected a stick (the stick may not be inserted).
- Stick ready: Basic condition, stick is detected, no action active, no error present.
- Writing on stick: Data is copied (backup) from the LMS control to the stick.
- Reading from stick: Data is transferred from the stick to the LMS control.
- Writing error: An error occurred when copying the data from the LMS control to the stick. The operation was aborted.
- Reading error: An error occurred when copying the data from the stick to the LMS control.. The operation was aborted. The control LMS is locked. Status change to read lock.
- Incompatible data set: Data set does not match LMS control. Compatibility conditions are not met. The data set can not be imported.
- Wrong stick type: Stick type does not match selected action. E.g. reading from write stick or writing to read stick is not possible.
- Stick format error: Incorrect customer number on the stick or data format on the stick is unknown and cannot be evaluated by the LMS control.
- Check data set: During transmission of a data set from the stick to the LMS control a problem occurred, but it did not lead to an abort.
- Data set disabled: The data set may not be transferred into the LMS control (read protected).

9.2.22 Configuration of extension modules

■ Function extension module 1 (7300), Function extension module 2 (7375) and Function extension module 3 (7450)

When a function is selected, the inputs and outputs are occupied on the extension module with the functions according to the following table:

Connection terminal on module	QX21	QX22	QX23	BX21	BX22	H2/H21	H22
Multifunctional	*	*	*	*	*	*	*
Heating circuit 1	Y1	Y2	Q2	B1	*	*	*

Connection terminal on module	QX21	QX22	QX23	BX21	BX22	H2/H21	H22
Heating circuit 2	Y5	Y6	Q6	B12	*	*	*
Heating circuit 3	Y11	Y12	Q20	B14	*	*	*
Solar DHW	*	*	Q5	B6	B31	*	*
Primary contr/ system pump	Y19	Y20	Q14	B15	*	*	*

* Freely selectable in QX.../ BX...
FS = DHW flow switch; AVS75.390 = H2; AVS75.370 = H21

Tab.27 Legend

Q1	Boiler pump
Q2	1. Heating circuit pump
Q5	Collector pump
Q6	2. Heating circuit pump
Q14	System pump
Q20	Heating circuit pump HC3
Y1	1. Heating circuit mixer OPEN
Y2	1. Heating circuit mixer CLOSED
Y5	2. Heating circuit mixer OPEN
Y6	2. Heating circuit mixer CLOSED
Y11	3. Heating circuit mixer OPEN
Y12	3. Heating circuit mixer CLOSED
Y19	Primary control mixer OPEN
Y20	Primary control mixer CLOSED
B1	Flow sensor HC1
B6	Collector sensor
B12	Flow sensor HC2
B14	Flow sensor HC3
B15	Flow sensor primary control

■ **Relay output QX21 module 1 (7301), Relay output QX22 module 1 (7302), Relay output QX23 module 1 (7303), Relay output QX21 module 2 (7376), Relay output QX22 module 2 (7377), Relay output QX23 module 2 (7378), Relay output QX21 module 3 (7451), Relay output QX22 module 3 (7452) and Relay output QX23 module 3 (7453)**

- None: Relay outputs deactivated.
- Circulating pump Circulating pump Q4: The connected pump serves as DHW-circulating pump (see programme number 1660).
- El imm heater DHW K6: With the connected immersion heater, the DHW can be charged according to the operating side DHW storage operating line immersion heater.



Important

The operating mode is set under prog.no. 5060.

- Collector pump Q5: Connection of a circulating pump in case of solar collector use.
- Cons circuit pump VK1 Q15/Cons circuit pump VK2 Q18: Connection of a pump at the input Q15/18 for an additional consumer, which is requested via an Hx-input.
- Boiler pump Q1: the connected pump is used for recirculation of the boiler water.
- Bypass pump Q12: the connected pump is used as a boiler bypass pump, which is used for boiler return temperature control.

- Alarm output K10: in case of a fault, this will be signalled by the alarm relay. The contact is closed with the delay time selected under prog. no. 6612. If no fault message exists, the contact opens without delay.



Important

The alarm relay can be reset without having the fault remedied (see prog. no. 6710). The alarm relay can also be closed temporarily by a message which, for example, leads to restart.

- Heat circuit pump HC3 Q20: Activating the pump heating circuit HC3.
- System pump Q14: Connection of a feed pump.
- Heat gen shutoff valve Y4: Connection of a changeover valve for hydraulic de-coupling of the heat generator from the rest of the heating system.
- Solid fuel boiler pump Q10: Connection of a circulation pump for the boiler circuit for the connection of a solid fuel boiler.
- Time program 5 K13: the relay will be controlled by the time program 5 according to the settings.
- Buffer return valve Y15: This valve must be configured for return temperature increase/decrease or the buffer storage tank partial charging.
- Solar pump ext exch K9: here, the solar pump external exchanger K9 must have been set for the external heat exchange.
- Solar ctrl elem buffer K8: if several exchangers are connected, the buffer storage must be set at the respective relay output and the type of solar regulating unit must be defined under prog.no.5840
- Solar ctrl elem swi pool K18: If several exchangers are connected, the swimming pool must be set at the respective relay output and the type of the solar regulating unit must be defined in prog.no. 5840.
- Swimming pool pump Q19: Connection of a swimming pool pump at the input Q19.
- Cascade pump Q25: Common boiler pump for all boilers in a cascade.
- St tank transfer pump Q11: the drinking water storage can be charged from the buffer storage, if is sufficiently hot. This transfer is brought about by transfer pump Q11.
- DHW mixing pump Q35: separate pump for storage circulation during active legionella function.
- DHW interm circ pump Q33: Charging pump for DHW cylinder with external heat exchanger.
- Heat request K27: as soon as a heat demand exists in the system, the output K27 will be activated.
- Heat circuit pump HC1 Q2/Heat circuit pump HC2 Q6: The relay is used for actuating the heating circuit pump Q2/Q6.
- DHW ctrl elem Q3: depending on the hydraulics a connected DHW charging pump or diverting valve.
- Status output K35: The status output is operated when a command exists from the controller to the burner control. If there is a disturbance, which prevents the burner control from operating, the status output is switched off.
- Fan shutdown K38: This output serves to switch the fan off. The output is activated when the fan is needed; otherwise it is not activated. The fan should be switched off as often as possible in order to minimise the total energy consumption of the system.

■ Sensor input BX21 module 1 (7307), Sensor input BX22 module 1 (7308), Sensor input BX21 module 2 (7382), Sensor input BX22 module 2 (7383), Sensor input BX21 module 3 (7457) and Sensor input BX22 module 3 (7458)

Functions in addition to the basic functions are made possible by configuring the sensor inputs.

- None: Sensor inputs deactivated.
- DHW sensor B31: Lower domestic water sensor, which is used for full charging of the Legionella function.
- Collector sensor B6: First solar collector sensor in a collector field.
- DHW circulation sensor B39: Sensor for DHW circulation return.
- Buffer sensor B4: Upper buffer storage tank sensor.

- Buffer sensor B41: Lower buffer storage tank sensor.
- Common flow sensor B10: Shared flow sensor for boiler cascades or low-loss header sensors.
- Solid fuel boiler sensor B22: Sensor for the acquisition of the temperature of a solid fuel boiler.
- DHW charging sensor B36: DHW sensor for DHW charging systems.
- Buffer sensor B42: Centre buffer storage tank sensor.
- Common return sensor B73: Return sensor for the return diversion function.
- Cascade return sensor B70: Common return sensor for boiler cascades.
- Swimming pool sensor B13: Sensor for measurement of swimming pool temperature.
- Solar flow sensor B63: This sensor is required for the solar yield measurement.
- Solar return sensor B64: This sensor is required for the solar yield measurement.

■ **Function input H2/H21 module 1 (7321) , Function input H2/H21 module 2 (7396) and Function input H2/H21 module 3 (7471)**

- None: no function.
- Optg mode change HCs+DHW: Changeover of the operating modes of the heating circuits to reduced or protection operation (prog.nos. 900, 1200, 1500) and locking of domestic hot water charging in case of closed contact at H2/H21/H22.
- Optg mode changeover DHW: Locking of the domestic hot water charging in case of closed contact at H2/H21/H22/.
- Optg mode changeover HCs: Operating mode changeover for heating circuits to protection or reduced operation.



Important

Locking of domestic hot water charging is only possible under the setting **Optg mode change HCs+DHW**.

- Heat generation lock: the heat generator is locked through connecting terminal H2/H21. All temperature demands for heating circuits and DHW are ignored. The boiler frost protection function is maintained.



Important

The chimney sweeper function can be applied in spite of the heat generation lock.

- Error/alarm message: Closing the inputs Hx results in a control unit-internal fault message, which will also be signalled via a relay output programmed as an alarm output or in the remote management system.
- Consumer request VK1/Consumer request VK2: the set flow temperature setpoint is activated via the connecting terminals (e.g. a ventilation heater function for door curtain units).



Important

The setpoint must be set under progr. no. 1859/1909/1959.

- Release swi pool source heat: closing the input Hx (e.g. manual switch) enables the swimming pool heater. Heating is performed by means of 'heat generator heating'.
- Excess heat discharge: an active excess heat discharge enables, for example, an external source to force the consumers (heating circuit, DHW storage tank, heating circuit pump) to draw off the excess heat using a signal.
- Release swi pool solar: this function enables the solar swimming pool heater to be released externally (e.g. via a manual switch) or the solar charging priority to be specified as compared to the storage.
- Operating level DHW/HCs: The operating level can be set via the contact instead of via the internal time program (external time program).
- Ambient thermostat HCs: With the input a room thermostat request can be generated for the set heating circuit.

**Important**

The quick decrease should be switched off for the corresponding heating circuits.

- DHW thermostat: Connection of the DHW thermostat.
- Limit thermostat HC: If the extension module is used for the heating circuit, an external temperature monitor can be cut in at the inlet (e.g. for underfloor heating).
- Start prevention: With this input a burner start can be prevented.
- Consumer request VK1 10V/Consumer request VK2 10V: the application node external load x receives a voltage signal (DC 0-10 V) as heat request. The linear curve is defined via two fix points (input value 1/function value 1 and input value 2/function value 2).
- Output request 10V: The generator receives a voltage signal (DC 0...10 V) as output request. The linear curve is defined via two fix points (voltage value 1/function value 1 and voltage value 2 / function value 2 (only applies to H1).
- Temp measurement 10V: The controller receives a voltage signal (0 - 10 V DC) as a signal for the measured temperature. The corresponding temperature is calculated via the linear curve, which is defined via two fixed points (input value 1/function value 1 and input value 2/function value 2). The use of the measured temperature is defined via program no. 5957 and 5967.

■ **Contact type H2 module 1 (7312), Contact type H2/H21 module 1 (7322), Contact type H2 module 2 (7387), Contact type H2/H21 module 2 (7397) , Contact type H2 module 3 (7462)**

With this function, the contact can be set as a normally closed contact (contact closed, must be opened to activate the function) or as a normally open contact (contact opened, must be closed to activate the function).

■ **Voltage value 1 H2 module 1 (7314) to Funct value 2 H2 module 1 (7317), Voltage value 1 H2 module 2 (7389) to Funct value 2 H2 module 2 (7392)**

Fig.34 Example of heat demand 10 V

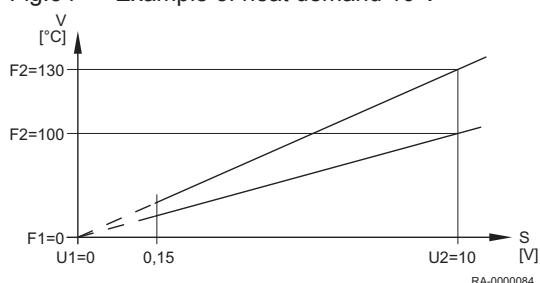

- F1 Function value 1
- F2 Function value 2
- S Voltage to Hx
- U1 voltage value 1
- U2 voltage value 2
- V Flow temperature setpoint

The linear sensor curve is defined over two fixed points. The setting is made with two parameter pairs for **Funktionswert** and **Spannungswert** (F1 / U1 and F2 / U2).

**Important**

For further description, see examples under Input value 1 H1 (5953) ff.

■ **Funct input EX21 module 1 (7342) , Funct input EX21 module 2 (7417) and Funct input EX21 module 3 (7492)**

- None: No function.
- Limit thermostat HC: If the extension module is used for the heating circuit, an external temperature monitor can be install in at the inlet EX21 (e.g. for underfloor heating). If the temperature monitor is activated: - The mixer is closed and the pump is switched off - A fault message is issued (temperature monitor HKx) - The status "Monitor activated is generated. If the function of the expansion module is set on heating circuit 1-3 and the function of input EX21 for the same module is set on the temperature monitor (HK), in this case, the status at input EX21 is taken into consideration internally for controlling the relay outputs (pump and mixer open/closed).

■ **Funct output UX21 module 1 (7348), Funct output UX22 module 1 (7355), Funct output UX21 module 2 (7423), Funct**

output UX22 module 2 (7430) , Funct output UX21 module 3 (7498) and Funct output UX22 module 3 (7505)

- None: No function.
- Boiler pump Q1: The connected pump is used for recirculation of the boiler water.
- DHW pump Q3: Actuator for DHW storage tank.
- DHW intermediate circuit pump Q33: Actuation of a charge pump for domestic hot water storage with external heat exchanger.
- Heating circuit pumps HCs: Activation of the pump heating circuits HC1- HC3.
- Collector pump Q5: Actuation of a circulating pump when a solar collector is used.
- Solar pump ext. exchanger K9: The solar circuit pump for the external heat exchanger K9 must be set here.
- Solar pump buffer K8: If several exchangers are connected, the buffer storage tank must be set at the respective relay output and the type of solar regulating unit must be defined under prog.no.5840.
- Solar pump swimming pool K18: If several exchangers are connected, the swimming pool must be set at the respective output and the type of the solar regulating unit must be defined in prog.no. 5840.

■ Signal output UX21 module 1 (7350), Sign logic out UX22 module1 (7357), Signal output UX21 module 2 (7425) and Signal output UX22 module 2 (7432), Signal output UX21 module 3 (7500) und Signal output UX22 module 3 (7507)

Specifies whether the signal is to be output as a 0 - 10 V signal or pulse-width modulated (PWM) signal.

9.2.23 Input/output test

■ Input/output tests

Tests for checking the function of connected components.

9.2.24 Status

■ State

With this function the status of the selected system can be requested.

Tab.28 Status table heating circuit

The following messages are possible under **Heating circuit**:

End user (Eu)	Commissioning, Engineer (menu Status)
Limiter has tripped	Limiter has tripped
Manual control active	Manual control active
Floor curing function active	Floor curing function active
Heating mode restricted	Overtemp prot active
	Restricted, boiler protection
	Restricted, DHW priority
	Restricted, buffer
Forced draw	Forced draw DHW
	Forced draw source
	Overrun active
Comfort heating mode	Opt start ctrl+boost heating
	Optimum start control
	Boost heating
	Comfort heating mode
Reduced heating mode	Optimum stop control
	Reduced heating mode

End user (Eu)	Commissioning, Engineer (menu Status)
Frost protection active	Frost prot room active
	Frost protection flow active
	Frost prot plant active
Summer operation	Summer operation
Off	24-hour Eco active
	Setback reduced
	Setback frost protection
	Room temp limitation
	Off

Tab.29 Status table domestic water

The following messages are possible under **Drinking water**:

End user (Eu)	Commissioning, Engineer (menu Status)
Limiter has tripped	Limiter has tripped
Manual control active	Manual control active
Consumption	Consumption
Keep hot mode on	Keep hot mode active
	Keep hot mode on
Recooling active	Recooling via collector
	Recooling via heat gen/HCs
	Recooling via DHW/HCs
Charging lock active	Discharging prot active
	Charg time limitation active
	Charging locked
Forced charging active	Forced, max st tank temp
	Forced, max charging temp
	Forced, legionella setp
	Forced, nominal setp
Charg el imm heater	El charging, legionella setp
	El charging, nominal setp
	El charging, reduced setp
	El charging, frost prot setp
	El imm heater released
Push active	Push, legionella setp
	Push, nominal setp
Charging active	Charging, legionella setp
	Charging, nominal setp
	Charging, reduced setp
Frost protection active	Frost protection active
	Frost prot instant WH
Overrun active	Overrun active
Standby charging	Standby charging
Charged	Charged, max st tank temp
	Charged, max charging temp
	Charged, legionella temp
	Charged, nominal temp
	Charged, reduced temp
Off	Off
Ready	Ready

Tab.30 Status table boiler

The following messages are possible under **Boiler**:

End user (Eu)	Commissioning, Engineer (menu Status)
SLT has tripped	SLT has tripped
Fault	Fault
Limiter has tripped	Limiter has tripped
Manual control active	Manual control active
Chimney sweep funct active	Chim sweep fct, high-fire
	Chim sweep fct, low-fire
Locked	Locked, manual
	Locked, solid fuel boiler
	Locked, automatic
	Locked, outside temp
	Locked, Economy mode
Min limitation active	Min limitation
	Min limitation, low-fire
	Min limitation active
In operation	Protective start
	Protective start, low-fire
	Return limitation
	Return limitation, low-fire
Charging buffer	Charging buffer
In part load op for HC, DHW	In part load op for HC, DHW
In part load op for HC, DHW	In part load op for HC, DHW
Released for HC, DHW	Released for HC, DHW
In operation for DHW	In operation for DHW
In part load op for DHW	In part load op for DHW
Released for DHW	Released for DHW
In operation for HC	In operation for HC
In part load op for HC	In part load op for HC
Released for HC	Released for HC
Overrun active	Overrun active
Released	Released
Frost protection active	Frost protection active
Off	Off

Tab.31 Status table solar

The following messages are possible under **Solar**:

End user (Eu)	Commissioning, Engineer (menu Status)
Manual control active	Manual control active
Fault	Fault
Frost prot collector active	Frost prot collector active
Recooling active	Recooling active
Max st tank temp reached	Max st tank temp reached
Evaporation prot active	Evaporation prot active
Overtemp prot active	Overtemp prot active
Max charging temp reached	Max charging temp reached
Charg DHW+buffer+swi pool	Charg DHW+buffer+swi pool
Charging DHW+buffer	Charging DHW+buffer
Charging DHW+swi pool	Charging DHW+swi pool

End user (Eu)	Commissioning, Engineer (menu Status)
Charging buffer+swi pool	Charging buffer+swi pool
Charging DHW	Charging DHW
Charging buffer	Charging buffer
Charging swimming pool	Charging swimming pool
Radiation insufficient	Min charg temp not reached
	Temp diff insufficient
	Radiation insufficient

Tab.32 Status table solid fuel boiler

The following messages are possible under **Solid fuel boiler**:

End user (Eu)	Commissioning, Engineer (menu Status)
Manual control active	Manual control active
Fault	Fault
Overtemp prot active	Overtemp prot active
Released	Locked, manual
	Locked, automatic
Min limitation active	Min limitation
	Min limitation, low-fire
	Min limitation active
In operation for HC	Protective start
	Protective start, low-fire
	Return limitation
	Return limitation, low-fire
	In operation for HC
In part load op for HC	In part load op for HC
In operation for DHW	In operation for DHW
In part load op for DHW	In part load op for DHW
In op for HC, DHW	In op for HC, DHW
In part load op for HC, DHW	In part load op for HC, DHW
Overrun active	Overrun active
In operation	In operation
Assisted firing active	Assisted firing active
Released	Released
Frost protection active	Frost prot plant active
	Boiler frost prot active
Off	Off

Tab.33 Status table burners

The following messages are possible under **Burner**:

End user (Eu)	Commissioning, Engineer (menu Status)
Lockout position	Lockout position
Start prevention	Start prevention
In operation	In operation
Startup	Safety time
	Prepurge
	Startup
	Postpurge
	Shutdown

End user (Eu)	Commissioning, Engineer (menu Status)
	Home run
Standby	Standby

Tab.34 State table buffer storage tank

The following messages are possible under **Buffer storage tank**:

End user (Eu)	Commissioning, Engineer (menu Status)
Hot	Hot
Frost protection active	Frost protection active
Charg el imm heater	El charg, emergency mode
	El charg, source protection
	Electric charging defrost
	Electric charging, forced
	Electric charging, substitute
Charging restricted	Charging locked
	Restricted, DHW priority
Charging active	Forced charging active
	Partial charging active
Recooling active	Recooling via collector
	Recooling via DHW/HCs
Charged	Charged, max st tank temp
	Charged, max charging temp
	Charged, forced temp
	Charged, required temp
	Part charged, required temp
	Charged, min charging temp
Cold	Cold
No request	No request

Tab.35 Status table swimming pool

The following messages are possible under **Swimming pool**:

End user (Eu)	Commissioning, Engineer (menu Status)
Manual control active	Manual control active
Fault	Fault
Heating mode restricted	Heating mode source
Heated, max swi pool temp	Heated, max swi pool temp
Heated	Heated, setpoint solar
	Heated, setpoint source
Heating mode	Heating mode solar off
	Heating mode source off
Cold	Cold

9.2.25 Diagnostics cascade/heat generation/consumers

■ Diagnostics cascade/heat generation/consumers (8100-9058)

Displays of different setpoint and actual values, relay switching statuses and counter statuses for diagnostics purposes.

■ Gas energy

There are 6 energy meters available, comprising the estimated gas energy used with the aid of the fan speed and a linear approximation of the actual burner output. The energy meters must be switched on and off using prog.no. 2550. The results can be corrected under prog.no. 2551.

- 2 overall meters can be reset on the engineer level:
 - Prog.no. 8378: Total gas energy heating
 - Prog.no. 8379: Total gas energy DHW
- The end consumer can reset 2 meters:
 - Prog.no. 8381: Gas energy heating
 - Prog.no. 8382: Gas energy DHW



Important

Prog.no. 8380 and 8383 are the result of adding the previous parameters.

9.2.26 Burner control

■ Prepurge time (9500)

Pre-venting time.



Caution

This parameter must only be changed by a heating specialist!

■ Required output prepurging (9504)

Nominal output fan speed during preventing.

■ Required output ignition (9512)

Nominal output fan speed during ignition.

■ Required output LF (9524)

Nominal output fan speed under boiler in part load.



Important

If you change this value, please note that prog.no. 2452 (Controller delay fan output) is always higher.



For more information, see

Controller delay fan output (2452), page 102

■ Required output HF (9529)

Nominal output fan speed under boiler in HF

■ Postpurge time (9540)

After-venting time.



Caution

This parameter must only be changed by a heating specialist!

■ Fan output/speed slope (9626) and Fan output/speed Y-section (9627)

The speed of the fan can be adjusted with this. This is important for complex installations or change to LPG.

- Prog 9626 corresponds to the slope of the fan curve
- Prog 9627 corresponds to the displacement of the fan curve in Y-direction

9.2.27 Info option

Different information values are displayed depending on the operating conditions. In addition, information about the status is displayed.



For more information, see
Status, page 132
State, page 132

10 Maintenance

10.1 General

10.1.1 General instructions

According to EU Directive 2002/91/EC (Energy Performance of Buildings), Article 8, boilers with a rated output from 20 to 100 kW should be regularly inspected.

In heating and air conditioning systems, a regular inspection and maintenance as required by qualified personnel contribute to correct operation according to the product specification, and therefore to ensuring high efficiency and low environmental pollution in the long term.



Danger of electric shock

Before any work, switch off the mains supply to the boiler!

Before removing parts of the casing, the boiler has to be de-energised.

Work under voltage (removed casing) may only be carried out by a trained electrician.



Danger

Risk of poisoning.

Never use condensate water as drinking water!

- Condensate is not suitable for consumption by people or animals.
- Do not let the skin come into contact with condensate.
- Suitable protective clothing must be worn during maintenance work.



Caution

Only a qualified professional is authorised to clean the inside of the boiler.

Cleaning of heating surfaces and burner should be carried out by the approved installer. Before beginning work, the gas tap and the shut-off valves of the heating water should be closed.

10.1.2 Inspection and service as required



Important

We recommend having the Paramount inspected annually.

If the need for maintenance work is found during inspection, this should be carried out according to need.

Maintenance work includes:

- Clean Paramount outside.
- Checking the burner for contamination and, possibly, cleaning and servicing.
- Cleaning burner areas and heating surfaces
- Replacing wear parts (see *Spare parts list*).



Caution

Only genuine spare parts may be used.

- Checking connection and seal locations of water filled parts.
- Check safety valves for correct function.
- Check operating pressure and top up the water if necessary.
- Vent the heating system.
- Put the gravity lock back into operating position.
- End control and documentation of service work performed.

10.1.3 Lifetime of safety-relevant components

Safety-relevant components (e.g. gas valves) have a limited lifetime that mainly depends on the operating years and the operating cycles. The remaining lifetime of individual safety-relevant components can be determined as part of maintenance work carried out by an approved installer. If the lifetime Potterton Commercial in accordance with the following table is exceeded, recommends replacing the relevant components.

Safety-relevant components	Design-related rated lifetime	
	Operating cycles	Years
Gas pressure monitor Paramount 30 - 115	50,000	10
Boiler control	250,000	10
Gas valve Paramount 5060	500,000	10
Paramount 80 - 115	200,000	10



Important

The number of operating cycles can be read under *Start counter 1st stage* (prog. no. 8331) in the menu item *Diagnostics heat generation*.

10.1.4 Protection against contact



Danger of electric shock

Danger to life due by missing shock-proof protection.

To ensure shock-proof protection, all parts of the boiler to be screwed on – the casing parts in particular – must be screwed on correctly after work has been completed.

10.1.5 Approved detergents

Cleaned heat exchangers improve heat transfer and save energy. The following detergents have been tested and approved by Potterton Commercial for cleaning heat exchangers:

- Sanit Care aluminium-silicum heat exchanger special cleaner
- Sotin 240 boiler cleaner



Danger

Cleaning agents for aluminium heat exchangers are irritants and/or corrosive.

Before starting work the corresponding security and safety measures of the manufacturer must be observed. In addition the instructions for use and transport printed on the packaging and container must be observed.



See

The Potterton Commercial maintenance instructions must be observed.



Important

The safety data sheets for the detergents listed are included with the product or are available from the respective manufacturers.



Caution

During application of the detergent only the heat exchanger on the flue gas side may be treated. No detergent residue may remain on the boiler components, the cable plugs or casing, since this can otherwise lead to corrosion and appliance malfunction. Residues sprayed by mistake must be cleaned off immediately using a damp cloth.

10.1.6 Unhooking the control panel

Fig.35 Unhooking the control panel

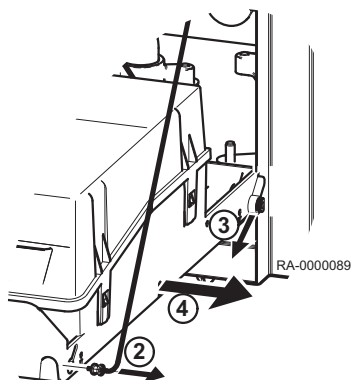

To make assembly e.g. installation of a charging pump easier, the control panel can be unhooked.

1. Fold the control panel (KSF) down.
2. Unhook the straps on the left and right of the KSF.



Caution

Hold the KSF to make sure it does not flop forwards.

3. The KSF can be pulled out to the right.
4. Unhook the complete KSF to the right.



Important

Make sure that the KSF can be set down safely in an appropriate place.

10.1.7 At the end of the maintenance work



Danger

Risk to life due to explosion, fire or escaping flue gas.

- Before commissioning the boiler, the parts of the system through which fuel and flue gas flow must be checked for leaks.
- If there are any leaks in the pipelines, the seals must be replaced. If there are any leaks due to defective components, the components in question must be replaced.

- After finishing the cleaning work, re-install the heat exchanger and burner.
- Check the nominal heat load and exhaust gas values.

10.2 Maintenance messages

10.2.1 Maintenance code table

Servicing code	Maintenance description
1:Burner hours run	Burner operating hours exceeded
2:Number of burner starts	Burner starts exceeded
3:Maintenance interval	Maintenance interval exceeded

10.2.2 Operating phases of the Control Centre LMS

The operating phases are displayed after the **information key** has been pressed.

Phase number		
Display	Operating state	Description of function
STY	Standby (no heat demands)	Burner on stand-by
THL1	Fan start-up	Self-test for burner start and fan start-up
THL1A		
TV	Pre-purging time	Pre-purging, fan deceleration time to starting load speed
TBRE	Waiting time	Internal safety tests
TW1		
TW2		
VDE	Ignition phase	Ignition and start of safety time for flame formation, ionisation current build-up

Phase number		
Display	Operating state	Description of function
TSA1	Safety time constant	Flame monitoring with ignition
TSA2	Safety time variable	Flame monitoring without ignition
TI	Interval time	Flame stabilisation
MOD	Modulating mode	Operating burner
THL2	Subsequent ventilation with last operating fan speed	Fan continues to run
THL2A	Subsequent ventilation with pre-purging fan speed	Fan continues to run
TNB	Burner shut-off delay	Permitted burner run-on time
TNN	Overrun time	Permitted fan run-on time
STV	Start prevention	No internal or external release exists (e.g. no water pressure, lack of gas)
SAF	Safety switch-off	
STOE	Fault position	The current fault mode is displayed.



For more information, see
Fault code table, page 147

10.3 Standard inspection and maintenance operations

10.3.1 Clean siphon

The condensate siphon should be cleaned every year.

1. Loosen the upper screwed fitting on the siphon.
2. Pull the siphon down and off.
3. Remove the siphon completely from the Paramount together with the hose.
4. Dismantle the siphon and flush it through with clean water.
5. Installation of the siphon is done in reverse order.



Important

At the same time, the exhaust gas collecting tray should be checked for soiling and should be cleaned (rinsed) if necessary.

Fig.36 Electrodes

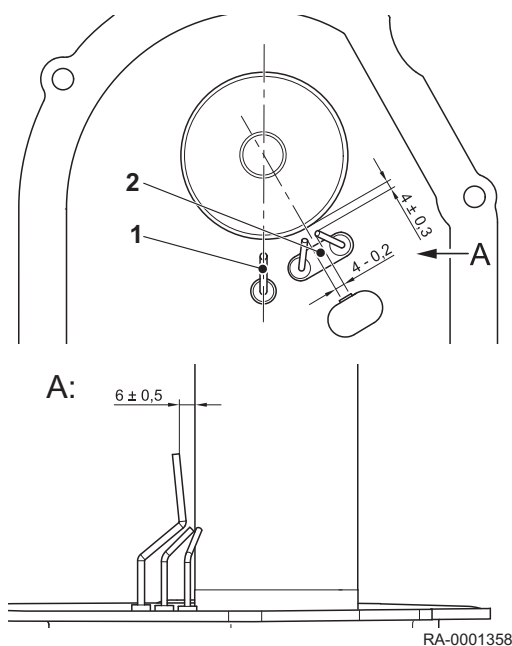

10.3.2 Check electrodes

Ionisation electrode (1)



Danger of electric shock

Danger to life due to high voltage.
Do not touch plug contacts during the ignition process.



Caution

The wire of the ionization electrode must not be bent since it can break easily.

The ionization electrode must always be in contact with the flame.

The distance from the ionization electrode to the blast tube must be maintained in accordance with Fig. When replacing the ionization electrode, check its distance to the burner and correct if required. To do this, loosen the burner on the mixing tube and move it until the distance corresponds to the required dimension.

For measurement of the ionisation current, pull plug from the gas-firing automaton and connect ammeter between plug and electrode.

Ignition electrodes (2)

To ensure that the Paramount unit ignites reliably and quietly, the installation position and the spacing between the ignition electrodes shown in the illustration must be complied with.

10.4 Specific maintenance operations

10.4.1 Replacing air vent



Caution

Only genuine spare parts may be used.



Caution

Drain off boiler water.
The boiler water has to be drained before the air vent is removed, otherwise water will leak out.

A defective air vent may only be replaced by a genuine spare part; this guarantees optimum venting.

10.4.2 Removing and installing the gas burner



Caution

Close the gas valve before carrying out any work.

Remove the gas burner before cleaning the heating surfaces.

Fig.37 Removing the gas burner
Paramount 30/40

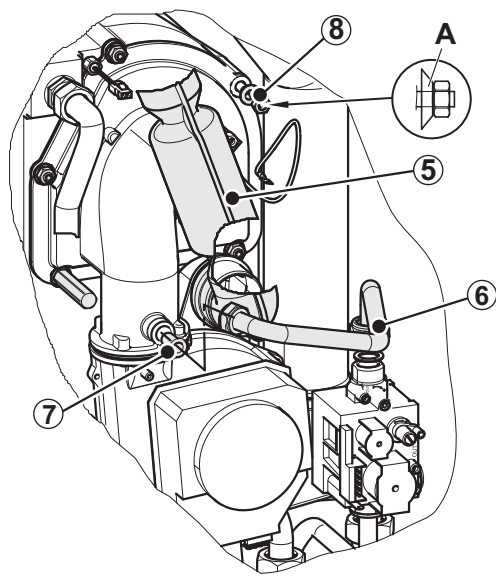

Paramount 50/60

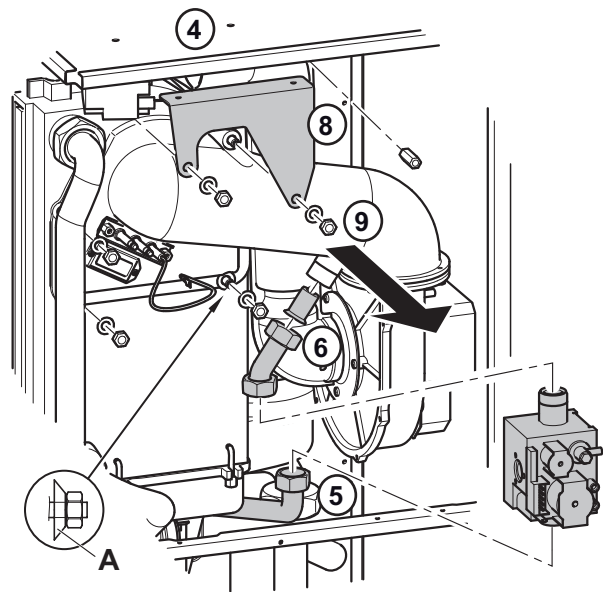

Paramount 80

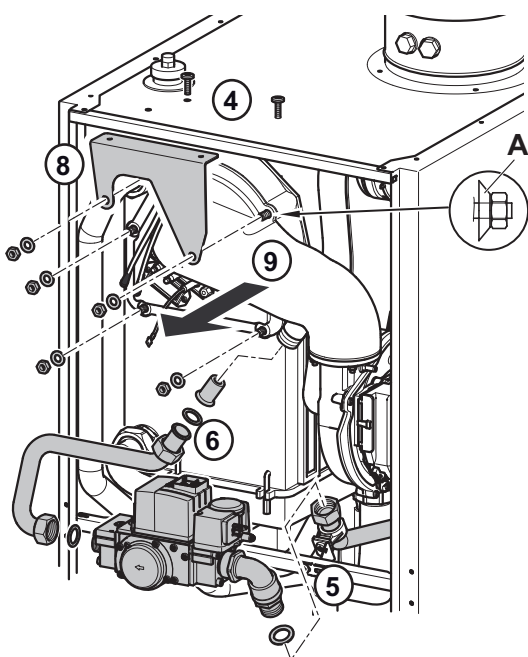

Paramount 95/115

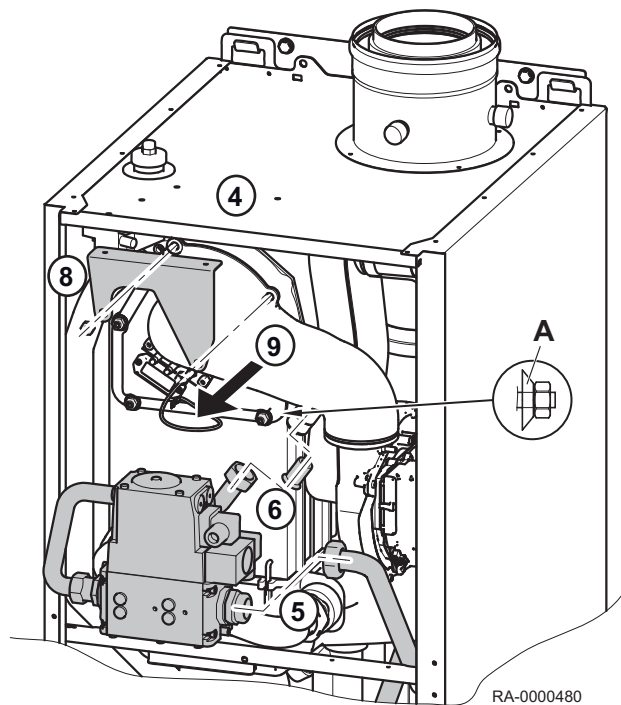

A Elastic washer

1. Disconnect the electrical connection cables to the fan at the coupler.
2. Pull the air hose off the fan.
3. Pull the connector off the electrodes.
4. Undo the attachment screw for the air intake silencer at the top of the Paramount.
5. Remove the air intake silencer.
6. Loosen the screw connections of the gas connection pipe at the mixing tube and the gas valve.
7. Remove the gas connection pipe and the gas nozzle.
8. Loosen the 5 fastening screws at the mixing tube/heat exchanger.
9. Remove the bracket.
10. Pull the burner together with mixing tube and fan forwards and out.

11. Pull out the burner together with mixing duct, fan and exhaust gas muffler to the front
12. Clean the burner pipe with a soft brush.
13. Use a new seal when installing the gas burner.

**Caution**

Use new seals
When re-fitting, new seals should be used, particularly for the gas connecting pipe.

**Caution**

Make sure the spring disc is in the right position.
Make sure the spring disc is in the right position during installation.
Predetermined torque: 9 Nm.

**Caution**

After heating up the burner for the first time, you must check the torque again.

10.4.3 Removing gas valve

1. Remove the electrical connections from the gas valve.
2. Loosen both threaded connections on the gas valve and remove the gas valve.

**Important**

Use new seals when installing the gas valve.

10.4.4 Removing the heat exchanger

Carry out the following steps if the heat exchanger has to be completely removed.

**Important**

- The burner must have been removed.
- To make removal easier, the gas valve should also have been removed.

Fig.38 Removing the heat exchanger

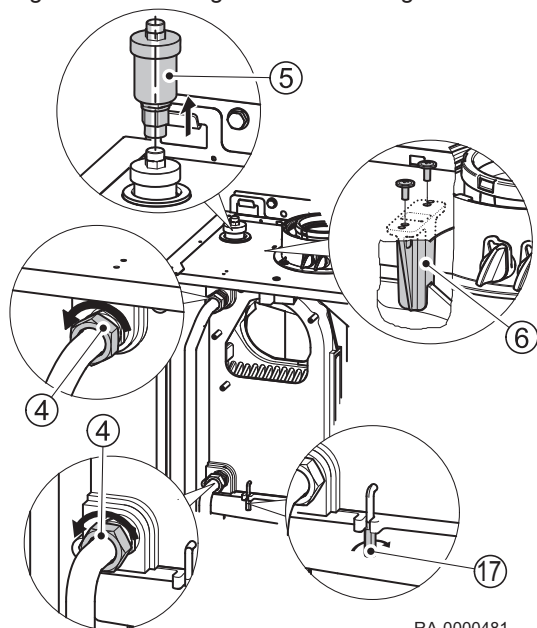

1. Close disconnecter valves in flow and return.
2. Drain off the boiler water.
3. Pull the plugs from boiler sensors (flow and return).
4. Loosen the screw connectors of flow and return on the heat exchanger (flat seal).
5. Remove the air vent.
6. Paramount3040 Remove the plastic retainer from the top of the heat exchanger. For this, remove 2 screws from the casing cover
7. Take the holding clips off.
8. Lift the heat exchanger off the flue gas collector and lift it out.
9. Pull the cable off the water pressure monitor.
10. Undo the screwed connector at the pump replacement pipe and remove the pipe or pump.
11. Paramount5080 Remove the return pipe.
12. Pull the plug off the gas valve, loosen and remove the gas valve.
13. Paramount95115 Remove the connection line between the heat exchanger and the collector box.
14. Remove the retaining ring and push the slide coupling on the flue pipe upwards.
15. Paramount5080 Remove the gas pipe.
16. Remove the siphon.
17. Loosen nuts at the collecting tray, remove the clip and remove the collecting tray.
18. Loosen the nuts for the support plate on the back wall.
19. Lift and remove the heat exchanger with the support plate from the back wall and take out.

20. Clean the heat exchanger in accordance with the maintenance instructions.



For more information, see

Removing and installing the gas burner, page 143

Removing gas valve, page 145

11 Troubleshooting

11.1 Error codes

11.1.1 Fault code table

The following is an extract from the fault code table. If other fault codes are displayed, please inform the installer.

Fault code	Error description	Explanations/causes
0	No fault	
10	Outside temp sensor fault	Check connection or outside temp sensor, emergency operation
20	Boiler temperature 1 sensor fault	Check connection, inform heating specialist ⁽¹⁾
25	Boiler temperature solid fuel sensor fault	
26	Boiler temperature solid fuel sensor fault	
28	Boiler temperature solid fuel sensor fault	
30	Flow temperature 1 sensor fault	
32	Flow temperature 2 sensor fault	Check connection, inform heating specialist ⁽¹⁾
38	Boiler temperature solid fuel sensor fault	
40	Return temperature 1 sensor fault	Check connection, inform heating specialist ⁽¹⁾
46	Boiler temperature solid fuel sensor fault	
47	Common return temp sensor fault	
50	DHW temperature 1 sensor fault	Check connection, inform heating specialist, emergency operation ¹⁾
52	DHW temperature 2 sensor fault	Check connection, inform heating specialist ⁽¹⁾
54	Flow temperature DHW sensor fault	
57	Drinking water circulation temperature sensor fault	
60	Room temperature 1 sensor fault	
65	Room temperature 2 sensor fault	
68	Room temperature 3 sensor fault	
70	Storage tank temp 1 (top) sensor fault	
71	Storage tank temp 2 (bottom) sensor fault	
72	Storage tank temp 3 (middle) sensor fault	
73	Collector temperature 1 sensor fault	
81	LPB short-circuit or no bus power supply	
82	LPB address collision	Check addresses of connected control modules
83	BSB wire short-circuit	Check connection of the room units
84	BSB address collision	2 room devices have the same assignment (prog.no. 42)
85	BSB wireless commissioning fault	
91	EEPROM fault: information of locking mechanism	Internal fault LMS, process sensor, replace LMS, heating specialist
98	Expansion module 1 fault (collective fault)	
99	Expansion module 2 fault (collective fault)	
100	Two time masters (LPB)	Check time master
102	Clock time master without backup	
105	Maintenance message	See maintenance code (press information button once) for detailed information
109	Boiler temperature monitoring	
110	Safety temperature limiter lockout	No heat removal, faulty sensor, STB/interruption, possible short circuit in the gas valve ⁽²⁾ , internal fuse faulty; allow device to cool down and carry out reset; if the fault occurs several times inform the installer ⁽³⁾
111	Temperature monitor switching off	No heat supply; pump defect, radiator valves closed ¹⁾

Fault code	Error description	Explanations/causes
119	Fault water pressure	Check water pressure or fill in water ¹⁾
121	Flow temperature 1 (Heating circuit 1) monitoring	
122	Flow temperature 2 (Heating circuit 2) monitoring	
126	DHW charging monitoring	
127	Legionnaire's disease germs temperature not reached	
128	Flame failure during operation	
132	Gas pressure Monitor fault	Lack of gas, contact GW opened, external temperature monitor
133	No flame during the safety time	Reset, if the fault re-occurs several times contact installer, lack of gas, polarity of mains connection, safety period, check ignition electrode and ionization current ^{1) 3)}
146	Configuration fault common message	
151	Internal fault	Check parameters (see adjustment table installer and/or call-up values), unlock LMS, replace LMS, installer ^{1) 3)}
152	Parameterization fault	
160	Fan fault	Fan possibly defective, speed threshold set wrongly ³⁾
162	Air pressure monitor does not close	
171	Alarm contact H1 or H4 activated	
172	Alarm contact H2 (EM1, EM2 or EM3) or H5 activated	
178	Temperature monitor heating circuit 1	
179	Temperature monitor heating circuit 2	
183	The device is in parameter setting mode	
217	Sensor fault	
218	Pressure monitoring	
241	Flow sensor solar sensor fault	
242	Return sensor solar sensor fault	
243	Swimming pool sensor fault	
260	Flow temperature 3 sensor fault	
270	Monitoring function	
317	Mains frequency outside of valid range	
320	DHW charging temp sensor fault	
322	Water pressure too high	Check water pressure and drain water if necessary ¹⁾
323	Water pressure too low	Check water pressure and top up with water if necessary ¹⁾
324	BX same sensors	
325	BX / extension module same sensors	
326	BX / mixer group same sensors	
327	Extension module same function	
328	Mixer group same function	
329	Extension module / mixer group same function	
330	Sensor BX1 no function	
331	Sensor BX2 no function	
332	Sensor BX3 no function	
335	Sensor BX21 no function (EM1, EM2 or EM3)	
336	Sensor BX22 no function (EM1, EM2 or EM3)	
339	Collector pump Q5 missing	
341	Collector sensor B6 missing	
342	Solar DHW sensor B31 missing	
343	Solar interconnection missing	
344	Solar actuator buffer K8 missing	
345	Solar actuator swimming pool K18 missing	
346	Solid fuel boiler pump Q10 missing	

Fault code	Error description	Explanations/causes
347	Solid fuel boil comp sensor missing	
348	Solid fuel boiler address error	
349	Storage buffer return valve Y15 missing	
350	Storage buffer address error	
351	Primary controller/supply pump address error	
352	Low-loss header address error	
353	Common flow sensor B10 missing	
371	Flow temperature 3 (Heating circuit 3) monitoring	
372	Temperature monitor HK3	
373	Expansion module 3 fault (collective fault)	
378	Repetition counter internal fault expired	
382	Repetition counter fan fault expired	
384	External light	
385	Mains undervoltage	
386	Fan speed has left valid range	
387	Air pressure switch fault	
426	Feedback flue damper	
427	Configuration flue damper	
432	Functional earth X17 not connected	
<p>(1) Switch off, start prevention, re-start after elimination of fault (2) Check parameter in accordance with table Check the installer adjustment table and program to the basic settings or query internal LMS SW diagnosis code and correct the corresponding parameter faults according to fault specification (3) switch-off and locking; can only be unlocked by reset</p>		

11.2 Fault finding

11.2.1 Fault switch-off

Safety switch-off in case of flame failure during operation.

After every safety switch-off a new ignition attempt is carried out as per program. If this does not result in flame formation a fault switch-off occurs.

In case of fault switch-off, the reset button on the control panel should be pressed.

In case of operation disturbances (bell symbol in the display), the digit in the display on the operating panel indicates the cause of the disturbance (see fault code table).

Burner does not start:

- No voltage at the control and regulating centre
- No "burner ON" signal from the heating circuit control (see *Fault code table*)
- Gas tap closed
- No ignition

Burner goes into fault mode (no flame formation):

- No ignition
- Ionization electrode has ground connection
- Ionization electrode is not connected
- No gas
- Gas pressure too low

In spite of flame formation the burner goes into fault mode after expiration of the safety time:

- Ionization electrode defective or soiled
- Ionization electrode does not penetrate the flame
- Ionization electrode is not connected

- Gas pressure not stable

12 Disposal

12.1 Disposal/recycling

12.1.1 Packaging

As part of the packaging regulations, Potterton Commercial provides local disposal facilities for the specialist company to ensure correct recycling of all the packaging. In order to protect the environment, the packaging is 100% recyclable.

**See**

Please follow the legal requirements applicable to disposal in your country.

12.1.2 Appliance disposal

The appliance can be returned to Potterton Commercial for disposal via a specialist company. The manufacturer undertakes to recycle the appliance correctly.

**Important**

The appliance is recycled by a disposal company. If possible, the materials, especially the plastics, are identified. This enables correct sorting for recycling.

13 Appendix

13.1 Declaration of conformity

13.1.1 Declaration of conformity



EU-Declaration of Conformity No. 2018/069

Product	Gas Condensing Boiler
Trade Mark	Paramount five
Product-ID Nummer	CE-0085 BL 0514
Type, Model	Paramount five 30, Paramount five 40, Paramount five 50, Paramount five 60, Paramount five 80, Paramount five 95, Paramount five 115
EU Directives EU Regulations	(EU)2016/426, 92/42/EG, 2009/125/EG, (EU)2017/1369, (EU)811/2013, (EU)813/2013, 2014/30/EU, 2014/35/EU
Standards	DIN EN 15502-1:2015-10; DIN EN 15502-2-1:2017-09; EN 13203-2:2015-08 DIN EN 60335-1:2012-10; EN 60335-1:2012 DIN EN 60335-1 Ber.1:2014-04; EN 60335-1:2012/AC:2014 EN 60335-1:2012/A11:2014 DIN EN 60335-2-102:2010-07; EN 60335-2-102:2006+A1:2010 DIN EN 62233:2008-11; EN 62233:2008 DIN EN 62233 Ber.1:2009-04; EN 62233 Ber.1:2008 DIN EN 55014-1:2012-05; EN 55014-1:2006 + A1:2009 + A2:2011 DIN EN 55022:2011-12; EN 55022:2010 DIN EN 61000-3-2:2010-03; EN 61000-3-2:2006 + A1:2009 + A2:2009 DIN EN 61000-3-3:2014-03; EN 61000-3-3:2013 DIN EN 55014-2:2009-06; EN 55014-2:1997 + A1:2001 + A2:2008 Requirements of the category II
EG-Type Examination	TÜV Rheinland Energie GmbH Am Grauen Stein 51105 Köln
Surveillance Procedure	Module D EG Gas Appliance Regulation (EU)2016/426 DVGW CERT GmbH D-53123 Bonn

The producer states the following:

The above named products fulfil the requirements of the directives, regulations and standards. They are identical with the prototype examined. The production process follows the guidelines of the surveillance procedure. The above named products are only for installations in hot water heating systems. The installer has to assure that the directives for installation and operation are being followed.

ppa. S. Harms

Technical Director
-AUGUST BRÖTJE GmbH-

i.V. U. Patzke

Test Laboratory Manager and
Delegate for Documentation
-AUGUST BRÖTJE GmbH-

Potterton Commercial
Innovation House
3 Oaklands Business Centre
Oaklands Park
Wokingham
Berkshire
RG412FD
Telephone: +44 (0345) 070 1057
www.pottertoncommercial.co.uk

21.04.2018

Index

- A**
- Additives 30
 - Antifreeze agent 32
 - Assembling the elements 43
 - Automatic day heating limit 58
 - Automatic operation 58
 - Automatic summer/winter changeover 58
- B**
- Burner cleaning 139
- C**
- Cable lengths 47
 - Changing settings 56
 - Check electrodes 143
 - Check ignition electrodes 143
 - Check ionization electrode 143
 - Check tightness 39,40,141
 - Chimney sweep function 61
 - Cleaning and inspection openings 46
 - Cleaning of the burner 139
 - Cold water 57
 - Combustion air supply 42
 - Combustion supply air 35
 - Comfort setpoint 59
 - Condensate 39
 - Condensate connection 18,19,20,21
 - Contaminated chimneys 42
 - Continuous mode 58
 - Controller stop function 52
 - Corrosion damage 42
- D**
- Disconnecter valve 38,58
 - Disposal 151
 - Domestic water mode 58
 - Domestic water temperature 95
- E**
- ECO function 26
 - Emergency operation 61
 - Emergency switch 47
 - ESC key 25
- F**
- Factory setting 85,121
 - Fault 149
 - Fault code table 147
 - Fault message 26
 - Filter 38
 - First time commissioning 51
 - Flat seal screw connections 38
 - Frost protection setpoint 26,58
- G**
- Gas connection 18,19,20,21,39
 - Gas filter 39
 - Gas tap 58
 - Gravity lock 139
- H**
- Heating emergency switch 58
 - Heating mode 58
 - Heating water quality 29
- I**
- INFO 26
 - Information key 25
 - Installation room 35
 - Introducing into a shaft 44
 - IP rating 36,48
- K**
- Keys 25
 - ESC key 25
 - Information key 25
 - OK key 25
- L**
- Language 50
 - Legionella function 59
 - Liquid gas below ground level 9
- M**
- Mains isolator 47
 - Maintenance 139
 - Maintenance message 26
 - Manual adjustment of burner output 52
 - Manual control 61,126
- O**
- OK key 25
 - ON/OFF switch 25
 - Operating mode keys 25
 - Domestic water mode 25
 - Heating mode 25
 - Operating phases 141
 - Optimum start and stop control 92
 - Outdoor temperature sensor 48
- P**
- Packaging 151
 - Pressure gauge 25
 - Protection mode 58
 - Pump setting 60
- Q**
- Quick reduction 91
- R**
- Recycling 151
 - Reduced setpoint 59
 - Reduced setpoint increase 92
 - Regulations 13
 - Resistance values 16
 - Room temperature 59
 - Comfort setpoint 59
 - Reduced setpoint 59
- S**
- Safety valve 21
 - Safety valve 18,19,38,139
 - Setting pump 60
 - Setting the curve 88
 - Setting the heating curve 88
 - Shortening of the pipes 43
 - Shut-off valve 39
 - Software version 15
 - Standards 13

Index

Summer/winter heating limit 89

Topping up water 139

T

Tip on energy-saving; circulating pump 97

© Copyright

All technical and technological information contained in these technical instructions, as well as any drawings and technical descriptions supplied, remain our property and shall not be multiplied without our prior consent in writing. Subject to alterations.

Potterton Commercial Part of Baxi Heating UK Ltd | Innovation House
Oaklands Business Centre Oaklands Park | Wokingham RG41 2FD
Phone 0345 070 1055 | www.potertoncommercial.co.uk

