

User Guide

Condensing System Boiler

Ultra System

12 - 15 - 18 - 24 - 28

Please keep these instructions in a safe place.
If you move house, please hand them over to the next occupier.

Model Range

Potterton Ultra 12 System

G.C.N°41-592-71

Potterton Ultra 15 System

G.C.N°41-592-72

Potterton Ultra 18 System

G.C.N°41-592-73

Potterton Ultra 24 System

G.C.N°41-592-74

Potterton Ultra 28 System

G.C.N°41-592-75

Warning

This boiler can be used by children aged 8 years and above and by persons with reduced physical, sensory or mental capabilities or lack of experience and knowledge when they have been given supervision or instruction concerning the safe use of the device and understand the resulting risks. Children must not be allowed to play with the appliance. Cleaning and user maintenance must not be carried out by children without supervision.

The Benchmark Scheme

Baxi Heating UK Ltd is a licensed member of the Benchmark Scheme which aims to improve the standards of installation and commissioning of domestic heating and hot water systems in the UK and to encourage regular servicing to optimise safety, efficiency and performance.

Benchmark is managed and promoted by the Heating and Hotwater Industry Council. For more information visit www.centralheating.co.uk

© Baxi Heating UK Ltd 2017 All rights reserved. No part of this publication may be reproduced or transmitted in any form or by any means, or stored in any retrieval system of any nature (including in any database), in each case whether electronic, mechanical, recording or otherwise, without the prior written permission of the copyright owner, except for permitted fair dealing under Copyrights, Designs and Patents Act 1988.

Applications for the copyright owner's permission to reproduce or make other use of any part of this publication should be made, giving details of the proposed use, to the following address:

The Company Secretary, Baxi Heating UK Limited,
Brooks House, Coventry Road, Warwick. CV34 4LL

Full acknowledgement of author and source must be given.

WARNING: Any person who does any unauthorised act in relation to a copyright work may be liable to criminal prosecution and civil claims for damages.

IPX5D

CE 0085



WRAS APPROVED PRODUCT



ISO 9001
FM 00866

Contents

Section	Page
1.0 Quick Reference Guide	3
2.0 Troubleshooting	4
3.0 Temperature Adjustment & Care of the Boiler	6
4.0 Repressurising System & 'Service Due'	7
5.0 Clearances	8
6.0 Error Codes	9
7.0 Legislation	10
8.0 Warranty & Service	11
9.0 ErP Information	13
10.0 Emergency	16
11.0 Disposal	16

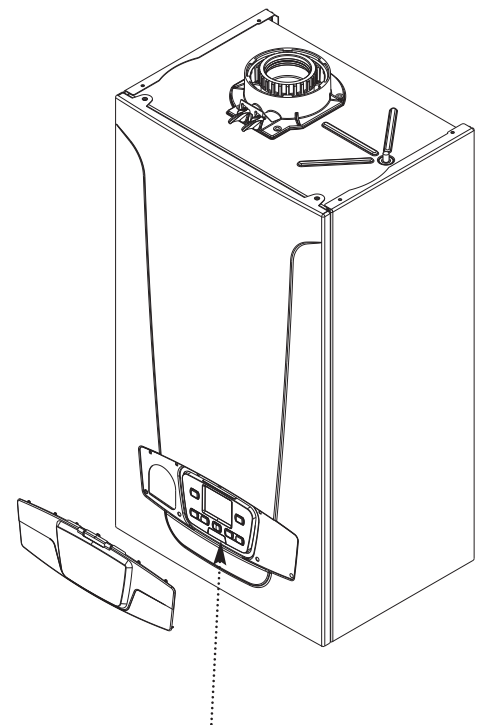

Boiler Controls - see opposite page for Operating Quick Reference Guide (Fascia Cover removed for clarity)

I.0 Quick Reference Guide

Key to Controls

 Standby - Reset - Esc

 Boiler Information View



 Increase Boiler Temperature Button

 Decrease Boiler Temperature Button

 Inactive Button

 Inactive Button

 On/Off Selector Button

When  is displayed (Boiler On) the boiler will respond to timed Heating or Hot Water demand. N.B. if only  is displayed the boiler will not operate !

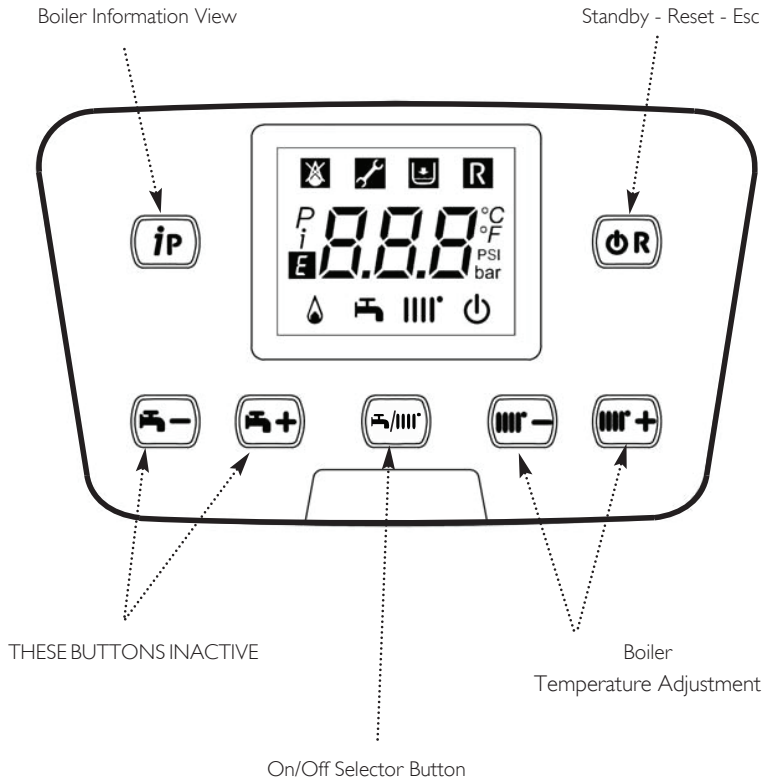



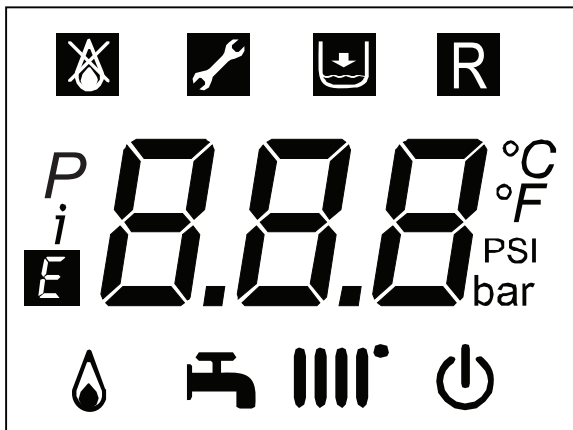





NOTE: When altering any settings it is necessary that the buttons are FIRMLY pressed for several seconds.



Display showing all available segment

Display Description

-  Domestic Hot Water and Central Heating OFF (frost protection still enabled)
-  Indicates errors that prevent burner from starting
-  Error - Not resettable by user
-  Water pressure too low
-  Indicates a resettable error
- P* Indicates navigation in programming mode (parameter)
- i* Indicates navigation in programming mode
-  Generic error
-  Burner lit
-  DHW request
-  Heating mode
- $^{\circ}\text{C}$ Units for temperature
- $^{\circ}\text{F}$ Units for temperature
- PSI Units for pressure
- bar Units for pressure
- Sd* Service due (when activated)

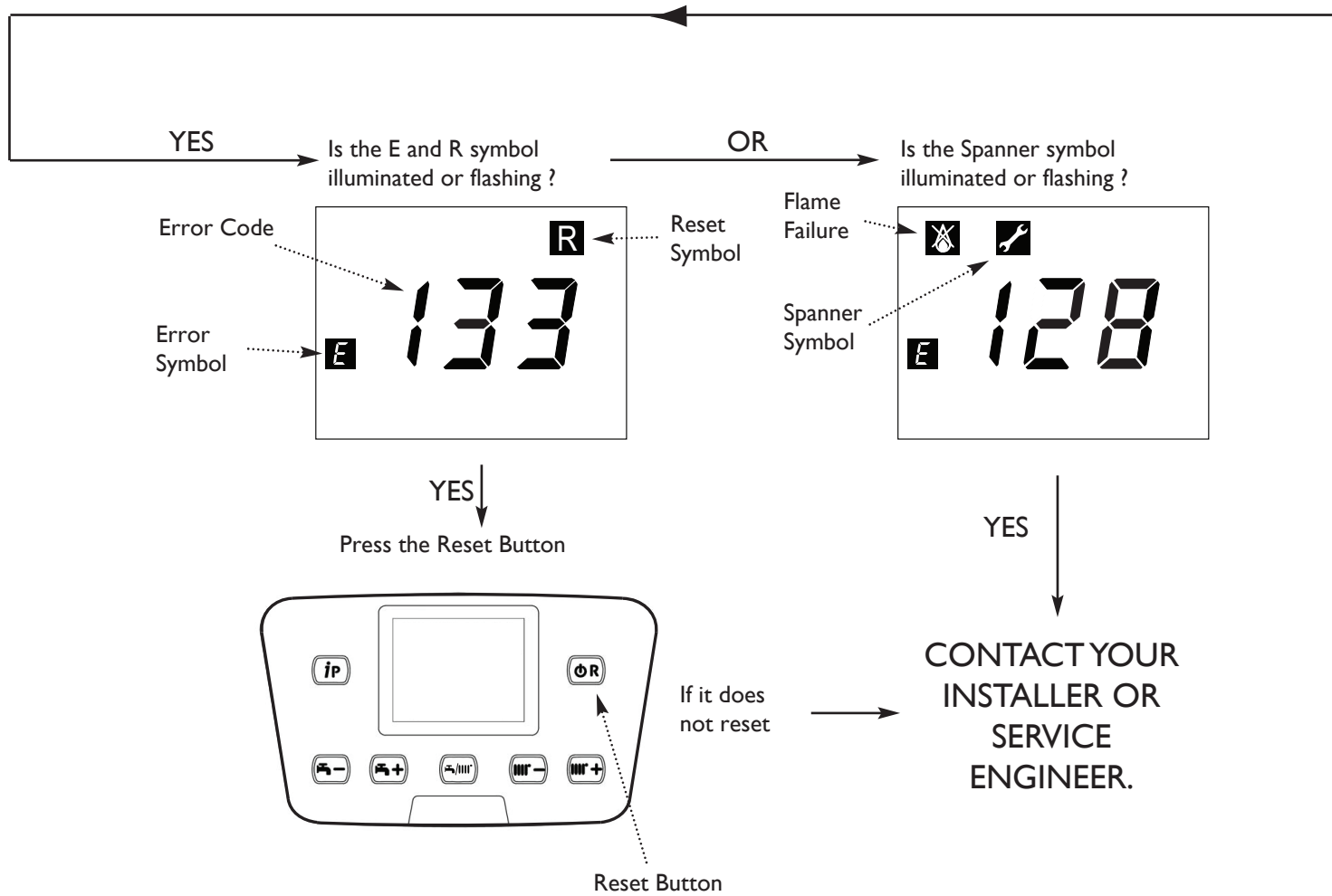
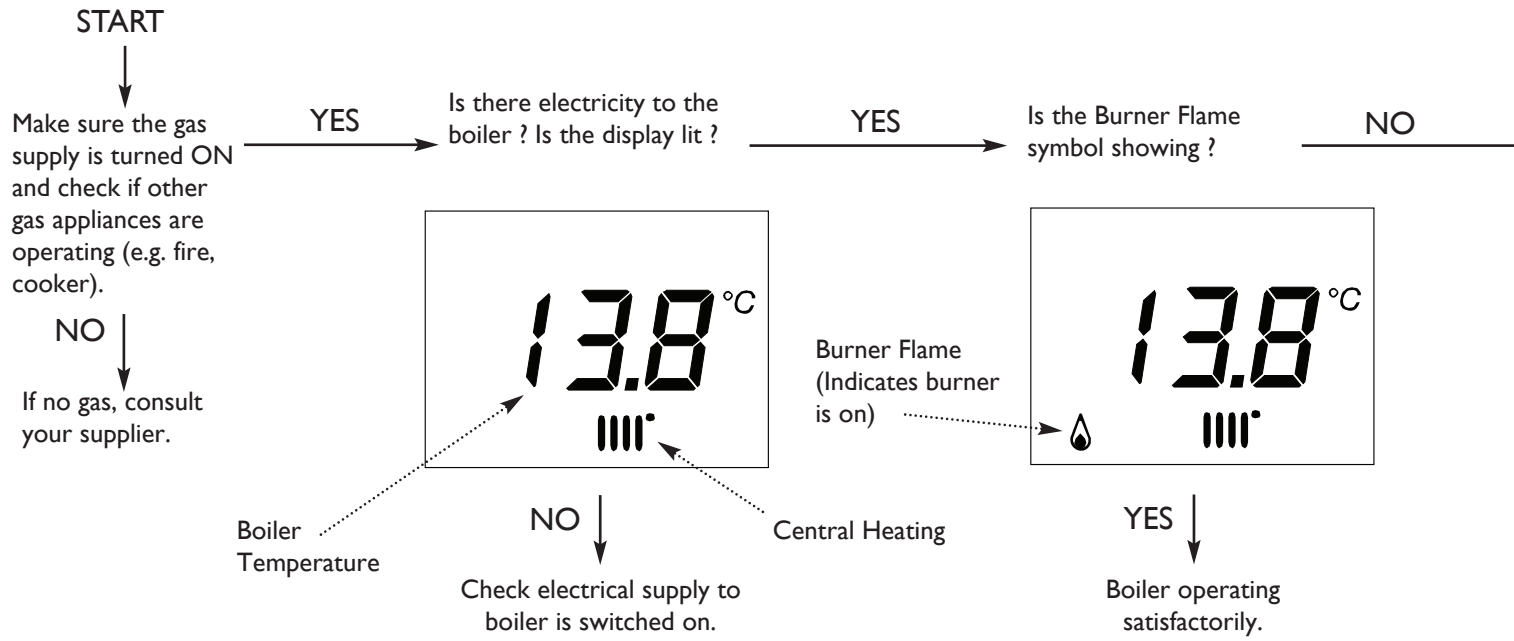

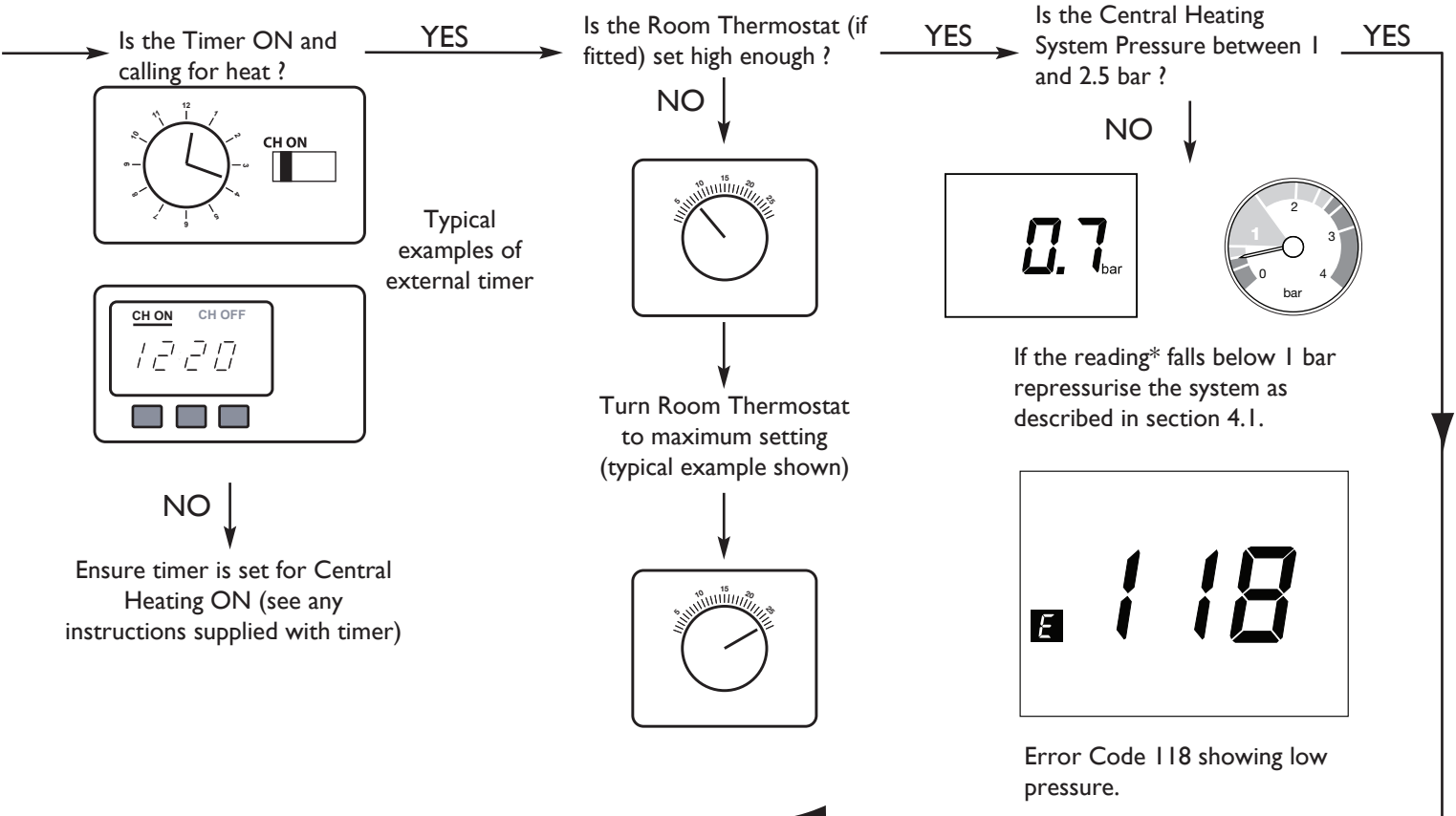

*To display the water pressure press **i P** 6 times. '05' will alternate with the system pressure.
 (NOTE: When the pump is running the gauge under the boiler may show a slightly different reading to the display)

If you don't know what you need to do to get the boiler to light, or need help with the system and controls, contact your installer as soon as possible

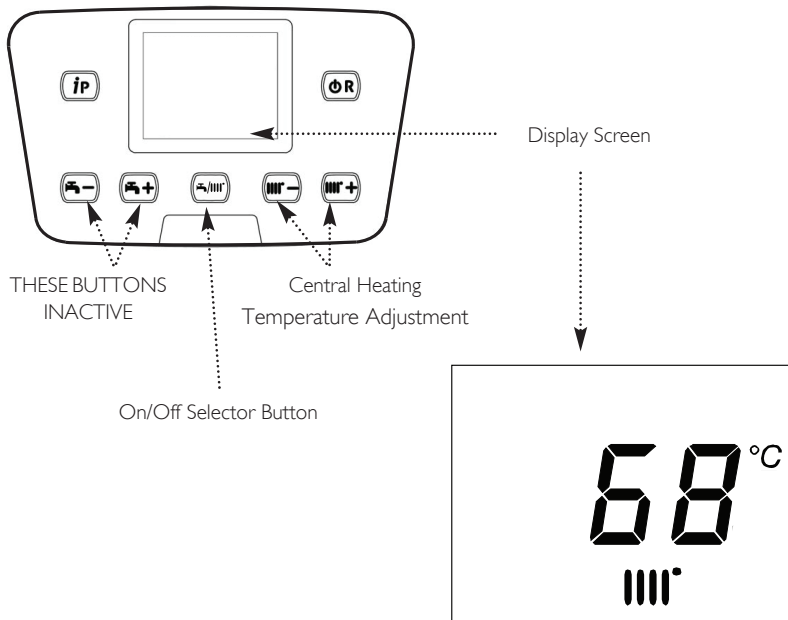

3.0 Temperature Adjustment & Care of the Boiler

3.1 To increase or decrease the boiler temperature

1. Press the () to increase the boiler temperature.
2. Press the () to decrease the boiler temperature.

NOTE: An overheat thermostat (NTC) is positioned in the heat exchanger which shuts down the appliance if the boiler temperature exceeds 100°C. Press button to re-establish normal operating conditions.

3.2 Boiler On Selector

1. Press the button until the Boiler On mode appears:-

3.3 Cleaning the Outercase

The painted panels should be wiped with a damp cloth and then dried completely. **DO NOT USE ABRASIVE CLEANING AGENTS.**

3.4 Boiler Frost Protection

1. The boiler incorporates an integral frost protection feature that will operate when the boiler is on, and also when in standby (displayed).
2. If the boiler temperature falls below 5° C, then the boiler will operate until the water temperature has been raised.
3. Further protection may be required for the system. Consult your installer for details.

3.5 Information Display

1. The table opposite shows information that can be displayed by pressing the *iP* button.
2. Press to return to the normal display.

The *iP* button can be pressed so that the display shows the following information:-

- 1 press - '00' alternates with Sub-Code (only when fault on boiler) or '000'
- 2 presses - '01' alternates with CH Flow Temperature
- 3 presses - '02' alternates with Outside Temperature (where Sensor fitted)
- 4 presses - '03' alternates with DHW Temperature
- 5 presses - '04' alternates with DHW Temperature
- 6 presses - '05' alternates with System Water Pressure
- 7 presses - '06' alternates with CH Return Temperature
- 8 presses - '07' alternates with Flue Temperature
- 9 presses - '08' alternates with Heat Exchanger Temperature

4.0 Repressurising System & 'Service Due'

4.1 Central Heating System Pressure

1. The water pressure in the central heating system is indicated by the pressure gauge and also can be viewed on the display when there is power to the boiler.

2. To display the water pressure press **IP** 6 times. '05' will alternate with the system pressure. (**NOTE:** When the pump is running the gauge under the boiler may show a slightly different reading to the display).

3. With the system cold and the boiler not operating the pressure should be at least 0.5 bar. During operation the pressure should not exceed 2.5 bar, and will normally be between 1.0 and 1.5 (Fig. 1).

4. A pressure of 3 or greater indicates a fault (E1 I7 displayed). The safety pressure relief valve will operate, at a pressure of 3 (Fig. 3). **It is important that your Installer or Service Engineer is contacted as soon as possible.**

5. The minimum pressure for correct operation is 0.5. If the pressure falls below 0.5, this may indicate a leak on the central heating system (Fig. 2). Error Code E1 I8 will be shown on the display.

4.2 To Re-Pressurise the System (Using Temporary Filling Loop)

1. It may be necessary to repressurise the system occasionally (when the water pressure falls below 0.7 bar). A filling device (filling loop) will be fitted on the system. This may be on the boiler itself or on pipework near to the boiler. Seek advice from your installer.

2. If the water pressure requires regular re-pressurising a fault or leak is indicated (see section 4.1). Seek advice from your installer.

3. The filling loop will consist of two isolating taps and a separate temporary filling pipe with connection fittings.

4. Fit the temporary filling pipe, and tighten the two nuts on the pipe to the taps.

5. Fully open one of the taps first, and then while watching the pressure gauge, carefully open the second tap.

6. When the needle on the pressure gauge indicates between 1 and 2 bar, turn both taps off.

7. The temporary filling loop pipe must be disconnected and completely removed after the system is pressurised. (Ensure the two isolating taps are in the OFF position before disconnecting.) Keep the pipe in a safe place.

4.3 'Service Due' Message (Fig. 3)

1. **When activated** the 'Service Due' message will be shown on the boiler display after 11 months operation.

2. Please contact your Installer, Annual Service Provider or Baxi Customer Support on 0344 871 1545 to arrange your Annual Service.

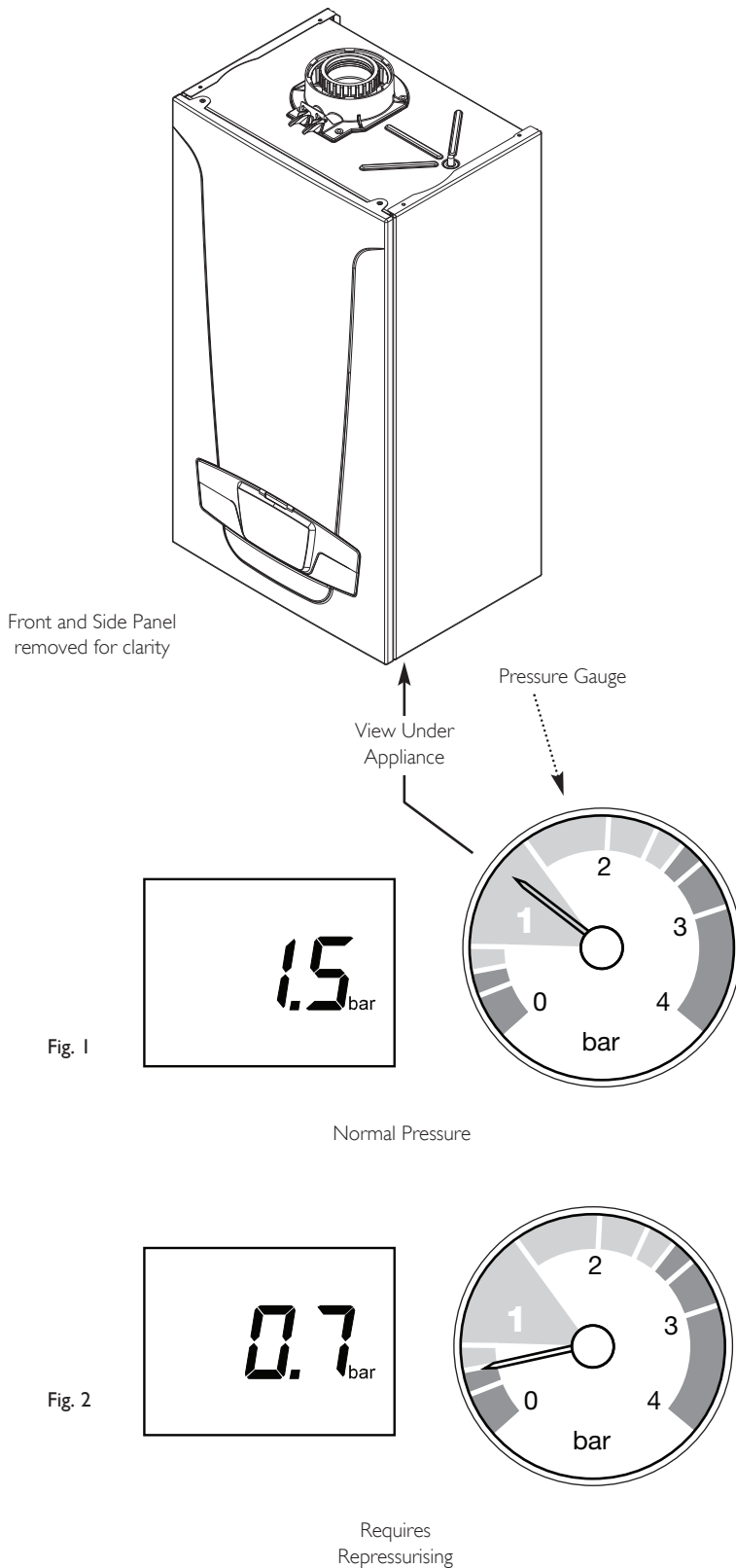

Fig. 1

Normal Pressure

Fig. 2

Requires
Repressurising

'Service Due'
Message
When activated
'Sd' will show for
three seconds,
alternating with the
boiler temperature.

Fig. 3

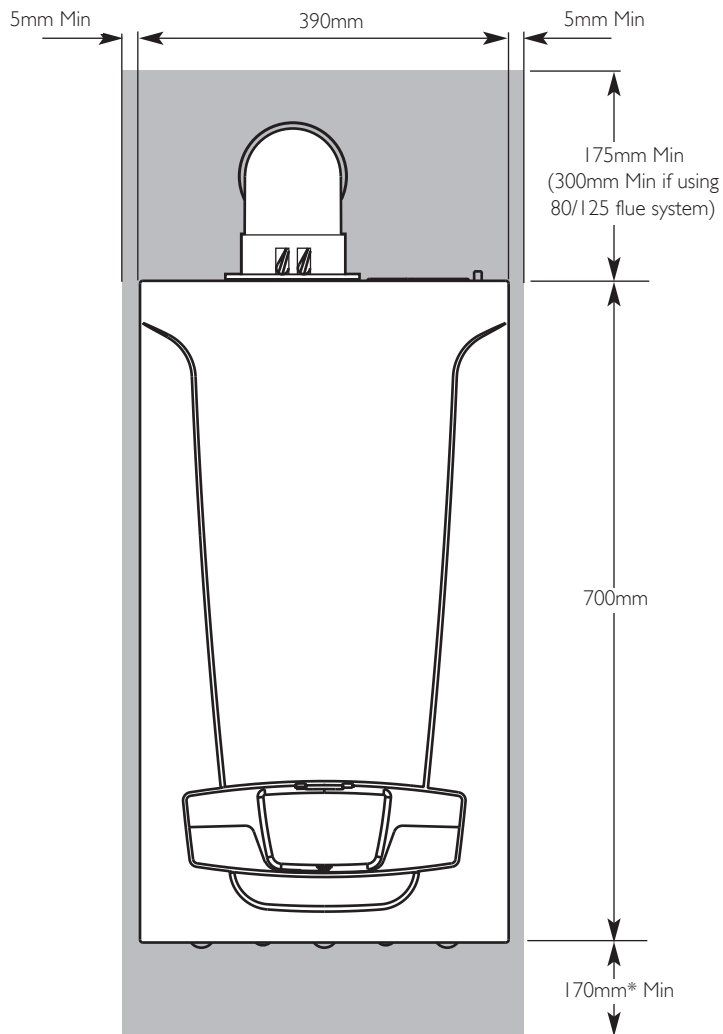

Fig. 4

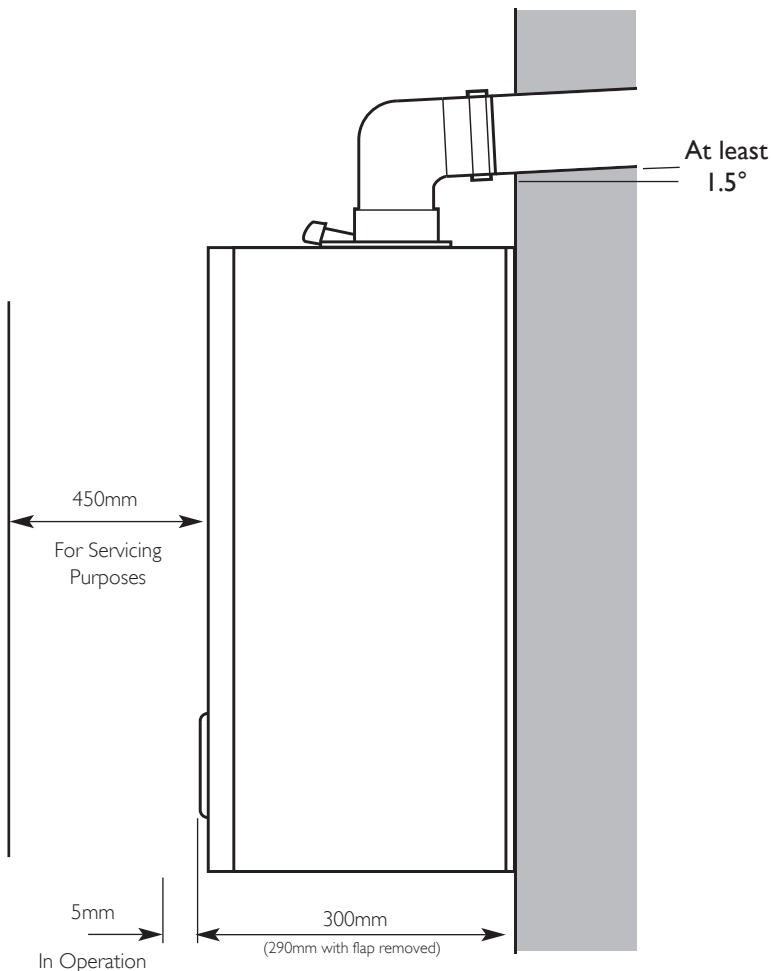

Fig. 5

5.0 Clearances

5.1 For your Safety

1. This appliance must have been installed in accordance with the manufacturer's instructions and the regulations in force.

2. Any modification that may interfere with the normal operation of the appliance without express written permission from the manufacturer or his agent could invalidate the appliance warranty. In GB this could also infringe the Gas Safety (Installation and Use) Regulations.

GB - Heating Industry definition meaning England, Scotland, Wales, Northern Ireland, Isle of Man and the Channel Isles

3. Your boiler must not be operated without the casing correctly fitted.

4. Do not interfere with any sealed components on this boiler.

5. Take note of any warning labels on your boiler.

6. Your boiler should have the following minimum clearances for Safety and Maintenance (Figs. 4 & 5):-

Top	- 175mm
Bottom	- 170mm*
Left side	- 5mm
Right Side	- 5mm
Front	- 5mm (In Operation) - 450mm (For Servicing)

*This is MINIMUM recommended dimension. Greater clearance will aid installation and maintenance.

7. If your boiler is installed in a compartment, do not use it for storage purposes. Do not obstruct any purpose provided ventilation openings.

8. Flammable materials must not be stored in close proximity to your boiler.

9. Avoid skin contact when your boiler is in operation, as some surfaces may get hot e.g. pipework.

10. Ensure that the flue terminal, outside the house, does not become damaged or obstructed, particularly by foliage.

11. It is important that the condensate drain system is not blocked, modified or damaged in any way as this would affect the operation of your boiler. Your installer should have insulated any exposed pipework.

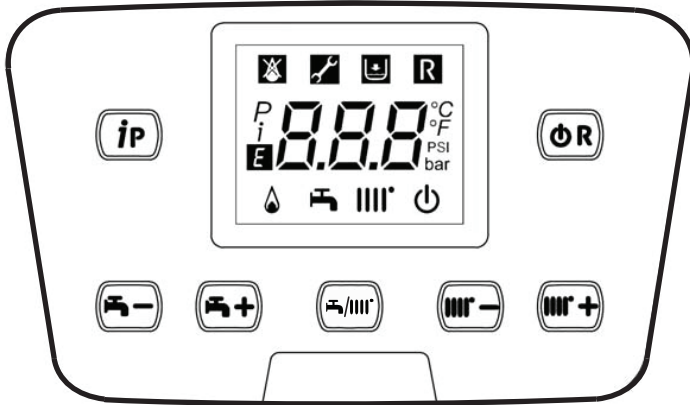

Table Of Error Codes

E 09	Gas Valve Connection Cable
E 15	Gas Valve Fault
E 20	Central Heating NTC Fault
E 28	Flue NTC Fault
E 40	Central Heating Return NTC Fault
E 55	Calibration Required
E 109	Pre-circulation Fault
E 110	Safety Thermostat Operated
E 117	Primary System Water Pressure Too High
E 118	Primary System Water Pressure Too Low
E 125	Circulation Fault (Primary)
E 128	Flame Failure
E 130	Flue NTC Operated
E 133	Interruption Of Gas Supply or Flame Failure
E 134	Elapsed Time - Gas Valve Open Without Gas
E 135	Interruption Of Gas Supply (Internal Error)
E 154	Flow/Return Sensor Temperature Test
E 160	Fan or Fan Wiring Fault
E 270	Circulation Fault (Dry Fire)
E 321	Hot Water NTC Fault
E 384	False Flame

6.0 Error Codes

6.1 List of Error Codes

1. The display shows two types of signals: and **R**. In both cases the display shows **E** symbol and the numeric value of the error (see the "error table" below).
2. The spanner cannot be reset by the user. Please contact your Installer, Annual Service Provider or Baxi Customer Support on 0344 871 1545.
3. **R** Fault errors can be reset by pressing the button.

WARNING: If an error code (if different from the ones described below) appears on the display or a certain fault appears frequently, contact your Installer, Annual Service Provider or Baxi Customer Support on 0344 871 1545.

7.0 Legislation

7.1 Installation, Commissioning, Service & Repair

1. This appliance must be installed in accordance with the manufacturer's instructions and the regulations in force. Read the instructions fully before installing or using the appliance.
2. In GB, this must be carried out by a competent person as stated in the Gas Safety (Installation & Use) Regulations.
3. **Definition of competence:** A person who works for a Gas Safe registered company and holding current certificates in the relevant ACS modules, is deemed competent.
4. In IE (Eire), this must be carried out by a competent person as stated in I.S. 813 "Domestic Gas Installations".

Lifting - This product should be lifted and handled by two people. Stooping should be avoided and protective equipment worn where necessary. Carrying & lifting equipment should be used as required, e.g. when installing in a loft space.

All Gas Safe registered engineers carry an ID card with their licence number and a photograph. You can check your engineer is registered by telephoning 0800 408 5500 or online at www.gassaferegister.co.uk

The boiler meets the requirements of Statutory Instrument "The Boiler (Efficiency) Regulations 1993 No 3083" and is deemed to meet the requirements of Directive 92/42/EEC on the energy efficiency requirements for new hot water boilers fired with liquid or gaseous fuels:-

The product data in Section 9.0 satisfies the requirements of EU regulations no. 811/2013 & no. 813/2013 supplementing directive 2010/30/EU

Type test for purpose of Regulation 5 certified by:
Notified Body 0085.

Product/Production certified by:
Notified Body 0086.

For GB/IE only.

7.2 Benchmark Commissioning Checklist

1. Please ensure that the installer has fully completed the Benchmark Checklist on the inside back pages of the installation instructions supplied with the product and that you have signed it to say that you have received a full and clear explanation of its operation. The installer is legally required to complete a commissioning checklist as a means of complying with the appropriate Building Regulations (England and Wales).
2. All installations must be notified to Local Area Building Control either directly or through a Competent Persons Scheme. A Building Regulations Compliance Certificate will then be issued to the customer who should, on receipt, write the Notification Number on the Benchmark Checklist.
3. This product should be serviced regularly to optimise its safety, efficiency and performance. The service engineer should complete the relevant Service Record on the Benchmark Checklist after each service.
4. The completed Benchmark Checklist may be required in the event of any warranty work.

8.0 Warranty & Service

8.1 General

To make sure your boiler warranty is activated and maintained, it is essential that the:

1. Benchmark checklist is completed by your installer
2. Warranty is registered within 30 days
3. Boiler has an annual service

Please note that failure to adhere to terms and conditions will make your warranty invalid.

8.2 Standard Warranty Terms and Conditions

Warranty Registration, Service & Repair

For full terms and conditions, visit www.baxi.co.uk/terms.

Benchmark Checklist

The Benchmark Checklist will be completed by your installer and records that the boiler has been installed and commissioned correctly. It can be found at the back of the installation and service manual and should be kept in a safe place for the life of the boiler. We will check that the Benchmark Checklist has been completed on an in-warranty visit.

Ways to register your warranty

If your boiler is eligible for an extended warranty, your installer may register the product on your behalf and provide you with the relevant documentation. Please check with your installer.

Should this not be the case, you can register your warranty online at www.baxi.co.uk/registration

8.0 Warranty & Service

Annual Service

A service must be completed every 12 months from the date of installation to maintain your warranty.

This service must be completed by one of the following:

- A Gas Safe registered installer/engineer
- Baxi Customer Support; call us 0344 871 1545

Please make sure that your engineer has logged the service information at the back of the installation and service manual. You will be asked for your service history on any in-warranty repair visit.

If you experience a problem with your boiler

For any in or out of warranty repair, Baxi Customer Support is on hand to help you. Call our award-winning team to arrange for one of our nationwide team of Gas Safe registered engineers to visit.

If your product is in warranty, everything is free of charge, subject to our warranty terms and conditions. If it is out of warranty, we can still help and offer a range of options you can choose from to suit your needs.

Contact Baxi Customer Support 0344 871 1545

Opening hours

Monday - Friday, 8.00am - 6.00pm

Weekends and Bank Holidays, 8.30am - 2.00pm

Please note calls may be recorded for training and monitoring purposes.

When contacting Baxi Customer Support, please have the following information to hand:

- Boiler serial number. This can be found on the appliance.
- Proof of purchase if you do not have the boiler serial number.

Please note that for in-warranty repairs, our engineers will ask to see your service history record, completed Benchmark Checklist and details of your installer. These can all be found in the installation and user manuals.

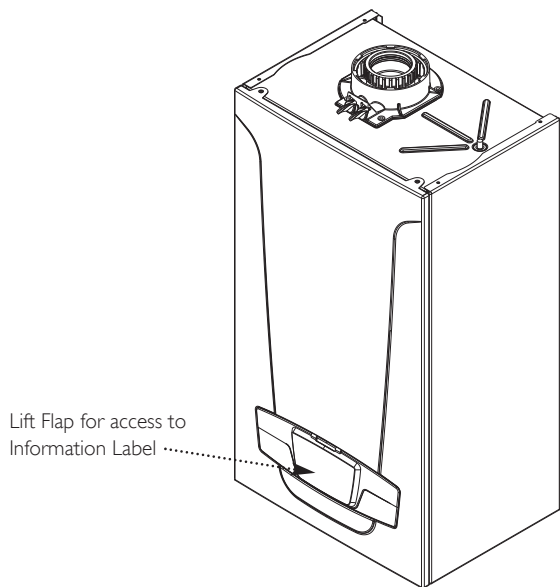

Product fiche for boiler space heaters

Potterton Ultra System		12	15	18	24	28
Seasonal space heating energy efficiency class		A	A	A	A	A
Rated heat output (<i>Prated or Psup</i>)	kW	12	15	18	24	28
Seasonal space heating energy efficiency	%	93	93	93	93	93
Annual energy consumption	kWh GJ	10278 37	12778 46	15556 56	20556 74	24167 87
Sound power level L_{WA} indoors	dB	52	49	49	52	53



See

For specific precautions about assembling, installing and maintaining, consult the relevant section as detailed on the Contents page.

9.2 Package Fiche - Boilers

Package fiche for boilers indicating the space heating energy efficiency of the package

Seasonal space heating energy efficiency of boiler

①
'I' %

Temperature control

from fiche of temperature control

Class I = 1%, Class II = 2%, Class III = 1.5%,
 Class IV = 2%, Class V = 3%, Class VI = 4%,
 Class VII = 3.5%, Class VIII = 5%

②
 + %

Supplementary boiler

from fiche of boiler

Seasonal space heating energy efficiency (in %)

③
 $(\text{ } - \text{'I'}) \times 0.1 = \pm \text{ } \%$

Solar contribution

from fiche of solar device

Collector size (in m²)

Tank volume (in m³)

Collector efficiency (in %)

Tank rating ⁽¹⁾
 A* = 0.95, A = 0.91,
 B = 0.86, C = 0.83,
 D - G = 0.81

$$(\text{'III'} \times \text{ } + \text{'IV'} \times \text{ }) \times 0.9 \times (\text{ } / 100) \times \text{ } = + \text{ } \% \quad \text{④}$$

(1) If tank rating is above A, use 0.95

Supplementary heat pump

from fiche of heat pump

Seasonal space heating energy efficiency (in %)

⑤
 $(\text{ } - \text{'I'}) \times \text{'II'} = + \text{ } \%$

Solar contribution AND Supplementary heat pump

select smaller value

$$0.5 \times \text{ } \text{ OR } 0.5 \times \text{ } = - \text{ } \% \quad \text{⑥}$$

Seasonal space heating energy efficiency of package

⑦
 %

Seasonal space heating energy efficiency class of package

<input type="checkbox"/>	<input type="checkbox"/>	<input type="checkbox"/>	<input type="checkbox"/>	<input type="checkbox"/>	<input type="checkbox"/>	<input type="checkbox"/>	<input type="checkbox"/>	<input type="checkbox"/>	<input type="checkbox"/>
G	F	E	D	C	B	A	A⁺	A⁺⁺	A⁺⁺⁺
<30%	≥30%	≥34%	≥36%	≥75%	≥82%	≥90%	≥98%	≥125%	≥150%

Boiler and supplementary heat pump installed with low temperature heat emitters at 35°C ?

from fiche of heat pump

⑦
 + (50 x 'II') = %

The energy efficiency of the package of products provided for in this fiche may not correspond to its actual energy efficiency once installed in a building, as this efficiency is influenced by further factors such as heat loss in the distribution system and the dimensioning of the products in relation to building size and characteristics.

AD-3000743-01

- I The value of the seasonal space heating energy efficiency of the preferential space heater, expressed in %.
- II The factor for weighting the heat output of preferential and supplementary heaters of a package as set out in the following table.

- III The value of the mathematical expression: $294/(11 \cdot \text{Prated})$, whereby 'Prated' is related to the preferential space heater.
- IV The value of the mathematical expression $115/(11 \cdot \text{Prated})$, whereby 'Prated' is related to the preferential space heater.

Weighting of boilers

$\text{P}_{\text{sup}} / (\text{Prated} + \text{P}_{\text{sup}})^{(1)(2)}$	II, package without hot water storage tank	II, package with hot water storage tank
0	0	0
0.1	0.3	0.37
0.2	0.55	0.70
0.3	0.75	0.85
0.4	0.85	0.94
0.5	0.95	0.98
0.6	0.98	1.00
≥ 0.7	1.00	1.00

(1) The intermediate values are calculated by linear interpolation between the two adjacent values.
 (2) Prated is related to the preferential space heater or combination heater.

Package efficiency

Potterton Ultra System		12	15	18	24	28
Temperature control X	%					
Temperature control Y	%					

Warning !

If you smell gas

Do not operate light switches
Do not operate any electrical equipment
Do not use a telephone in the hazardous area
Extinguish any naked flame and do not smoke
Open windows and doors in the hazardous area
Turn off the gas supply at the meter
Warn any other occupants and vacate the premises
Telephone the National Gas Emergency Service on:-
0800 111 999

Faulty boiler

If it is known or suspected that a fault exists on the boiler, it must not be used until the fault has been corrected by a competent person.

In an Emergency

If a water or gas leak occurs or is suspected, the boiler can be isolated at the inlet valves as follows;

1. If a water or gas leak occurs or is suspected, the boiler can be isolated at the inlet valves by turning their taps through 90° (1/4 turn) (Fig. 6).

3. Call your Installer or Service Engineer as soon as possible.

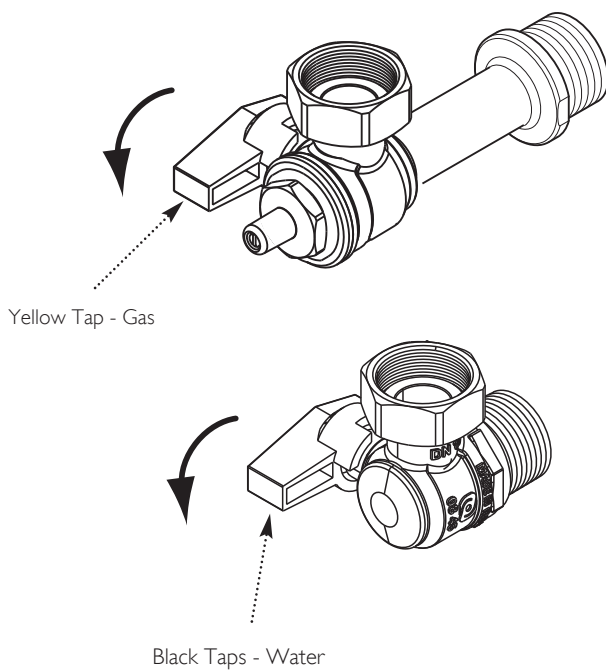

Fig. 6

11.0 Disposal

11.1 Disposal and Recycling

NOTE: Removal and disposal of the boiler must be carried out by a qualified person in accordance with local and national regulations.

Baxi Customer Support



0344 871 1545

Opening hours

Monday - Friday, 8.00am-6.00pm

Weekends and Bank Holidays, 8.30am-2.00pm

Please note calls may be recorded for training and monitoring purposes



baxi.co.uk

Register now to activate your warranty:

www.baxi.co.uk/registration

For the warranty to be maintained, please make sure...

- 1** Benchmark checklist is completed
- 2** Warranty is registered within 30 days
- 3** The boiler has an annual service

For full terms and conditions, visit www.baxi.co.uk/terms. Failure to adhere to terms and conditions will void your manufacturer's warranty.



Baxi
Brooks House,
Coventry Road,
Warwick, CV34 4LL



Please ensure the boiler is installed in accordance with these installation instructions and that you adhere to the Building Regulations.

e&oe

All descriptions and illustrations provided in this document have been carefully prepared but we reserve the right to make changes and improvements in our products which may affect the accuracy of the information contained in this leaflet. All goods are sold subject to our standard Conditions of Sale which are available on request.

CE
0086



part of **BAXI**