

# elco

## D-TRON

DUOBLOCK BURNERS

XXX - 34000 kW



# INDUSTRIAL BURNERS AS PART OF A COMPREHENSIVE SOLUTION

## On track to success with ELCO

Wherever large-scale power generation is needed, ELCO has a proven track record of being a partner you can depend on. Whether it involves the provision of a heating system for a major property development, thermal process engineering in industry, the production of process steam, or the use of special fuels, we will design, construct and install a tailor-made total solution in accordance with your specific requirements.

## Competent advice

In the developing of an heating solution the road to success is mapped out from the very beginning. Competent advice is therefore of crucial importance. With over 80 years of experience as well as our own research and development, we have the know-how that you need to see your project come to fruition: from conceptual design, planning, project development and project management to commissioning and the provision of continuous service support for the installation throughout its entire life cycle.

## First-class products

ELCO industry burners enjoy a first-class reputation. This is built on many years of experience from a wide variety of applications and methodical research and development. Whether the demands stems from extreme environmental conditions, such as those experienced on an oil rig in the Caspian Sea, to keeping pollutant emissions in a Swiss production facility to a minimum, renowned boiler and system manufacturers trust in our products and opt for the tailor-made engineering solutions of ELCO.

## Comprehensive system competency

Our know-how spans the whole range of burner peripheral equipment. In addition to combustion engineering, we cover every aspect of measurement and control engineering for efficient, safe and permanently fault-free operation of your heating installation. Everything from one source and perfectly matched.

## Outstanding service

As an ELCO customer, you can depend on your installation to perform reliably. Our guarantee is backed up by a service that sets standards in the industry.

## Index

Duoblock burners: the basic concept	3
Designation of D-TRON components	3
Range overview	4
Main characteristics of the range	6
Configurations, variants and accessories	7
Electronic version with BMS	8
Ventilator	9
Pressure drops	10
Overall dimensions	12
Gas trains matching	17

# DUOBLOCK BURNERS: THE BASIC CONCEPT

## All the benefits of the separate ventilation

In contrast to monoblock burners, duoblock burners are made up of two units, or blocks, as the name implies: the burner head with the air inlet, and the separately-installed fan; the two units are connected via an air duct.



The separate installation of the fan offers several benefits:

- the fan can be installed in a separate room, for instance in the cellar; this results in considerably lower noise levels in the boiler room; when the fan is installed in the same room, a fan enclosure can be used to achieve optimum sound absorption, without inhibiting access to the burner;
- less space required in front of the boiler and in the combustion chamber;
- individual fan layout with optimum adaptation of the fan characteristic curve to suit the pressure ratio of the heat generator; this guarantees pulsation-free and stable burner behaviour, even on heat generators with high resistance on the exhaust side;
- combustion air can be pre-heated to increase installation efficiency;
- lower weight loading on the boiler front.

## DESIGNATION OF D-TRON COMPONENTS

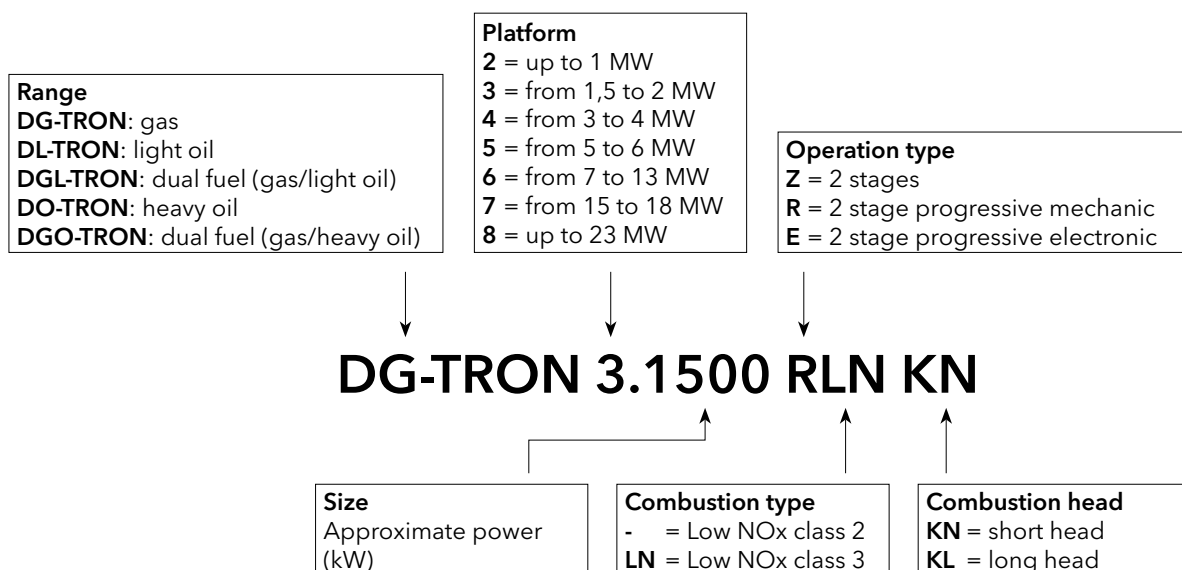

# RANGE OVERVIEW



## DG-TRON

Gas - Low NOx Class 2 (< 120 mg/kWh)

Class 2

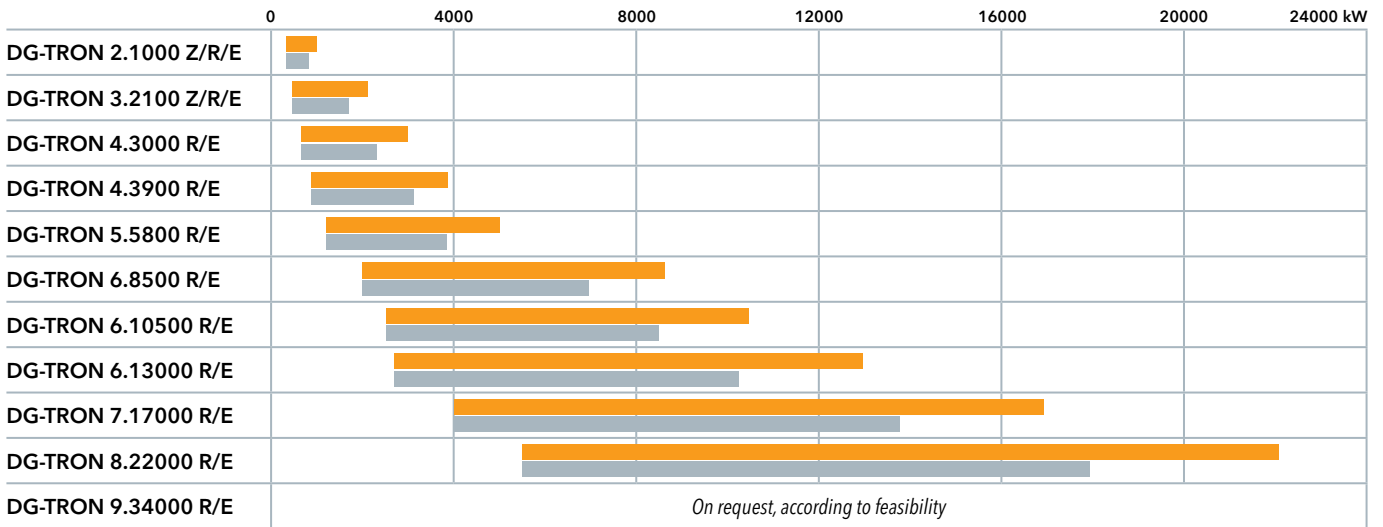

Standard version T<sub>air</sub> = 20°C    Hot air version T<sub>air</sub> = 200°C



## DG-TRON

Gas - Low NOx Class 3 (< 80 mg/kWh)

Class 3

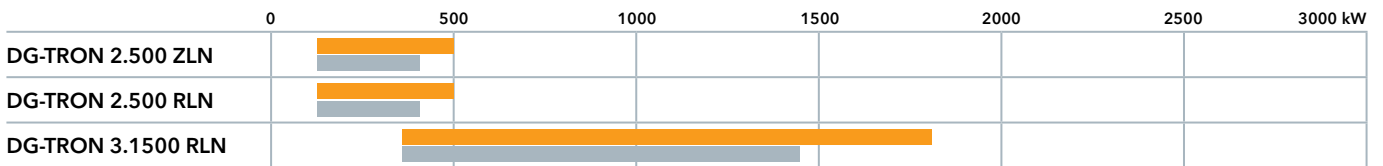

Standard version T<sub>air</sub> = 20°C    Hot air version T<sub>air</sub> = 200°C

## DL-TRON

Light oil - Low NOx Class 2 (< 185 mg/kWh)

### Oil pump on board

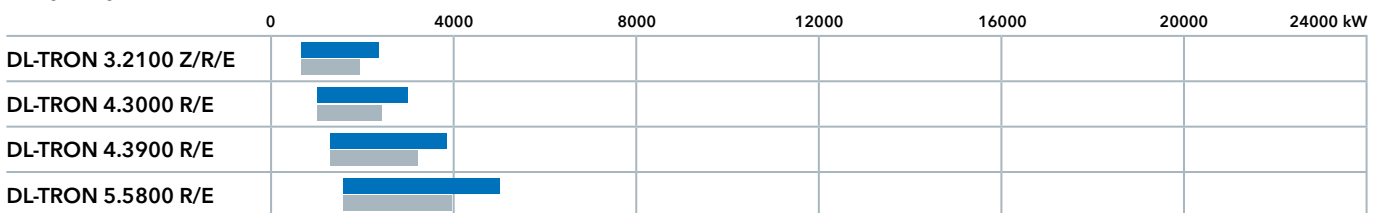

Standard version T<sub>air</sub> = 20°C    Hot air version T<sub>air</sub> = 200°C

### Separated oil pumping unit (not included)

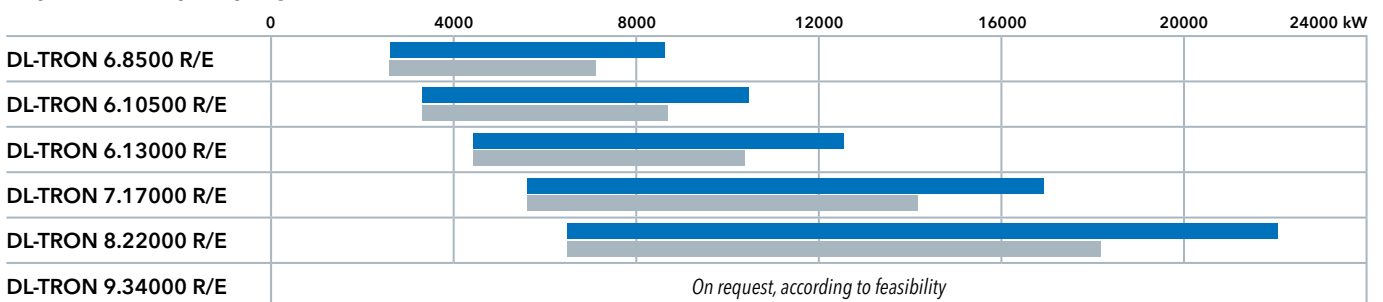

Standard version T<sub>air</sub> = 20°C    Hot air version T<sub>air</sub> = 200°C

# DGL-TRON

Natural gas/light oil

## Oil pump on board

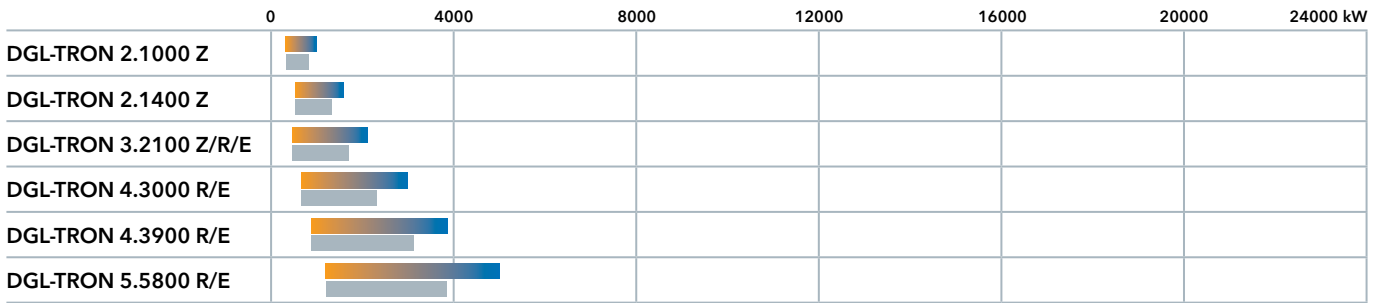

■ Standard version T<sub>air</sub> = 20°C   ■ Hot air version T<sub>air</sub> = 200°C

## Separated oil pumping unit (not included)

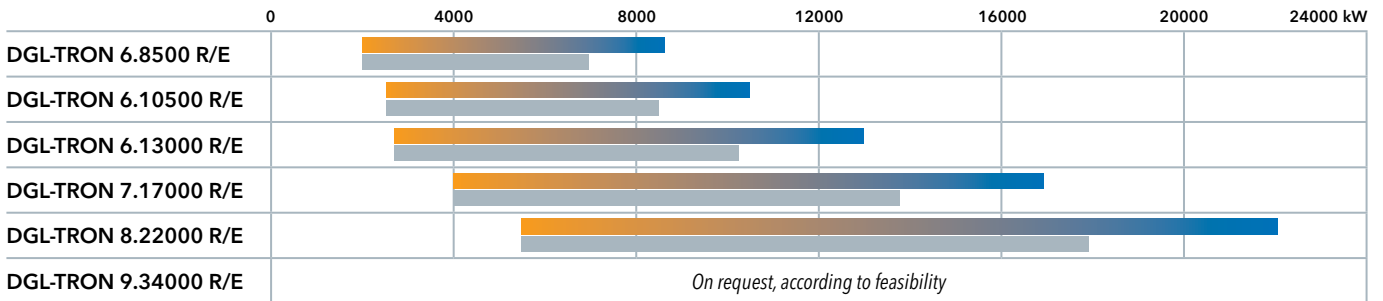

■ Standard version T<sub>air</sub> = 20°C   ■ Hot air version T<sub>air</sub> = 200°C

# DGO-TRON

Natural gas/heavy oil - max viscosity 50°E at 50°C

## Oil pump/heater on board

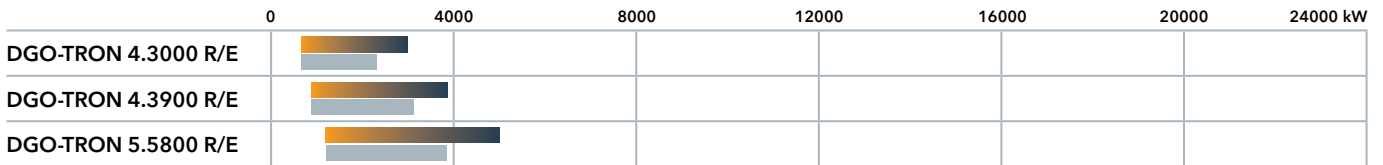

■ Standard version T<sub>air</sub> = 20°C   ■ Hot air version T<sub>air</sub> = 200°C

## Separated oil pumping unit (not included)

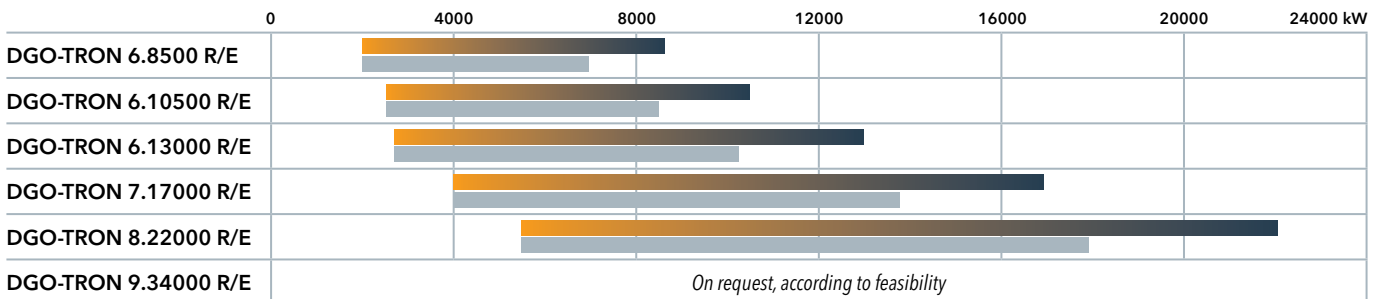

■ Standard version T<sub>air</sub> = 20°C   ■ Hot air version T<sub>air</sub> = 200°C

**ELECTRONIC VERSIONS** with Siemens LMV 51.1: available on request

# MAIN CHARACTERISTICS OF THE RANGE

## Maximum flexibility for highly customized solutions

Thanks to their extreme flexibility and ease of use D-TRON burners are suitable for all types of installation from 200 kW up to 34 MW.

Burners can be assembled with air duct connection in different layouts in order to meet a wide range of specifications in terms of performance and overall dimensions.

Terminal block configuration is provided as standard; versions with integrated control panel are available on request.

## Low maintenance, high reliability

All D-TRON models feature easy maintenance. Access to the combustion head and to the internal components is allowed from the housing top cover with a single operation, without removing the burner from the boiler. The clear layout allows rapid cleaning of the mechanical components, keeping the installation always in good conditions.



## Hot air configuration

D-TRON range can run in standard configuration with air up to 60°C.

Versions suitable to work with pre-heated combustion air up to 200°C can be used in order to achieve greater values of efficiency.

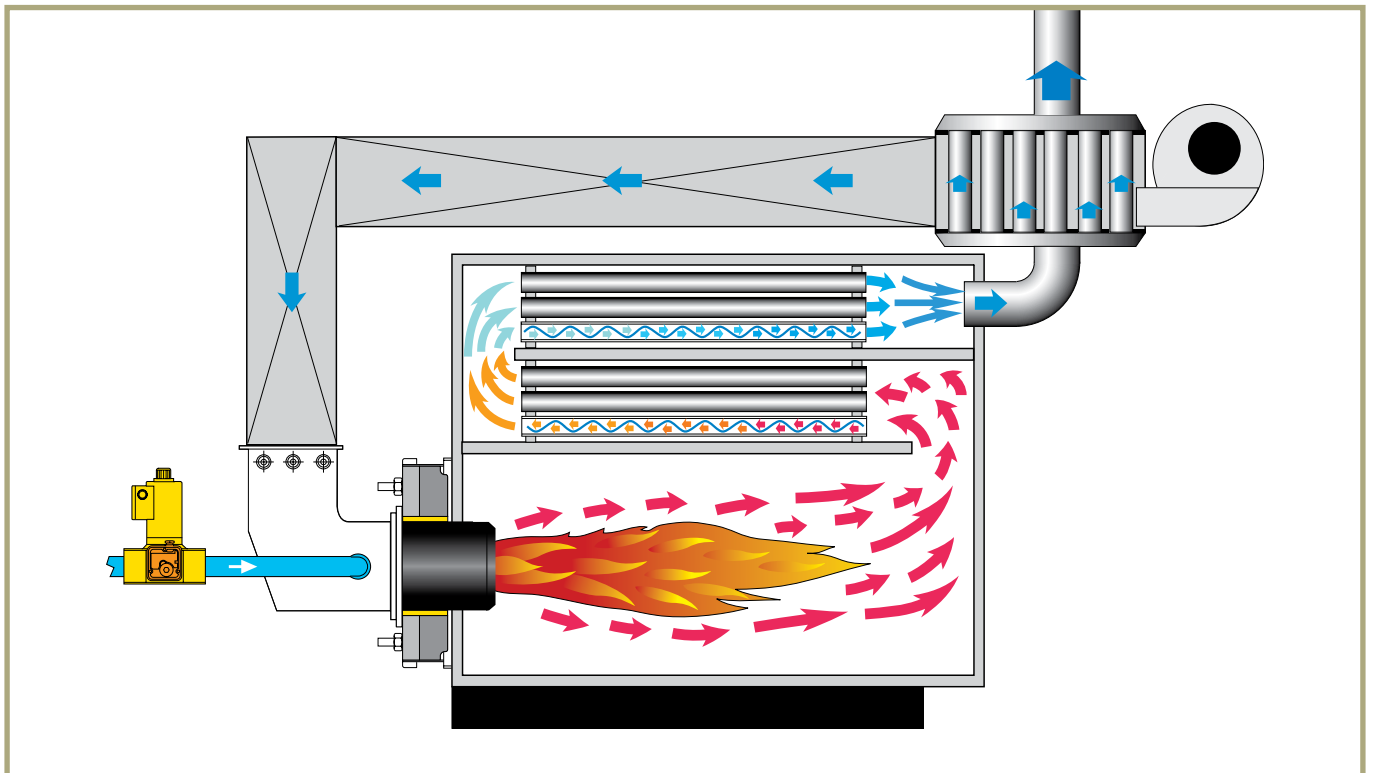

*Installation scheme with smoke exchanger and heat recuperator*

# CONFIGURATIONS, VARIANTS AND ACCESSORIES



**Standard configuration:**  
loose version with  
derivative panel



**IP55 Switch cabinet  
configuration:**  
version with assembled  
or remote switch cabinet



**Pre-heating  
pump station**



**Separate ventilator**



**Gas train unit**



**Modulation Kit**



**Gas governor/filter**  
Compulsory EN676



**Max pressure switch**



**Tightness control**  
Compulsory over 1200 kW

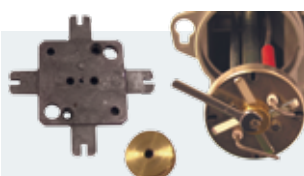

**LPG/Natural gas kit**

# ELECTRONIC VERSION WITH BMS

INVERTER SYSTEM  
O<sub>2</sub>-CO TRIM CONTROL  
MONITORING APPLICATION

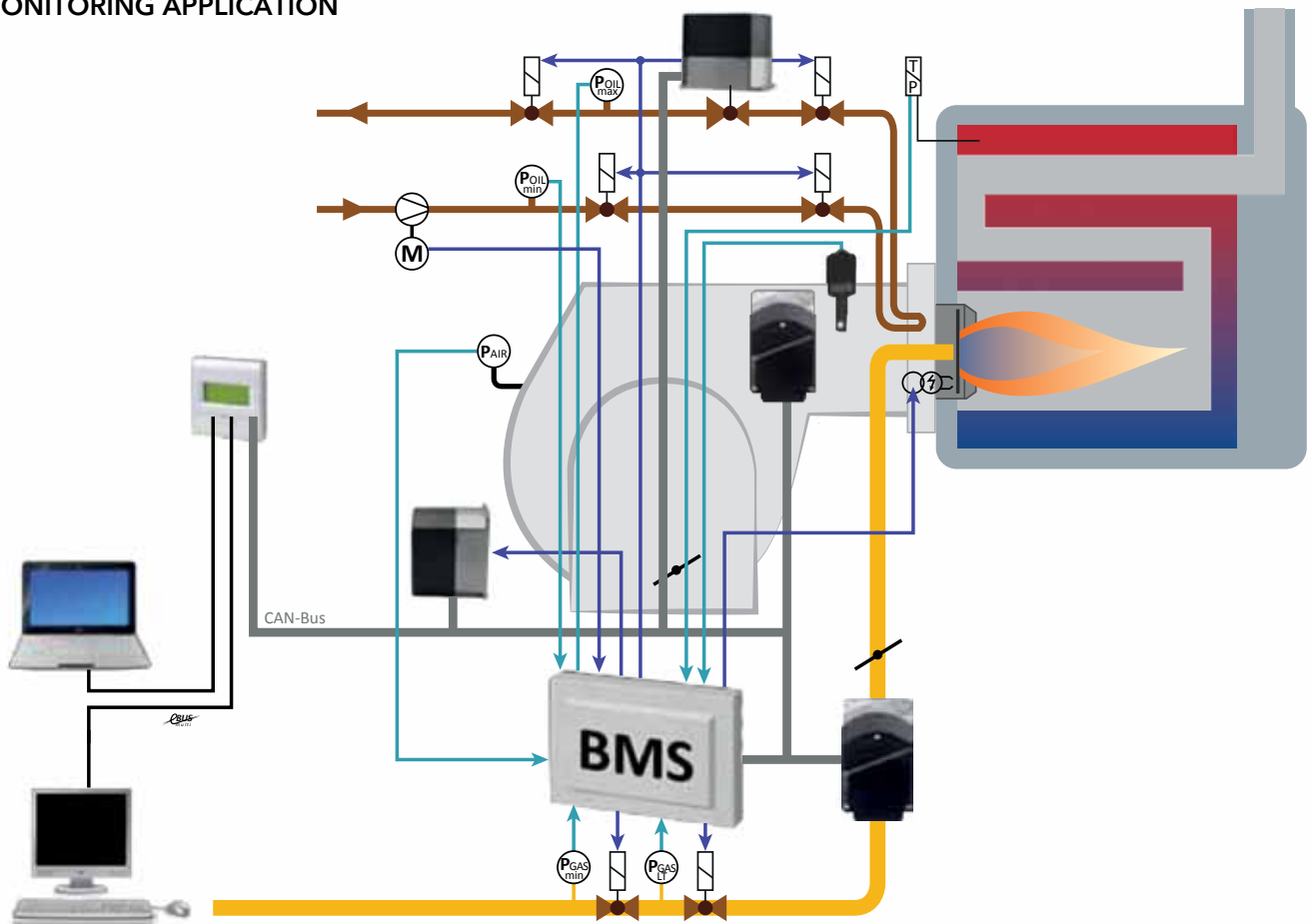

**BMS (Burner Management System)** allows to improve performance and efficiency of modern firing installation. This system is designed to be matched with an extensive range of components such as flame, temperature and pressure sensors, gas valves, variable speed fan motors and oxygen control that can be managed from different bus interfaces

	Turndown ratio			Kit VSD-inverter	Kit O <sub>2</sub> -CO trim	Additional functions
	standard	with inverter	oil side			
DG-TRON	1÷6	1÷8	-	Kit	Kit	Flame monitoring sensors
DL-TRON	-	1÷5	1÷4	Kit	Kit	
DGL-TRON	1÷6	1÷8	1÷4	Kit	Kit	Communication interfaces
DO-TRON	-	1÷4	1÷4	Kit	Kit	
DGO-TRON	1÷6	1÷8	1÷4	Kit	Kit	Display interface



# VENTILATOR

## How to choose the correct ventilator

According to the application output or the fuel flow rate we need to calculate the **air needed** considering the following data:

- Output / Fuel air flow;
- Temperature of combustion air;
- Backpressure in the combustion chamber;
- Sea level altitude.

In order to dimension the correct ventilator the following calculation has to be made:

1. Air flow needed
2. Pressure needed

First of all we need to calculate the air flow needed in function of Nm<sup>3</sup>/h for gas or kg/h for oil and multiply it for the following suggested coefficients:

**Natural gas: K=12**

**Light oil: K=15,7**

**Heavy oil: K=15**

Example:

**1000 Nm<sup>3</sup>/h of gas**

The quantity of air will be:

**1000 [Nm<sup>3</sup>/h] x 12 = 12000 m<sup>3</sup>/h of air**

This value must be adjusted according to the following:

1. temperature of combustion air (standard 20° C; see table for different temperature);
2. sea level (refer to the table for correction factors);
3. air loss of the connecting pipes between burner head and ventilator (estimated to **5%**).

Results will be the following for an installation at 500 m from the sea level and with air at 50°C:

**12000 [m<sup>3</sup>/h] x 1,05 / 0,855 = 14737 m<sup>3</sup>/h**

### Total air pressure:

to finalize the calculation we shall consider the following factors:

- head loss of the burner\* (see following pages);
- backpressure in the combustion chamber;
- additional loss given from accessories like heat exchanger, filters, ...

\*: pressure losses calculated at sea level at 20°C; the value must be adjusted according to the correction factor

**1000 Nm<sup>3</sup>/h gas for DG-TRON 6.10500**

10000 kW (L.C.V. 8570 kcal/Nm<sup>3</sup>)

- head loss = **35/0,855 = 42 mbar**

- backpressure installation = **15 mbar**

- additional exchanger = **15 mbar**

**Total: 42+15+15 = 72 mbar**

Final data achieved for selecting the ventilator:

**1. Air needed = 14737 m<sup>3</sup>/h**

**2. Pressure = 72 mbar**

## Correction factors

Temp. (°C)	Air density (kg/m)	Sea level altitude (m)												
		0	250	500	750	1000	1250	1500	1750	2000	2250	2500	2750	3000
0	1,293	1,073	1,042	1,012	0,982	0,954	0,926	0,899	0,873	0,847	0,823	0,799	0,775	0,753
5	1,270	1,054	1,023	0,993	0,965	0,936	0,909	0,883	0,857	0,832	0,808	0,784	0,761	0,739
10	1,247	1,035	1,005	0,976	0,947	0,920	0,893	0,867	0,842	0,817	0,793	0,770	0,748	0,726
15	1,226	1,017	0,988	0,959	0,931	0,904	0,878	0,852	0,827	0,803	0,780	0,757	0,735	0,714
20	1,205	1,000	0,971	0,943	0,915	0,888	0,863	0,837	0,813	0,789	0,766	0,744	0,722	0,701
25	1,185	0,983	0,955	0,927	0,900	0,874	0,848	0,823	0,799	0,776	0,754	0,732	0,710	0,690
30	1,165	0,967	0,939	0,911	0,885	0,859	0,834	0,810	0,786	0,763	0,741	0,720	0,699	0,678
40	1,128	0,936	0,909	0,882	0,857	0,832	0,807	0,784	0,761	0,739	0,717	0,697	0,676	0,657
50	1,093	0,907	0,881	<b>0,855</b>	0,830	0,806	0,782	0,760	0,738	0,716	0,695	0,675	0,655	0,636
60	1,060	0,880	0,854	0,829	0,805	0,782	0,759	0,737	0,715	0,695	0,674	0,655	0,636	0,617
80	1,000	0,830	0,806	0,782	0,760	0,737	0,716	0,695	0,675	0,655	0,636	0,618	0,600	0,582
100	0,946	0,786	0,763	0,740	0,719	0,698	0,678	0,658	0,639	0,620	0,602	0,585	0,567	0,551
150	0,834	0,693	0,672	0,653	0,634	0,615	0,598	0,580	0,563	0,547	0,531	0,515	0,500	0,486
200	0,746	0,619	0,601	0,584	0,567	0,550	0,534	0,519	0,504	0,489	0,475	0,461	0,448	0,434
250	0,675	0,560	0,544	0,528	0,513	0,498	0,483	0,469	0,456	0,442	0,429	0,417	0,405	0,393
300	0,616	0,511	0,496	0,482	0,468	0,454	0,441	0,428	0,416	0,404	0,392	0,380	0,369	0,359

# PRESSURE DROPS

## D...-TRON 4

Burner head AIR pressure drop

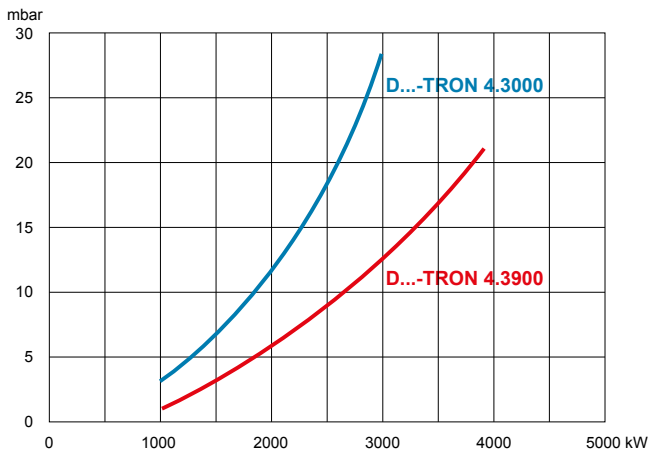

Burner head GAS pressure drop

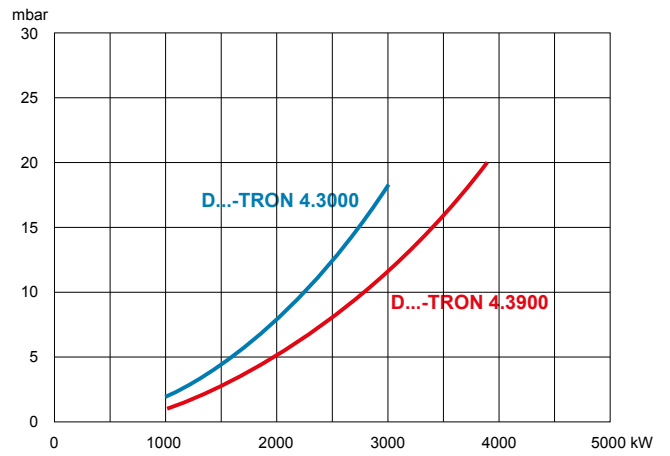

## D...-TRON 5

Pressure drop on AIR side

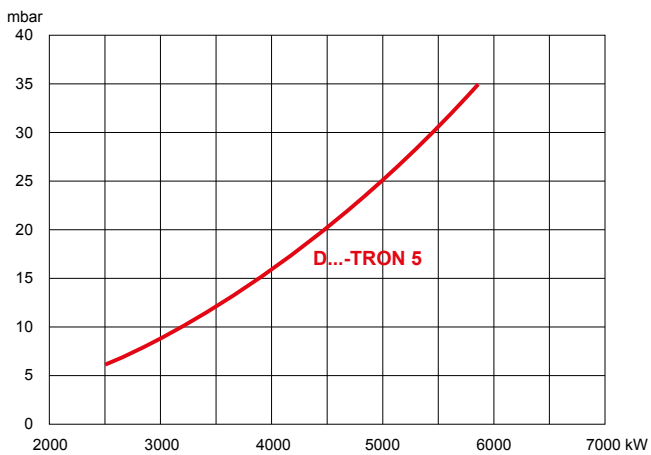

Pressure drop on GAS side

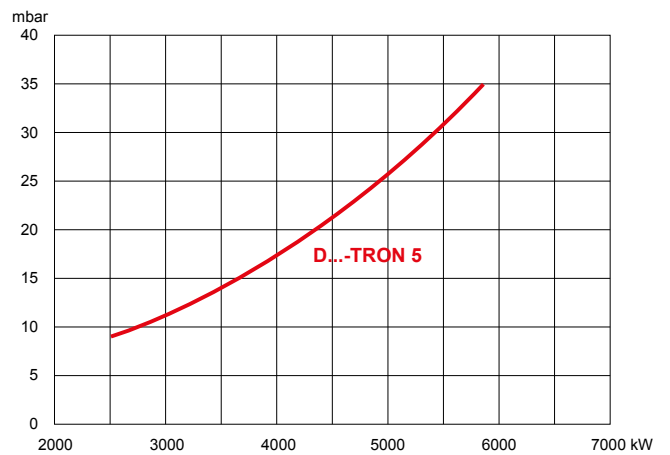

## D...-TRON 6

Pressure drop on AIR side



Pressure drop on GAS side

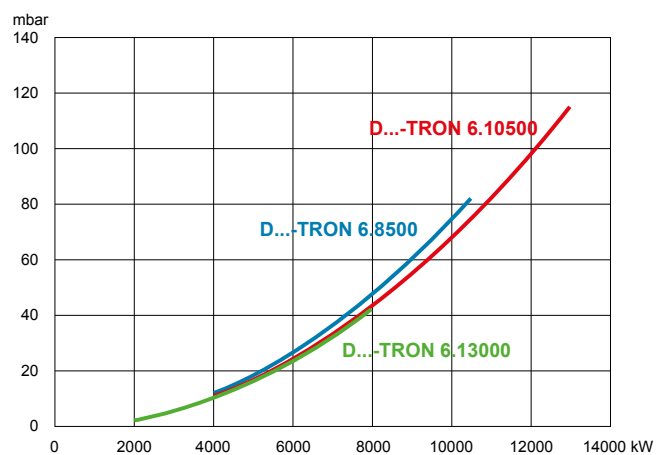

## D...-TRON 7

Pressure drop on AIR side

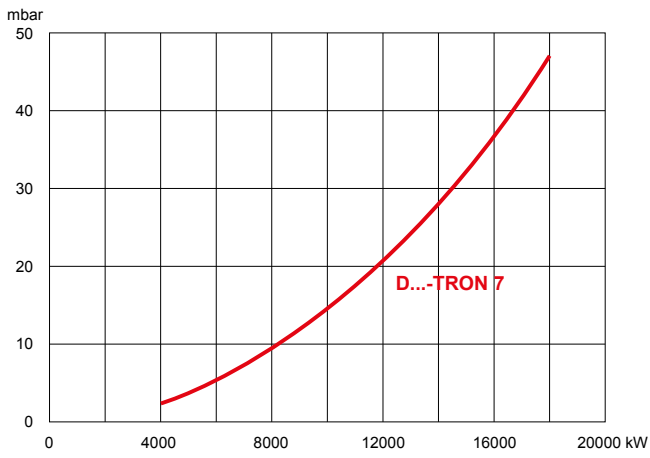

Pressure drop on GAS side

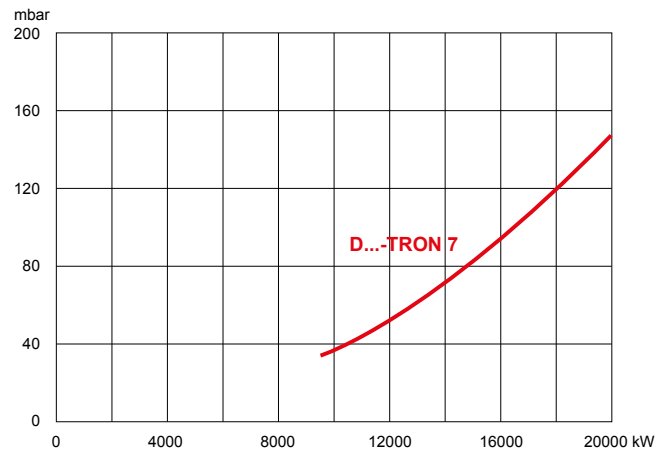

## D...-TRON 8

Pressure drop on AIR side

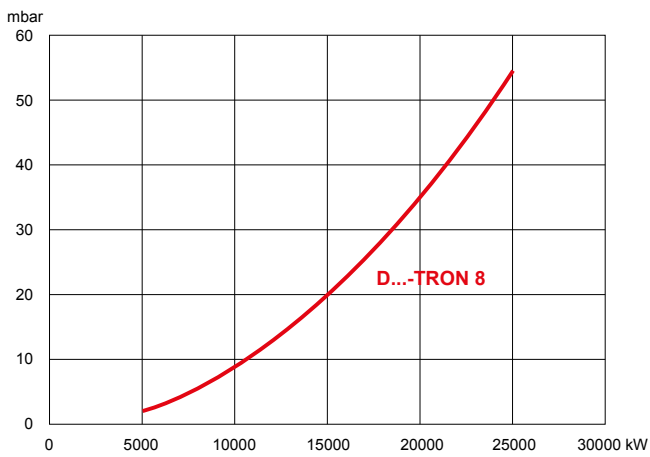

Pressure drop on GAS side

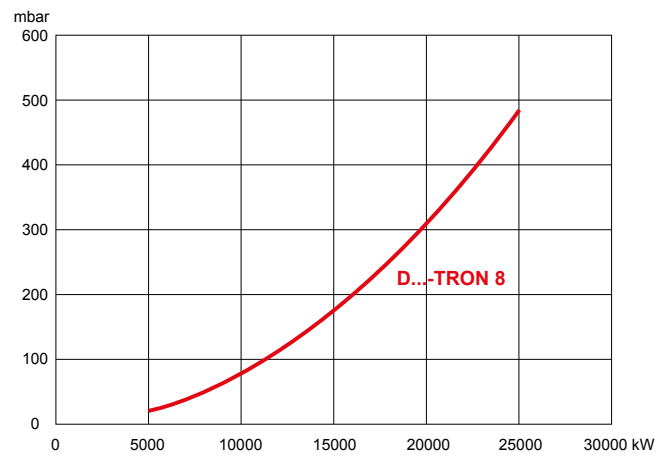

# OVERALL DIMENSIONS

## Burner body

### D...-TRON 2

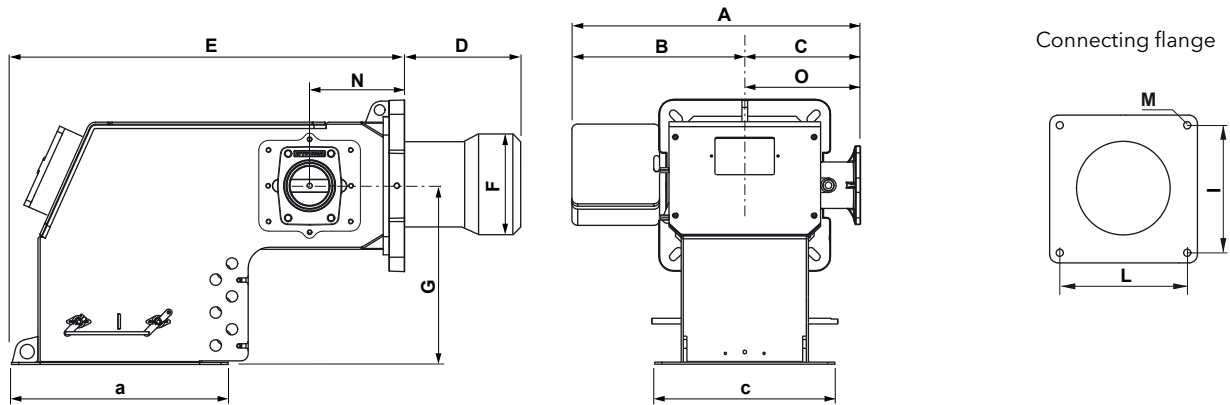

### D...-TRON 3...8

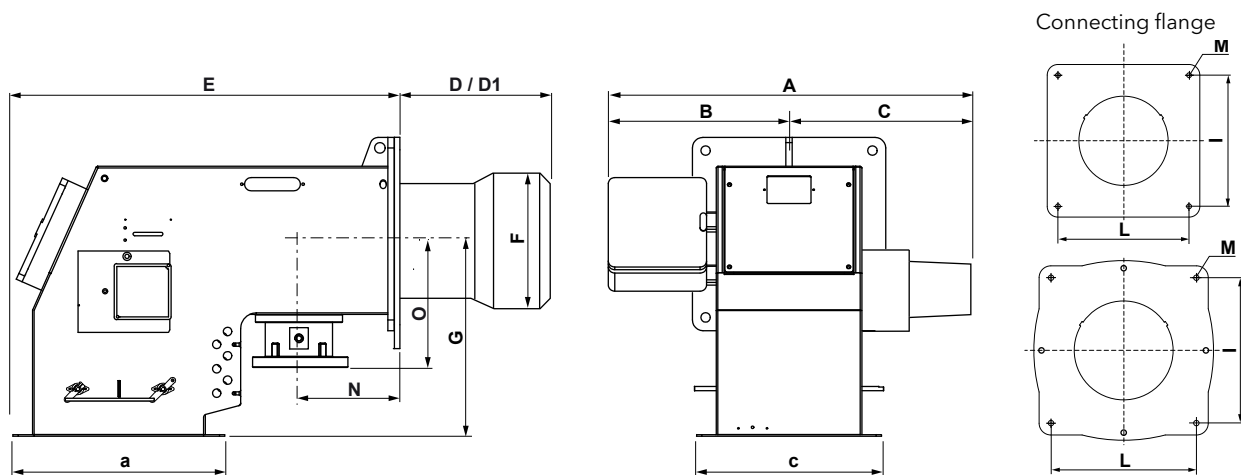

	A	B	C	D	D1	E	F	G	I	L	M	N	O
D...-TRON 2	619	454	165	175	395	560	190	250	190	190	4x M10	140	165
D...-TRON 3	922	444	478	345	545	710	270	375	270	270	4x M16	125	250
D...-TRON 4	971	479	492	345	545	850	320	392	315	315	4x M16	190	250
D...-TRON 5	978	485	493	375	575	810	320	404	330	330	4x M16	195	250
D...-TRON 6	1170	540	630	470	-	1030	420	550	460	460	4x M20	195	232
D...-TRON 7	1270	630	640	590	-	1480	550	670	620	620	8x M20	210	320
D...-TRON 8	1530	800	730	510	-	1560	720	760	800	800	8x M20	220	412

Dimensions in mm  
 D: short head  
 D1: long head

Dimensions make reference to the mechanical versions; data may vary according to the configuration and options installed.

# OVERALL DIMENSIONS

## Air duct

D...-TRON 2-3

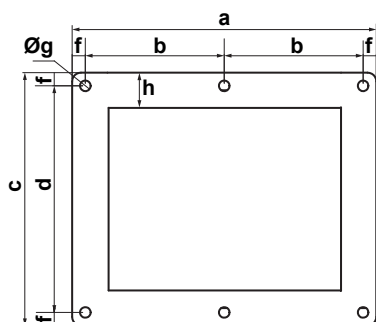

D...-TRON 4-5

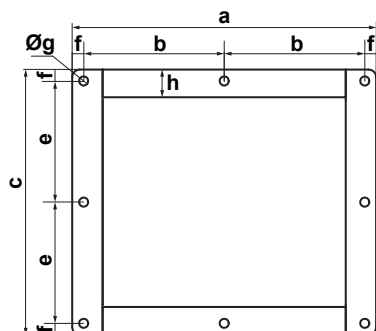

D...-TRON 6

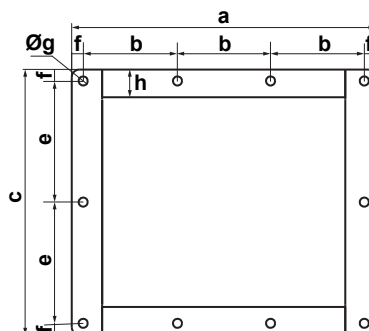

D...-TRON 7

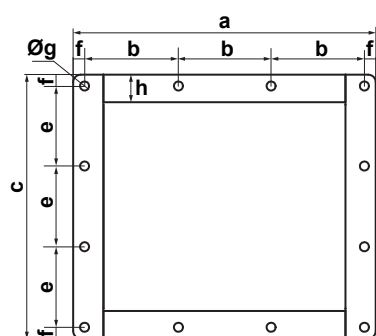

D...-TRON 8

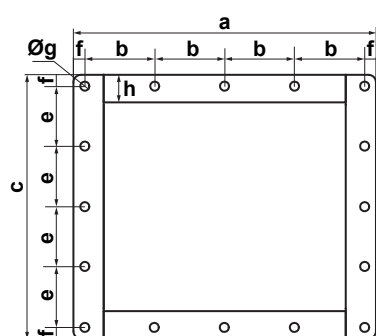

	a	b	c	d	e	f	Øg	h
D...-TRON 2	303	136,5	252	222	-	15	6x R12	40
D...-TRON 3	345	157,5	287	257	-	15	6x R12	40
D...-TRON 4	400	185	349	-	159,5	15	8x R12	40
D...-TRON 5	470	220	361	-	165,5	15	8x R12	40
D...-TRON 6	557	173	474	-	218	19	10x R14	43
D...-TRON 7	730	230,7	650	-	204	19	12x R14	43
D...-TRON 8	930	223	828	-	197,5	19	16x R14	40

Dimensions in mm

# OVERALL DIMENSIONS

## Gas train

### VCS Kromschöder

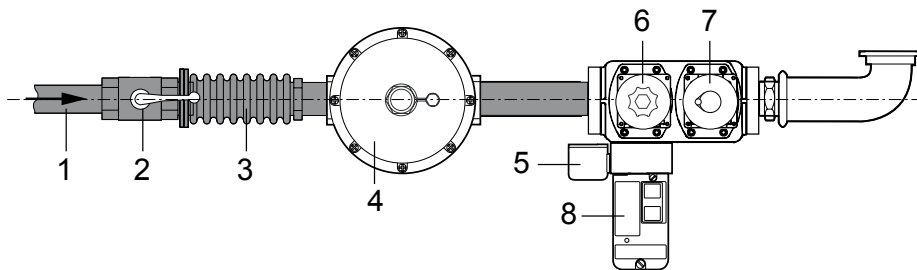

- 1 Main gas pipe
- 2 Ball valve
- 3 Antivibration coupling
- 4 Gas governor
- 5 Gas pressure switch
- 6 Safety gas valve
- 7 Working gas valve
- 8 Leakage control

### VCS...

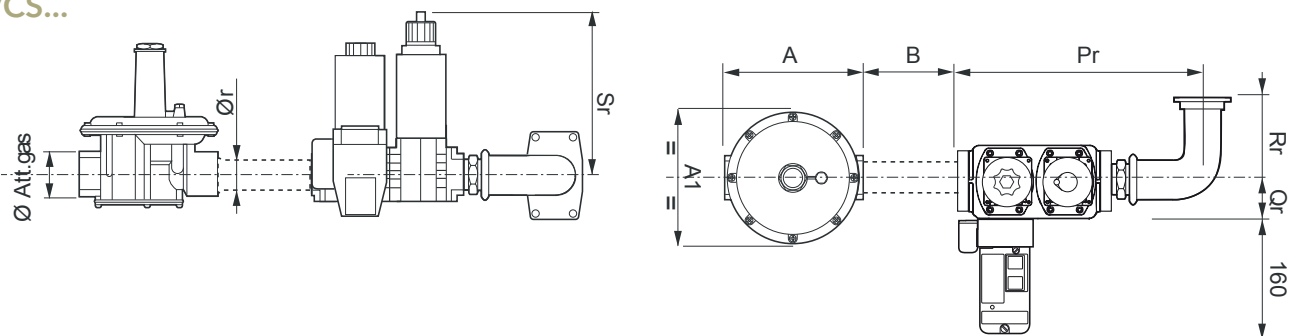

### D...-TRON 2

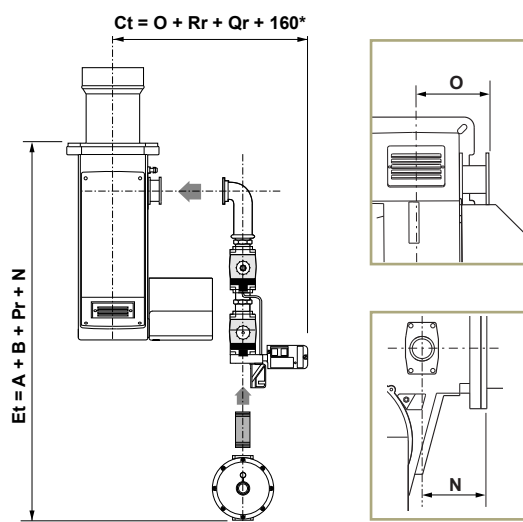

### D...-TRON 3...8

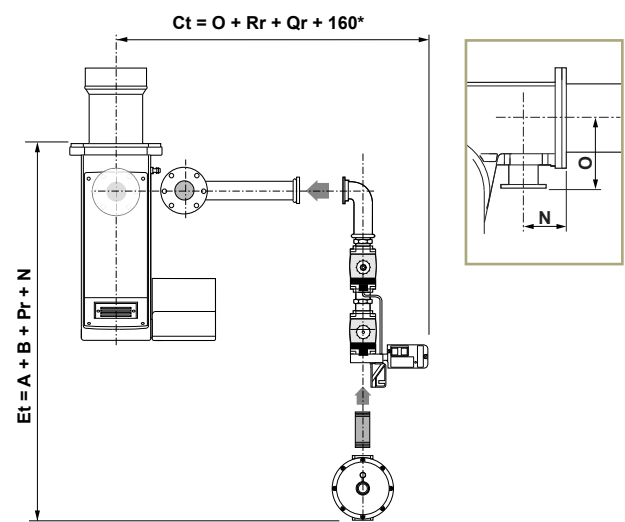

\*: kit VPS

### Note

In order to calculate the overall dimension of the burner complete with gas train (**Et** and **Ct**), you need to consider the dimensions of the gas train chosen according to the inlet gas pressure available in the following pages, and the connection pipe (if needed).

If the value **Et** is lower than **E**, consider **Et = E**.

# OVERALL DIMENSIONS

## Gas train

### VGD Siemens

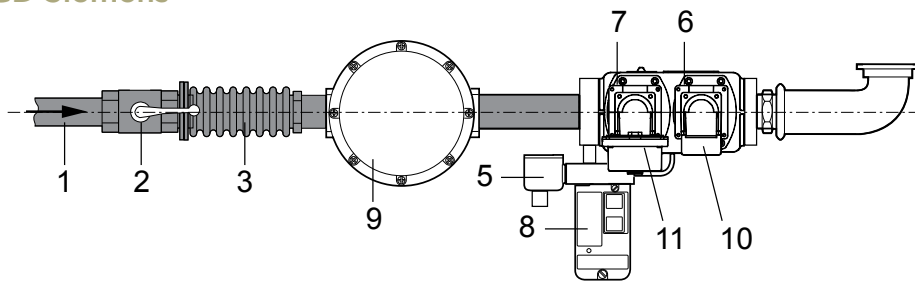

- 1 Main gas pipe
- 2 Ball valve
- 3 Antivibration coupling
- 4 Gas governor
- 5 Gas pressure switch
- 6 Safety gas valve
- 7 Working gas valve
- 8 Leakage control
- 9 Gas filter
- 10 Actuator
- 11 Actuator

### VGD20...

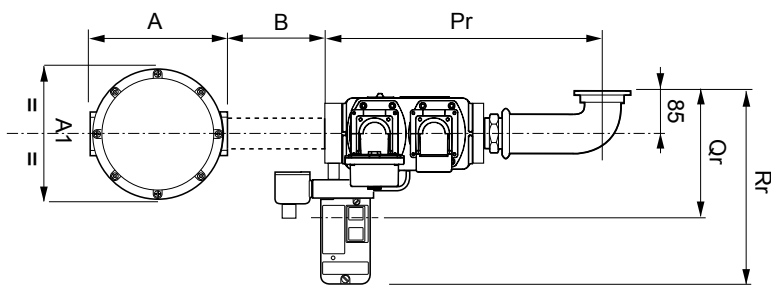

### VGD40...

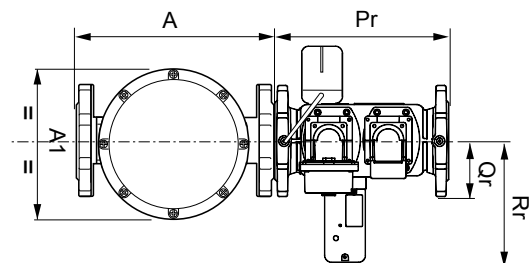

### D...-TRON 2

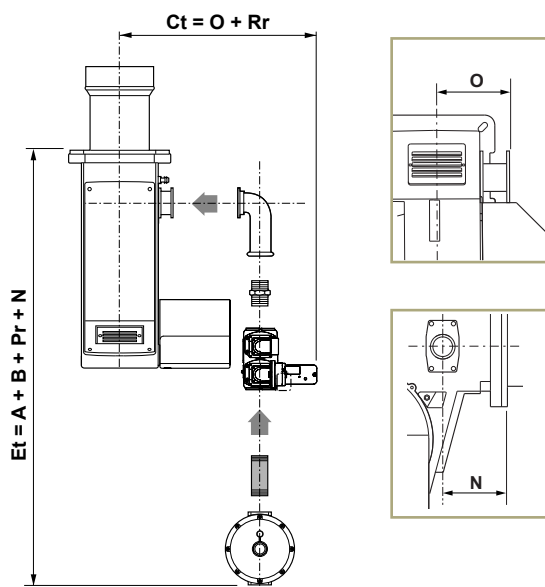

### D...-TRON 3...8

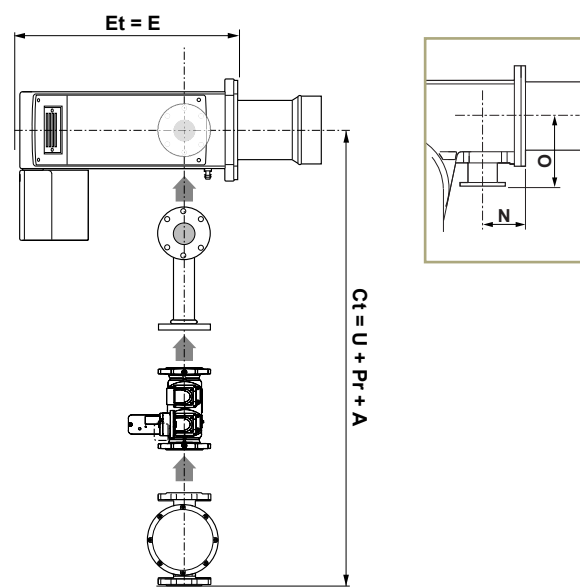

**Note**  
In order to calculate the overall dimension of the burner complete with gas train (**Et** and **Ct**), you need to consider the dimensions of the gas train chosen according to the inlet gas pressure available in the following pages, and the connection pipe (if needed).

# OVERALL DIMENSIONS

## Gas train connection pipe

### VCS Kromschroder

D...TRON 3-4

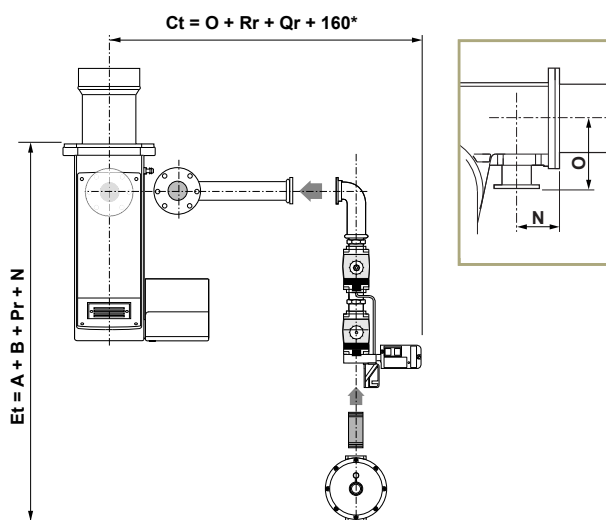
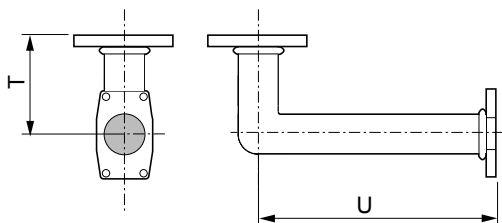

### VGD Siemens

VGD20...

D...TRON 3-4-5

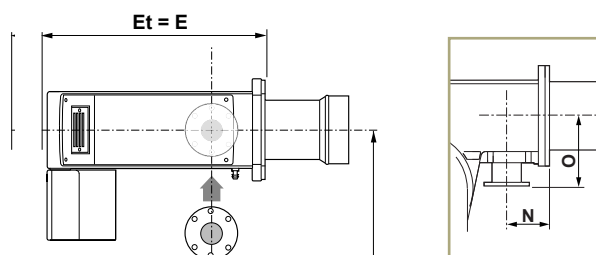
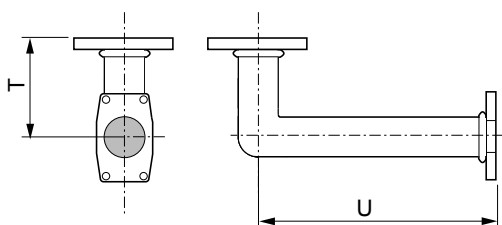

VGD40...

D...TRON 3...8

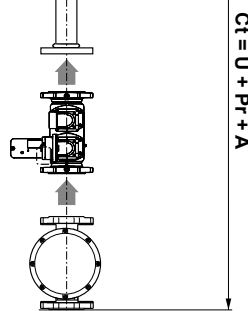
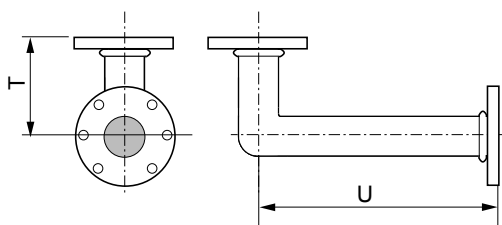



# GAS TRAINS

## Matching

	Gas train model	GTCP Dimension			GT Dimension					Gas governor & filter / Filter	FGDR - Filter		
		T	U	V	Pr	Qr	Rr	Sr	Ør		A	A1	B
D...TRON 2	VCS-125				310	65	155	215	1"	FGDR-RP25	146	131	>100
	VCS-240	-	-	-	310	82	155	240	1"1/2	FGDR-RP40	194	178	>100
	VCS-350				372	95	155	250	2"	FGDR-RP50	260	225	>100
D...TRON 3	VCS-240	85	400		310	82	155	240	1"1/2	FGDR-RP40	194	178	>100
	VCS-240	85	400	-	310	82	155	240	1"1/2	FGDR-RP50	260	225	>100
	VCS-350	85	400		372	95	155	250	2"	FGDR-RP50	260	225	>100
	VGD20.503	85	400	-	450	185	315	-	2"	Filter 2"	186	186	>100
	VGD40.065	104	560	104	290	97	211	-	DN65	Filter DN65	290	212	-
	VGD40.080	125	560	125	310	102	218	-	DN80	Filter DN80	320	240	-
D...TRON 4	VCS-350	85	588	-	372	95	155	250	2"	FGDR-RP50	260	225	>100
	VGD20.503	85	588	-	450	185	315	-	2"	Filter 2"	186	186	>100
	VGD40.065	104	560	104	290	97	211	-	DN65	Filter DN65	290	212	-
	VGD40.080	125	560	125	310	102	218	-	DN80	Filter DN80	320	240	-
	VGD40.100	125	560	255	350	113,5	229	-	DN100	Filter DN100	380	280	-
D...TRON 5	VGD20.503	85	588	-	450	185	315	-	2"	Filter 2"	186	186	>100
	VGD40.065	125	668	125	290	97	211	-	DN65	Filter DN65	290	212	-
	VGD40.080	125	668	125	310	102	218	-	DN80	Filter DN80	320	240	-
	VGD40.100	125	560	255	350	113,5	229	-	DN100	Filter DN100	380	280	-
	VGD40.125	125	718	164	400	127,5	243	-	DN125	Filter DN125	380	280	-
D...TRON 6 up to 9 MW	VGD40.065	202	820	108	290	97	211	-	DN65	Filter DN65	290	212	-
	VGD40.080	221	820	129	310	102	218	-	DN80	Filter DN80	320	240	-
	VGD40.100	165	820	165	350	113,5	229	-	DN100	Filter DN100	380	280	-
	VGD40.125	165	820	441	400	127,5	243	-	DN125	Filter DN125	380	280	-
D...TRON 6 up to 13 MW	VGD40.080	221	820	129	310	102	218	-	DN80	Filter DN80	320	240	-
	VGD40.100	165	820	165	350	113,5	229	-	DN100	Filter DN100	380	280	-
	VGD40.125	165	820	441	400	127,5	243	-	DN125	Filter DN125	380	280	-
D...TRON 7	VGD40.080	221	820	129	310	102	218	-	DN80	Filter DN80	320	240	-
	VGD40.100	165	820	165	350	113,5	229	-	DN100	Filter DN100	380	280	-
	VGD40.125	165	820	441	400	127,5	243	-	DN125	Filter DN125	380	280	-
D...TRON 8	VGD40.100	165	820	165	350	113,5	229	-	DN100	Filter DN100	380	280	-
	VGD40.125	165	820	441	400	127,5	243	-	DN125	Filter DN125	380	280	-

## SUBSIDIARIES:

### GERMANY

Dreieichstrasse, 10  
64546 Mörfelden  
Walldorf  
Tel. +49 06 105 968 192  
Fax +49 06 105 968 199

### NETHERLANDS

Meerpaalweg, 1  
1332 BB Almere  
P.O. box 30048  
1303 AA Almere  
Tel. +31 088 69 573 11  
Fax +31 088 69 573 90

### ENGLAND

Suite 3, The Crown House  
Blackpole East,  
Blackpole Road,  
Worcester WR3 8SG  
Tel. +44 01905 788010  
Fax +44 01905 788011

### FRANCE

14, rue du Saule Trapu  
Parc d'activité du Moulin  
91882 Massy  
Tel. +33 01 60 13 64 64  
Fax +33 01 60 13 64 65

### ITALY

Viale Roma, 41  
28100 Novara  
Tel. +39 0732 633 590  
Fax +39 0732 633 599

### RUSSIA

Eniseyskaya str. 1, bld 1,  
Office Center "LIRA" #415  
129344 Moscow  
Tel. +7 495 213 0300 #5700  
Fax +7 495 213 0302

### CHINA

17A2, V-Capital Bldg  
No. 333 Xian Xia Road  
200336 Shanghai  
Tel. +86 21 6039 8691  
Fax +86 21 6039 8620

Contact us to know more  
about our products and solutions

[contact@elco-burners.com](mailto:contact@elco-burners.com)